

BikeGuard



Despite many improvements in road safety, motorcyclists continue to be vulnerable and the roadside safety barrier which has saved many motorists lives, presents a hazard when impacted by motorcyclists. The rider often sustains serious injuries which generally prove fatal. Sharp bends and gradients with changes of direction are particularly hazardous.



BikeGuard, an award winning system, is fully tested to BS EN 1317 part 2 and fully approved by the Highways Agency for use on the UK trunk road network. ("HA Accepted EN1317 Compliant Road Restraint Systems" - Miscellaneous Section). BikeGuard is a high quality, lower steel beam that can be attached to "W" beam type safety barriers and Open Box Beam systems to improve the safety performance of these barriers when impacted by motorcyclists.



Used extensively throughout the UK, BikeGuard prevents motor cycles and particularly their riders from sliding under the barrier and becoming snagged on the barrier support posts. This considerably reduces the extent of motorcyclist injuries and is a product endorsed by both coroners and emergency services.



BikeGuard is manufactured in galvanised steel, and is fixed to the barrier with specially shaped brackets which attach to the rear of the barrier rail, allowing the BikeGuard to perform independently of the barrier during impact. The BikeGuard system utilises slotted holes and a hanging bracket to enable horizontal and vertical adjustment. The brackets are secured to the back of the barrier with purpose designed fixings to suit different barrier types. The system is available in 370mm deep X 2400mm & 4800mm (effective) long beams and a 300mm deep X 2400mm (effective) long beam.



BikeGuard is installed at numerous locations throughout the UK where accidents involving motorcyclists had previously resulted in death or serious injury. Since installing BikeGuard there have been accidents involving motorcyclists at these sites but no injuries have been reported. BikeGuard is available for installation now. Highway Care Limited will survey potential sites and offer design advice as part of our commitment to Highway Safety.

© Highway Care 17-04-2009

Highway Care Ltd

The Highlands • Detling Hill
Detling • Maidstone • Kent • ME14 3HT
Tel: +44 (0) 1622 734215 • Fax: +44 (0) 1622 735106
E-mail: info@highwaycare.co.uk • www.highwaycare.co.uk

Unit D • Wharton Court
Leominster • Herefordshire • HR6 0NX
Tel: +44 (0) 1568 610909 • Fax: +44 (0) 1568 620007
E-mail: enquiry@highwaycare.co.uk • www.highwaycare.co.uk



Highway Care

BikeGuard - Details

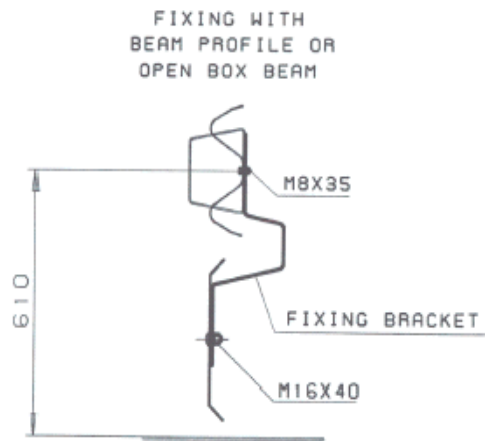
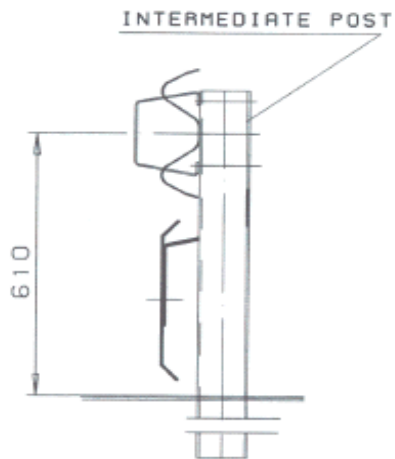
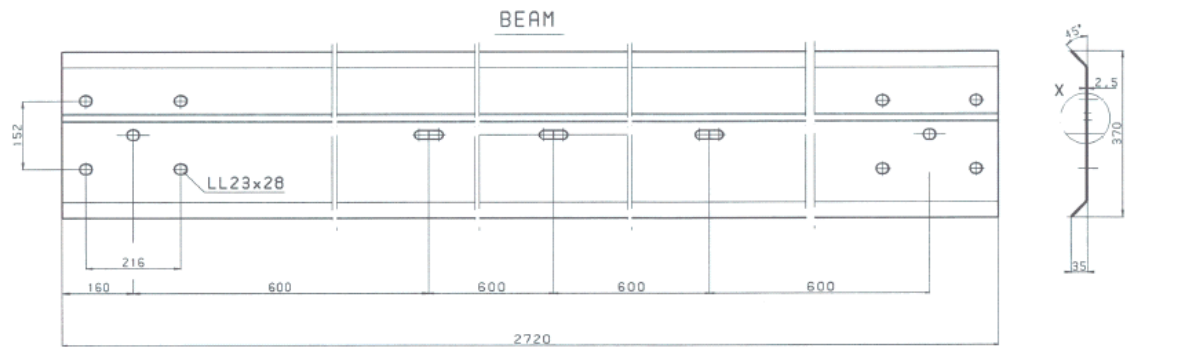
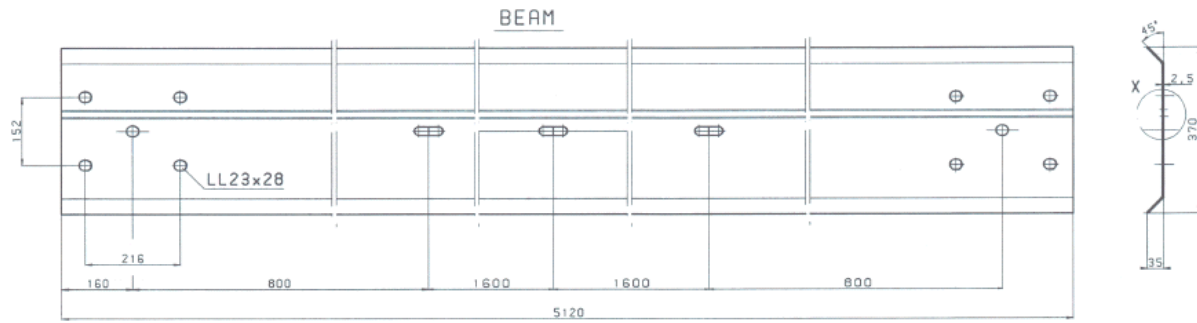
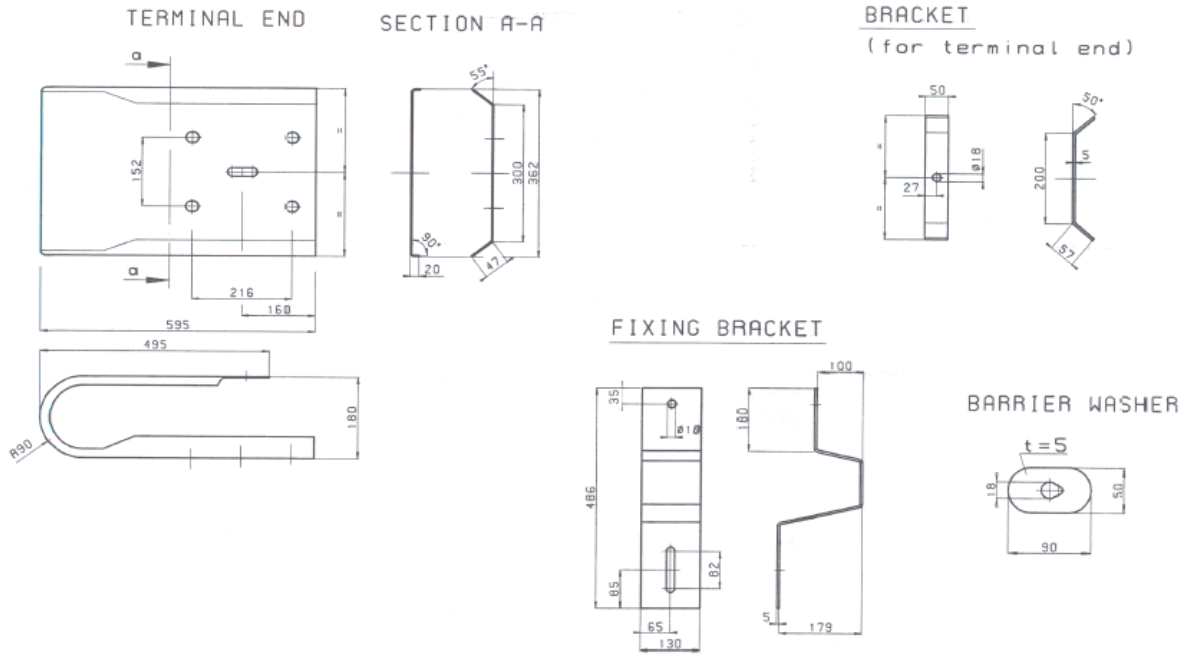

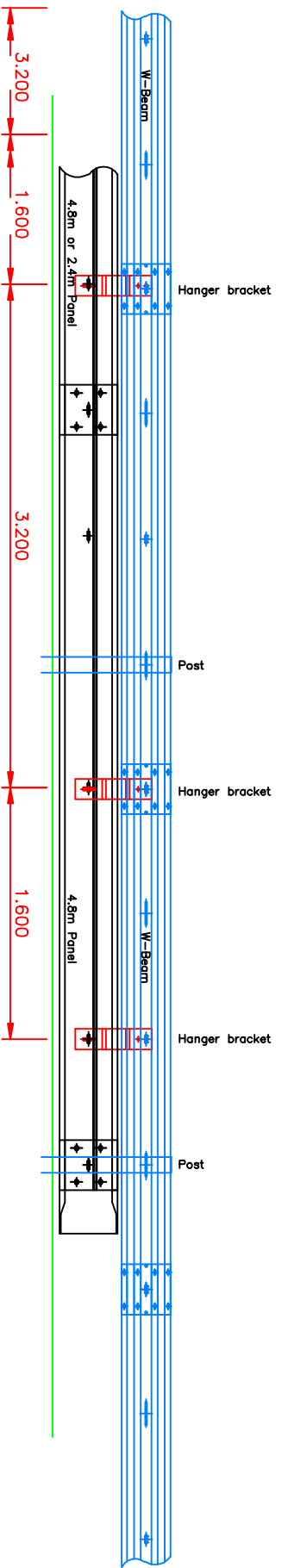

Bike-Guard on W-Beam
Ideal Starting Point for Assembly

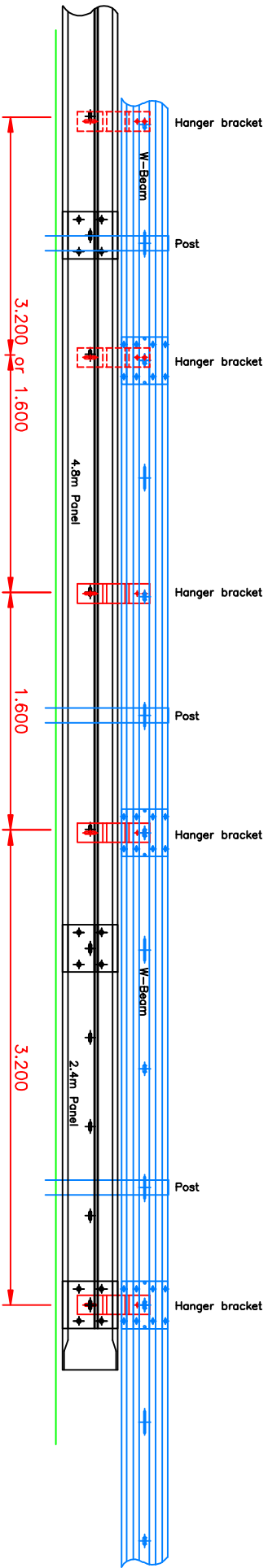

Bike-Guard on W-Beam
Alternative Starting Point for Assembly
(only OK if start with 2.4m, then 4.8m afterwards)

The Highlands Dunning Hill Dalriada Melrose Kent ME14 3HT Tel: +44 (0) 1622 736215 Fax: +44 (0) 1622 735108 www.highwaycare.co.uk		Highway Care		Rev Details		CHKD 		APPR 		Title BIKEGUARD Assembly on W-Beam		Drawn Checked Approved Scale at A3		Date Date Date Date		Revision 		Status 		

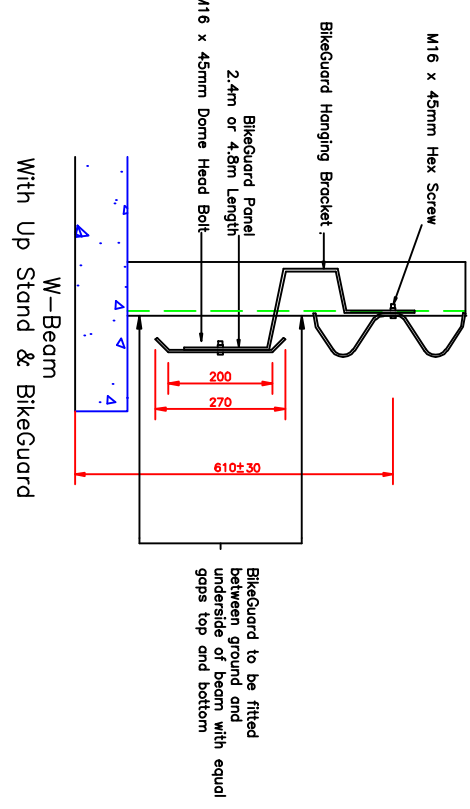
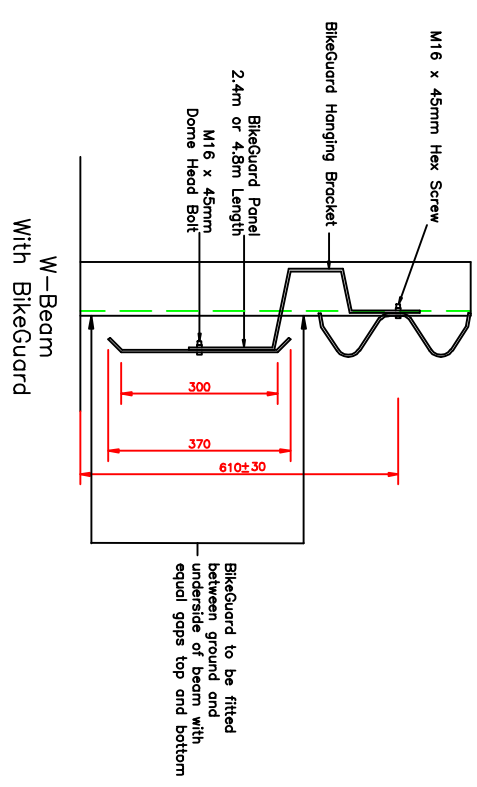
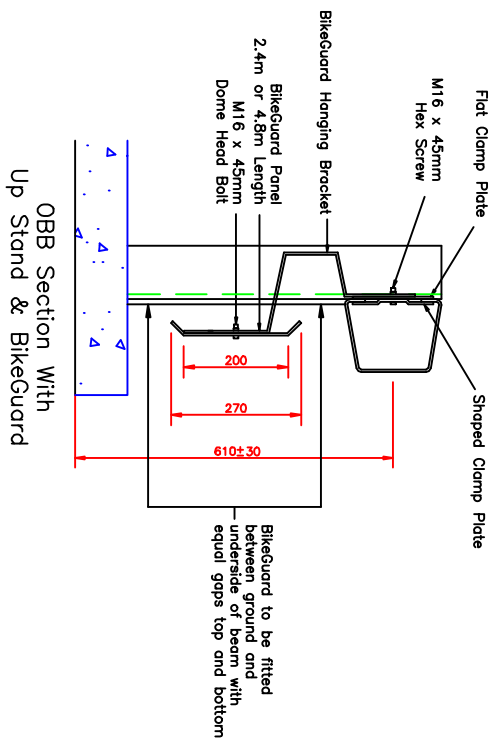
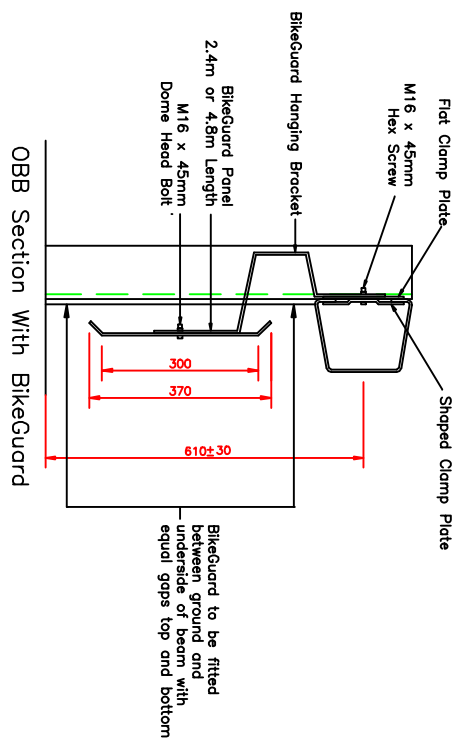

The Highlands
Dunfermline
Dumfries
Melrose
Kerridge
Kerridge
Tel: +44 (0) 1622 736215
Fax: +44 (0) 1622 735106
www.highwaycare.co.uk

Rev	Details	CHK'd	App'd
A		AB	AB
B	Fasteners amended	SM	AB

BikeGuard Profiles on OBB & W-Beam

Drawn	MH	Date
Checked	AB	160309
Approved	AB	160309
Scale at A3	N/A	
Revision		Status

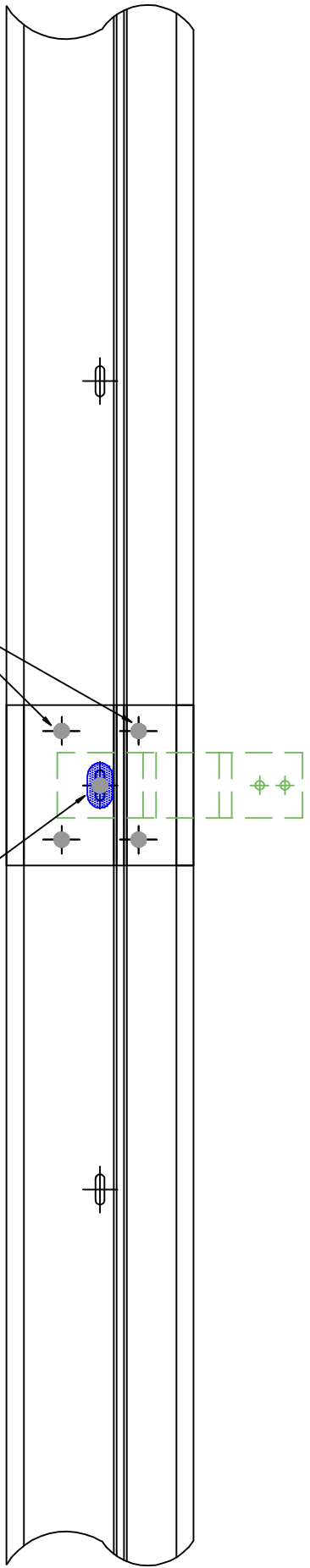

M16 x 45mm Dome Head Bolt & M16 Oval Washer

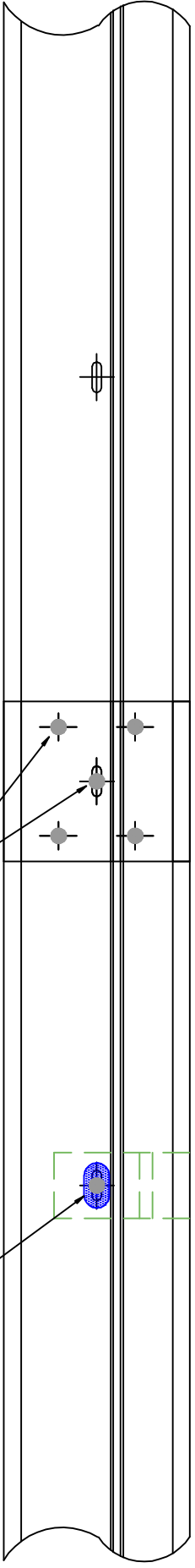

M16 x 45mm Dome Head Bolt & M16 Oval Washer



The Highlands
Dorling Hill
Dedding
Malden
Kent ME14 3HT
Tel: +44 (0) 1622 734215
Fax: +44 (0) 1622 735108
www.highwaycare.co.uk

Rev	Details	CHK'd	App'd	Tbse

BikeGuard Jointing

Drawn	SM	Date	26.03.09
Checked	AB	Date	26.03.09
Approved	AB	Date	26.03.09
Scale at A3	N/A		
Revision		Status	

BikeGuard - Picture Gallery



© Highway Care 17-04-2009

Highway Care Ltd

The Highlands • Detling Hill
 Detling • Maidstone • Kent • ME14 3HT
 Tel: +44 (0) 1622 734215 • Fax: +44 (0) 1622 735106
 E-mail: info@highwaycare.co.uk • www.highwaycare.co.uk

Unit D • Wharton Court
 Leominster • Herefordshire • HR6 0NX
 Tel: +44 (0) 1568 610909 • Fax: +44 (0) 1568 620007
 E-mail: enquiry@highwaycare.co.uk • www.highwaycare.co.uk



Highway Care