

# THE RISK OF FATALITY IN MOTORCYCLE CRASHES WITH ROADSIDE BARRIERS

Hampton C. Gabler

Virginia Tech  
United States

Paper Number 07-0474

## ABSTRACT

The objective of this study is to examine the issue of fatal motorcycle collisions with guardrail based on U.S. accident statistics. Motorcycle crashes were found to be the leading source of fatalities in guardrail crashes. In 2005 for the first time, motorcycle riders suffered more fatalities (224) than the passengers of cars (171) or any other single vehicle type involved in a guardrail collision. In terms of fatalities per registered vehicle, motorcycle riders are dramatically overrepresented in number of fatalities resulting from guardrail impacts. Motorcycles compose only 2% of the vehicle fleet, but account for 42% of all fatalities resulting from guardrail collisions. Motorcycle-guardrail crash fatalities are a growing problem. From 2000-2005, the number of car occupants who were fatally injured in guardrail collisions declined by 31% from 251 to 171 deaths. In contrast, the number of motorcyclists fatally-injured in guardrail crashes increased by 73% from 129 to 224 fatalities during the same time period. Over two-thirds of motorcycle riders who were fatally injured in a guardrail crash were wearing a helmet. Approximately, one in eight motorcyclists who struck a guardrail were fatally injured – a fatality risk over 80 times higher than for car occupants involved in a collision with a guardrail.

## INTRODUCTION

Motorcyclists are vulnerable highway users. Unlike passenger vehicle occupants, motorcycle riders have neither the protective structural cage nor the advanced restraints which are commonplace in cars and light trucks. Previous research has shown that motorcycle crashes into roadside barrier are particularly dangerous. In one of the earliest studies on this issue, Ouelett (1982) investigated the outcome of motorcycle-guardrail crashes drawn from a larger database of approximately 900 motorcycle crashes in the Los Angeles area (Hurt et al, 1981). He reported that motorcycle impacts with guardrail impacts have a much higher fatality risk than motorcycle crashes in general. Other researchers have also noted the increased risk of motorcycle collisions with

guardrails (Domham, 1987; Quincy et al, 1988, Gibson and Benetatos, 2000, and Berg et al, 2005). Because of an upsurge in motorcycle fatalities, the issue of motorcycle safety is receiving renewed attention. As shown in Figure 1, motorcycle registrations in the U.S. are growing at the rate of 7-8% per year. Unfortunately, fatal motorcycle crashes are growing at a comparable rate.

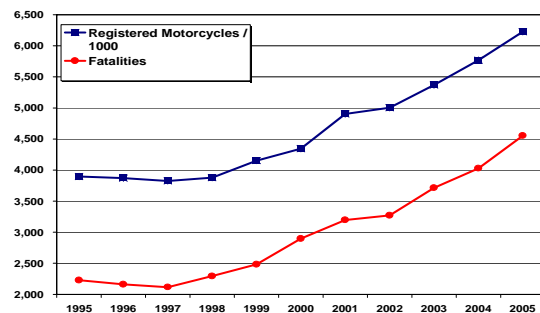


Figure 1. U.S. Motorcycle Registrations vs. Crash Fatalities (NHTSA, 2006)

## OBJECTIVE

Motivated by the growing U.S. motorcycle fleet and number of motorcyclist fatalities, the objective of this study is to examine one facet of this problem – the magnitude and characteristics of fatal motorcycle collisions with guardrail.

## APPROACH

This study was based on the analysis of the Fatality Analysis Reporting System (FARS) database and the National Automotive Sampling System (NASS) General Sampling System (GES). FARS, a comprehensive census of all traffic related fatalities in the U.S., was analyzed to determine guardrail crash fatality trends. GES was analyzed to determine the number of occupants who were exposed to guardrail crashes. The GES sample included both fatal and non-fatal crashes into guardrail. GES is a comprehensive database containing information on approximately 60,000 randomly sampled police reported accidents each year. Cases from GES are

assigned weights that can be used to estimate the number of similar accidents that may have taken place that year that were not sampled. Because GES is a sample of police reported accidents, NHTSA (2000) notes that GES estimates are subject to both sampling and non-sampling errors. In both FARS and GES, a guardrail collision was defined to be a crash in which the most harmful event was a collision with a guardrail.

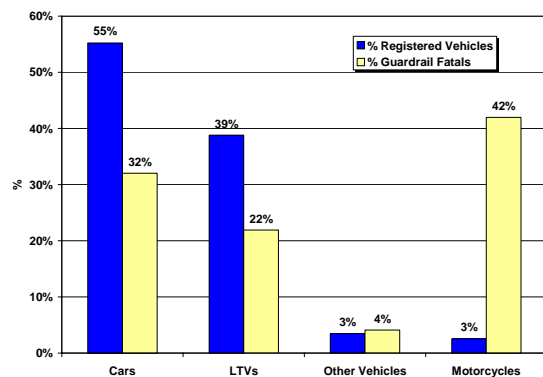
Prior to 2004, FARS aggregated guardrail length of need and guardrail end treatments into a single guardrail category. It was therefore not possible in FARS to identify which portion of the guardrail system was struck. For example, it was not possible to determine differential fatality risk in guardrail length of need versus guardrail end treatments. Beginning in 2004, FARS began to code guardrail 'face' separately from guardrail 'end'. However, because only two years from our 16 year dataset contains this distinction, both guardrail categories from FARS 2004-2005 data were aggregated into a single guardrail group.

## RESULTS

The analysis which follows investigates fatality risk for motorcycle collisions with two different types of roadside barrier: metal guardrail and concrete barriers.

### Fatality Risk in Guardrail Collisions

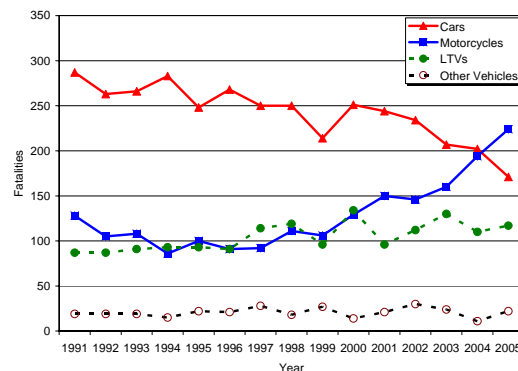
Figure 2 presents the distribution of fatalities by vehicle body type in collisions in which a guardrail impact was the most harmful event. The distribution of fatalities and vehicle registrations are for the 2005 calendar year (NHTSA, 2006).



**Figure 2. Guardrail Crash Fatalities vs. Registrations by Vehicle Body Type (FARS 2005; NHTSA, 2006)**

In absolute numbers, motorcycle riders now account for more fatalities than the passengers of any other vehicle type involved in a guardrail collision. As shown in Figure 2, motorcycle riders accounted for 42% of all fatalities resulting for a guardrail collision in 2005. Following motorcycle riders were car occupants with 32% of all fatalities in this crash mode. This was a particularly surprising finding as cars compose over half of the vehicle fleet (55%) while motorcycles comprise only 3% of the registered vehicles. The occupants of light trucks and vans (LTVs), a category which includes pickup trucks, sport utility vehicles, minivans, and full sized vans, trailed car occupants with 22% of the guardrail crash fatalities and 39% of the registered vehicles in 2005. In terms of fatalities per registered vehicle, motorcycle riders are dramatically overrepresented in number of fatalities resulting from guardrail impacts.

As shown in Figure 3, the problem of motorcycle fatalities in guardrail collisions is a growing problem. From 2000-2005, the number of car occupants who were fatally injured in guardrail collisions declined by 31% from 251 deaths in 2001 to 171 deaths in 2005. In contrast, the number of fatally-injured motorcyclists increased by 73% from 129 to 224 fatalities during the same time period. In 2000, fatalities from motorcycle-guardrail collisions exceeded the number of deaths from LTV-guardrail collisions. In 2005, motorcyclist rider fatalities (224) resulting from guardrail collisions surpassed car fatalities (171) for the first time.



**Figure 3. Motorcycle Rider Fatalities Exceeded Car Occupant Fatalities in Guardrail Crashes for the first time in 2005 (FARS 1991-2005)**

### Probability of Fatality in Guardrail Collisions

To analyze the risk of fatal motorcycle crashes with guardrail, the probability of fatality in this collision mode was computed as a function of vehicle body type. For this study, fatality risk was defined as shown below:

$$FatalityRisk = \frac{NumberOfFatalities}{NumberOfExposedOccupants}$$

The number of persons who were fatally injured in guardrail collisions was obtained from FARS 2000-2005. The number of occupants who were exposed to guardrail collisions was obtained from GES 2000-2005. In both databases, a guardrail collision was defined to be a crash in which the most harmful event was a collision with a guardrail. Table 1 presents the average annual number of fatalities and exposed occupants during this five year time period.

**Table 1. Fatality Risk in Guardrail Collisions by Body Type from 2000-2005 (GES, FARS)**

Vehicle Type	Number of Occupants exposed to Guardrail Collisions	Number of Fatalities from Guardrail Collisions	Fatality Risk	Relative Fatality Risk compared with Car Occupants
Cars	855,900	1,309	0.15%	1.0
LTV	260,200	699	0.27%	1.8
Motorcycles	8,100	1,003	12.4%	81.1

Approximately one of every eight motorcyclists who struck a guardrail was fatally injured. This fatality risk is substantially higher than incurred by either car or LTV occupants. Only one to two of every 1000 car occupants were fatally injured in a crash with a guardrail. Another way to consider this risk is by comparison to the relative risk to which car occupants are exposed in guardrail crashes. In Table 1, a relative fatality risk was computed for each vehicle body type category as shown below:

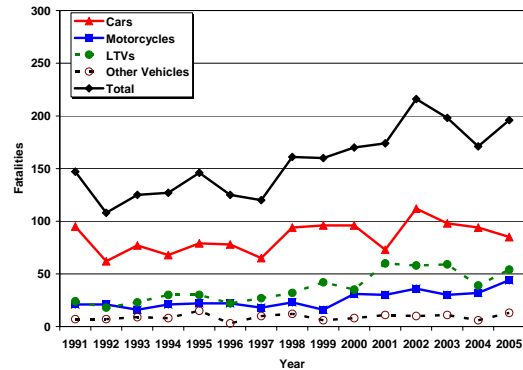
$$Relative\ Fatality\ Risk = \frac{FatalityRiskforSubjectVehicleType}{FatalityRiskforCarOccupants}$$

In a guardrail collision, motorcycle riders have a risk of fatality over 80 times greater than car occupants. LTV occupants have 1.8 times the risk of fatality of a car occupant. In a guardrail collision, there is little to protect a motorcyclist from injury. The vehicle structure and occupant restraints which could protect a car or LTV occupant are simply not present in current motorcycle designs.

### Fatality Risk in Collisions with Concrete Barriers

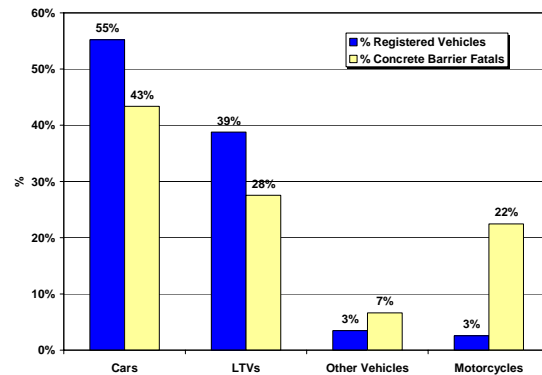
Figure 4 presents the number of fatalities in collisions with concrete barriers as a function of vehicle type. Unlike guardrail crashes, most fatalities in concrete barrier collisions are suffered by car occupants, followed by the occupants of LTVs. Motorcyclists suffer the third highest number of fatalities in

concrete barrier collisions. The fact that motorcyclist collisions are the leading cause of fatalities in guardrail collisions, but only the third leading cause of fatalities in concrete barrier collisions, may provide an important insight into the mechanism of injury in these crashes. Either concrete barriers pose a markedly lower fatality risk for motorcyclists than do guardrails or motorcyclists are proportionally less likely to collide with concrete barriers than guardrails.



**Figure 4. Fatalities in Concrete Barrier Crashes 1991-2005 (FARS 1991-2005)**

Figure 5 presents the distribution of fatalities by vehicle body type in collisions in which an impact with a concrete barrier was the most harmful event. The distribution of fatalities and vehicle registrations are for the 2005 calendar year (NHTSA, 2006).



**Figure 5. Concrete Barrier Crash Fatalities vs. Registrations by Vehicle Body Type (FARS 2005; NHTSA, 2006)**

As witnessed earlier, motorcyclists are overrepresented in fatality risk. Motorcycles accounted for only 3% of registered vehicles in the U.S. in 2005, but incurred 22% of all fatalities in concrete barrier collisions. Comparing motorcycle-guardrail and motorcycle-concrete barrier fatalities per registered vehicle, guardrail collisions pose a greater risk for motorcyclists than concrete barriers.

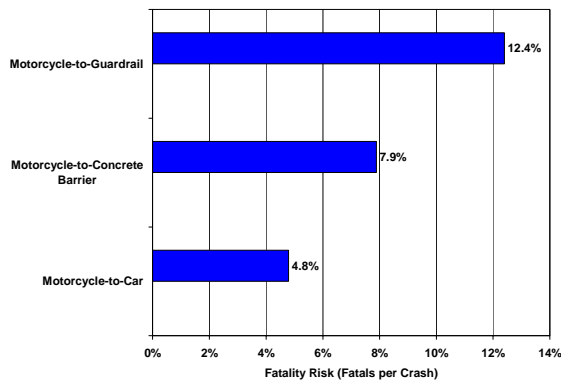
**Table 2. Fatality Risk in Concrete Barrier Collisions by Body Type from 2000-2005**

Vehicle Type	Number of Occupants exposed to Guardrail Collisions	Number of Fatalities from Guardrail Collisions	Fatality Risk	Relative Fatality Risk compared with Car Occupants
Cars	526,260	558	0.11%	1.0
LTV	148,321	305	0.19%	1.9
Motorcycles	2,574	203	7.9%	74.4

Approximately one of every twelve motorcyclists who struck a guardrail was fatally injured. This fatality risk is lower than the risk for motorcyclists which strike guardrail, and substantially higher than incurred by either car or LTV occupants. As for guardrail collisions, a relative fatality risk was computed for each vehicle body type category. In a guardrail collision, motorcycle riders have a risk of fatality over 70 times greater than car occupants.

**Comparison of Motorcyclist Fatality Risk by Object Struck**

As shown in Figure 6, guardrail collisions pose a substantially greater risk for motorcyclists than do collisions with either concrete barrier or cars. The fatality risk in motorcycle-guardrail collisions is 12%. The fatality risk in motorcycle-concrete barrier collisions is 8%. The fatality risk for motorcycle-car collision is 4.8% - approximately only one-third risk of a motorcycle-guardrail collision.

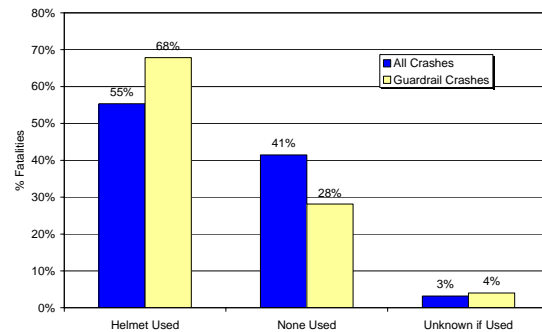


**Figure 6. Fatality Risk by Object Struck (FARS-2005) in 2005**

**Effect of Helmet Use**

One method of protecting motorcyclist in crashes is the use of a helmet. Figure 7 shows that in 2005 over

two-thirds of all motorcycle riders who were fatally injured in guardrail crashes were wearing their helmets. This helmet use rate is slightly higher than the helmet use rate for motorcyclists in all fatal crashes (55%). Unfortunately, motorcycle helmets do not appear to completely protect motorcycle riders against fatality in guardrail crashes. Presumably, helmets reduce the incidence of head injury in guardrail crashes. However, even if the national motorcycle helmet usage rate was 100%, Figure 7 shows that motorcycle collisions with guardrail would still result in fatalities.



**Figure 7. Distribution of Motorcycle Fatalities by Helmet Use in 2005**

**Implications**

Motorcyclists are vulnerable highway users, particularly in guardrail crashes. Because of a lack of protective equipment, motorcycle riders are exposed to a much greater risk of death in a crash than are passenger vehicle occupants. This study has shown that in terms of fatalities per registered vehicle motorcycle riders are over-represented in fatalities in guardrail crashes. Motorcycle rider fatalities exceeded car occupant fatalities in guardrail crashes for the first time in 2005.

Crash testing of roadside barriers under NCHRP 350 (Ross et al, 1993) has led to a remarkably low number of fatalities for passenger vehicle occupants involved in guardrail collisions. Motorcycle riders however have not enjoyed the same benefit. Even if a future guardrail system were implemented which eliminated all passenger vehicle-guardrail fatalities, over 40% of all guardrail fatalities in 2005 would remain unless the motorcycle-to-guardrail collision problem is remediated. A possible solution are motorcycle-friendly guardrail systems, developed and tested by groups in both Europe and Australia, which have the potential to mitigate the consequences of a motorcycle-guardrail collision. Berg et al (2005) provides examples of these systems.

Motorcycle-guardrail crash fatalities are an unmet and growing safety problem in the U.S. Motorcycle-based countermeasures being developed by motorcycle manufacturers may provide part of the solution to this problem, but are likely to be of limited success as demonstrated by the failure of helmets to protect completely against fatality. In conjunction with these motorcycle-based countermeasures, there is a critical need to adopt improved barrier designs to protect these vulnerable road users.

## CONCLUSIONS

This paper has examined the risk of fatality in motorcycle collisions with guardrails. The conclusions of this study are as follows:

1. Motorcycle crashes are the leading source of fatalities in guardrail crashes in the U.S. In 2005 for the first time, motorcycle riders suffered more fatalities (224) than the passengers of cars (171) or any other single vehicle type involved in a guardrail collision.
2. In terms of fatalities per registered vehicle, motorcycle riders are dramatically over-represented in number of fatalities resulting from guardrail impacts. In 2005, motorcycles composed only 3% of the vehicle fleet, but accounted for 42% of all fatalities resulting from guardrail collisions, and 22% of the fatalities from concrete barrier collisions.
3. Over two-thirds of motorcycle riders who were fatally injured in a guardrail crash were wearing a helmet.
4. Motorcycle-guardrail crash fatalities are a growing problem. From 2000-2005, the number of car occupants who were fatally injured in guardrail collisions declined by 31% from 251 to 171 deaths. In contrast, the number of fatally-injured motorcyclists increased by 73% from 129 to 224 fatalities during the same time period.
5. Approximately, one in eight motorcyclists who struck a guardrail were fatally injured – a fatality risk over 80 times higher than for car occupants involved in a collision with a guardrail.
6. Guardrail collisions pose a substantially greater risk for motorcyclists than do concrete barrier collisions. The fatality risk in motorcycle-guardrail collisions is 12%. The fatality risk in motorcycle-concrete barrier collisions is 8%.
7. Motorcycle-roadside barrier crash fatalities are an unmet and growing safety problem in the U.S. There is a critical need for the development and / or implementation of new safety programs,

advanced barrier designs, and enhanced vehicle-based countermeasures to protect motorcyclists in collisions with guardrails.

## REFERENCES

1. Ouellet, J.V., "Environmental Hazards in Motorcycle Accidents", Proceedings of the 26<sup>th</sup> Annual Meeting of the American Association for Automotive Medicine, Ottawa, Ontario, Canada, 1982.
2. Hurt, H., Ouellet, J.V., and Thom, D., *Motorcycle Accident Cause Factors and Identification of Countermeasures*, Volume I, DOT Technical Report, Contract No. DOT HS-5-01160, Washington DC, 1981
3. Domham, M. "Crash Barriers and Passive Safety for Motorcyclists", Proceedings of the Stapp Car Crash Conference, SAE Paper No. 870242, 1987.
4. Quincy, R., Vulin, D., and Mounier, B., "Motorcycle Impacts with Guardrails", Transportation Research Circular, No. 341, pp. 23-28, 1988.
5. Gibson, T. and Benetatos, E., *Motorcycles and Crash Barriers*, NSW Motorcycle Council Report, 2000.
6. Berg, F.A., Rucker, P., Gartner, M., Konig, J., Grzebieta, R., and Zou, R., *Motorcycle Impacts into Roadside Barriers – Real World Accident Studies, Crash Tests, and Simulations Carried Out in Germany and Australia*, Proceedings of the Nineteenth International Conference on Enhanced Safety of Vehicles", Washington, DC, 2005.
7. Ross, H.E., Sicking, D.L., Zimmer, R.A., and J.D. Michie. *Recommended Procedures for the Safety Performance Evaluation of Highway Features*. NCHRP Report 350, TRB, National Research Council, Washington, D.C., 1993.
8. National Highway Traffic Administration (NHTSA). *Traffic Safety Facts 2005: A Compilation of Motor Vehicle Crash Data from the Fatality Analysis Reporting System and the General Estimates System*, U.S. Department of Transportation Report, DOT HS 810 631, 2006.
9. National Highway Traffic Safety Administration (NHTSA). *National Automotive Sampling System (NASS) General Estimates System (GES) Analytical Users Manual 1988-1999*. U.S. Department of Transportation, 2000.

## SIM PROJECT: A WAY FOR PTW INTEGRATED SAFETY

**Federico Galliano**

**Mario Donato Santucci**

Piaggio & C. SpA

Italy

**Oliver Hoffmann**

Continental Teves AG&Co. oHG

Germany

**Begoña Pérez-Magallón**

CIDAUT

Spain

**Massimo Guiggiani**

University of Pisa

Department of Mechanical, Nuclear and Production Engineering

Italy

Paper Number 07-0080

### ABSTRACT

The paper will describe the features and characteristics of the project SIM (Safety In Motion). SIM Project is aimed at carrying out R&D activities addressing in-depth studies of a suitable and comprehensive safety strategy for powered-two-wheel (PTW) vehicles, in order to avoid road accidents and/or mitigate their consequences. Main objectives of SIM are:

- to identify a suitable safety strategy for PTWs;
- to enhance preventive and active safety acting on electronic vehicle management and improving Human-Machine-Interaction (HMI);
- to focus on integral passive safety devices;

An integrated approach to the complex concept of motorcycle safety shall establish a matrix relationship between the three main factors or pillars for safety (PTW, rider and infrastructure) and the different aspects related to accident dynamics, from before-precipitating event to crash event (dealing with preventive, active and passive safety). The research will be based on the analysis of motorcycle accident databases from MAIDS, GIDAS and DEKRA. According to that, SIM project focuses on the **vehicle safety aspects**, including the **human-machine-interaction**.

Main results expected are:

- development of electronic active devices (e.g. enhanced anti-lock braking system, traction control and brake-by-wire) for powered two-wheelers;
- development of a passive safety algorithm to activate passive safety devices;
- adaptation of protective inflatable devices located on the rider (garment) and on the vehicle (for lower limbs protection);
- implementation of innovative HMI

On-road and laboratory tests, based on the most relevant accident scenarios, will be conducted in order to evaluate the effectiveness of the safety

system devices (e.g. mitigation of injuries via inflatable devices, probability of avoiding accident, etc...) fitted on an integrated concept vehicle.

Innovation aspects are mainly an integrated approach to the issue and the introduction of new safety technologies in PTW field.

### PROJECT OBJECTIVES

#### Project context

Over 6000 among 40,000 fatalities on European roads in 2001 are related to the Powered-Two-Wheelers-vehicles (PTW's). Compared to the overall number of victims on the roads, this figure represents 15% of this dreadful aspect of our society. The European Commission has launched the 3rd European Road Safety Action Plan with the ambitious goal of reducing the fatalities by 50% in 2010. By 2025, the number of persons killed or severely injured on the road shall be reduced by 75%. To this goal, the motorcycle Industry have a role to play in improving the safety features of its products, while keeping their characteristics of versatility.

What are powered-two-wheel-vehicles (PTW's)?

The following is the definition stated in Directive 2002/24/EC that regulates all technical prescriptions for the type-approval of these vehicles:

- (a) mopeds, i.e. two-wheel vehicles (category L1e) or three-wheel vehicles (category L2e) with a maximum design speed of not more than 45 km/h and characterised by:
  - (i) in the case of the two-wheel type, an engine whose:
    - cylinder capacity does not exceed 50 cm<sup>3</sup> in the case of the internal combustion type, or

- maximum continuous rated power is no more than 4 kW in the case of an electric motor;
- (ii) in the case of the three-wheel type, an engine whose:
  - cylinder capacity does not exceed 50 cm<sup>3</sup> if of the spark (positive) ignition type, or
  - maximum net power output does not exceed 4 kW in the case of other internal combustion engines, or
  - maximum continuous rated power does not exceed 4 kW in the case of an electric motor;
- (b) motorcycles, i.e. two-wheel vehicles without a sidecar (category L3e) or with a sidecar (category L4e), fitted with an engine having a cylinder capacity of more than 50 cm<sup>3</sup> if of the internal combustion type and/or having a maximum design speed of more than 45 km/h;
- (c) motor tricycles, i.e. vehicles with three symmetrically arranged wheels (category L5e) fitted with an engine having a cylinder capacity of more than 50 cm<sup>3</sup> if of the internal combustion type and/or a maximum design speed of more than 45 km/h.

Therefore, when we talk of PTW's, we also have to take into account vehicles with **3 wheels**.

The Motorcycle Industry in Europe, united in ACEM (European Motorcycle Manufacturers' Association) has been active since 1994 in the matter of motorcycle safety, contributing to the establishment of technical European regulations with the highest level of requirements in terms of safety and proposing, launching and managing the first European in-depth study on motorcycle accident (MAIDS, Motorcycle Accident In-Depth Study), which established methodological benchmarking for any similar study.

MAIDS focused on the aetiology of the accidents, identifying the main causative factors distributed in human, mechanical and environmental aspects. The analysis of the causative factors were based on the MAIDS database that contains 921 accidents studied in detail. In order to identify the risk factors, thus identifying the real areas where to intervene for a significant reduction of accidents and casualties, another database of 923 controls (see MAIDS Report, ACEM, 2004, <http://www.acembike.org>) has been established.

The findings published in the report show several important topics, which have been used by ACEM to define a Motorcycle Safety Plan for Action, aiming at contributing effectively to the European goal of reducing by 50% casualties on the road. The Plan for Action can be downloaded from ACEM website ([www.acembike.org](http://www.acembike.org)).

Main result of MAIDS is to have identified the causative factors to accident causation from an overall scene point-of-view.

The main findings of MAIDS, as indicated in the MAIDS Report, could be split in aspects related to accident causation and consequences They are synthetically reported below.

**Accident causation** – Accident statistical analysis about risk factors, collision dynamics and other aspects shown:

- the main primary contributing factors were “human behaviour” related ( 37.1% for PTW rider and 50.4% for the Opponent Vehicle (OV) driver);
- in 10.6% of all cases, PTW rider inattention was present and contributed to accident causation;
- 3.7% of cases involved a PTW tyre problem and 1.2% a brake problem;
- in 36.6% of all cases, the primary contributing factor was a **perception failure** on the part of the OV driver;
- 27.7% of PTW riders and 62.9% of OV drivers made a **traffic-scan error** which contributed to the accident;
- 32.2% of PTW riders and 40.6% of OV drivers engaged in **faulty traffic strategies** which contributed to the accident.
- considering multi-vehicle accidents (about 85% of overall cases) it also has been pointed out that 73% of all PTW riders attempted some emergency manoeuvre but:
  - in 30% of cases there was a **loss of control** (braking, swerving, etc...);
  - in 32.2% there was **no time available** for PTW rider to complete a collision avoidance manoeuvre.

**Accident consequences** - Rider injuries, type of rider protection and other post-crash events are considered. It is pointed up:

a total of 3644 injuries were reported. Most injuries were reported to be minor lacerations, abrasions or contusions;

- lower extremity injuries made up 31.8% of all injuries;
- upper extremity injuries made up 23.9% of all injuries;
- head injuries accounted for 18.7% of all reported injuries;
- most upper and lower extremity injuries occurred as a result of impacts with the OV or the roadway;
- in 69% of cases, helmets were found to be effective at preventing or reducing the severity of head injury;

- there were cases of helmets coming off the riders head due to improper fastening of the retention system or helmet damage during the crash sequence.

**A plan for action** – MAIDS results refuted some commonplaces about PTW risk factors indicating that:

- engine displacement does not represent a risk factor in accident involvement;
- speed is not a contributing factor, especially in multi-vehicle accidents (70% of impact speed less than 50 km/h).

Motorcycle safety is a complex concept involving several aspects (preventive, active and passive safety) and several factors (mechanical, human and infrastructural). A matrix approach (See Figure 1) could help to describe all the different areas in which improvement is possible:

SIM	ACTIVE	PREVENT.	PASSIVE	POST-CRASH
MOTORBIKE	Suspensions, Brakes, ABS, ESP...	HMI, conspicuity, ...	Limbs protection, kinematics, algorithm, ...	e-Call
MOTORCYCLIST HELMETS/ CLOTHING	Training and Education	HMI, comfort, strap fasten, info exchange, conspicuity ...	Helmets & Clothing performance ...	
INFRASTRUCTURE	Maintenance, audits, ...	e-Safety	Performance when a motorcyclist impacts	Maintenance, repair, ...

**Figure 1. the safety matrix**

On the basis of MAIDS results and the matrix approach, SIM Project aims at evaluating the effectiveness of an innovative vehicle, equipped with state of the art car-derived safety technologies, in real-life accident scenarios.

Safety In Motion (SIM) project aims to cover some of the cells of the “*safety matrix*” focusing on the vehicle safety aspects, including the human-machine-interaction. Other cells are and will be covered by running projects (like APROSYS SP4, SAFESPOT, WATCH-OVER, PISa).

The most relevant element in SIM is the ambitious objective of developing a comprehensive safety strategy for motorcycles, structuring cooperation with existing research projects in order to cover adequately all the different fields of application.

SIM itself is focussing on **vehicle-based** safety applications.

On preventive safety, SIM is implementing and evaluating Human-Machine Interaction systems, based on ADAS technology.

On active safety, SIM is implementing and evaluating dynamic stability control system based on active (electronic) suspension systems, traction control, enhanced anti-lock braking system.

Finally, SIM is implementing and evaluating an integrated protection system to mitigate the consequences of accident. This system will integrate inflatable devices applied on the vehicle with inflatable device worn by the rider (and passenger).

### Scientific and Technological Objectives

Last decade is characterized by a relevant increase in EU countries in the number of registration of Powered Two wheelers. This is due to the spread of an utilitarian use of PTW’s. New riders choose this transport mode mainly to cover more quickly home-office trips, avoiding queues and parking issues.

This new category of riders is not necessarily interested in riding characteristics neither is fully aware of risks related to improper use.

Focusing on vehicle peculiarities it should be stressed that riding a PTW is a **complex task** and every rider should keep in mind these points:

- PTW rider’s are one of the most vulnerable road users;
- PTW balance conditions can be obtained only in dynamic way;
- path change is more complex than a 4-wheelers (by actions involving the whole rider-plus-vehicle system).

On the other side complexity of on-board instrumentation is rising and there is an amount of information to be managed (perception, comprehension and decision tasks are involved), so workload (and risk of distraction) increases and the risk level of having an accident grows.

SIM project would focus on **active** and **passive safety** aspects mainly from a **PTW-point-of-view**. **Preventive safety** will also be covered, especially in considering **Human-Vehicle interaction**.

**Active safety** – On active safety, SIM is implementing and evaluating a dynamic stability control system based on active (electronic) suspension systems, traction control, enhanced anti-lock braking system. This is because the MAIDS Project has highlighted that loss of control is one of the main problems in motorcycle accidents.

The objective of active safety devices on-board is to improve substantially all elements contributing to vehicle stability and balance. This is required in all riding conditions.

In order to achieve this objective, SIM wants to improve all vehicle subsystems designed to keep wheels rolling with no slither and with optimal grip in the most critical motion conditions:

- acceleration and braking;
- cornering and steering.



Further to that, a new generation Anti-lock Braking System is considered, with a better behaviour in cornering and steering and adaptable on wet road surface conditions.

Electronically controlled suspensions for the optimisation of load-shift in acceleration and deceleration will be implemented, together with a traction control system.

**Passive safety** – SIM is implementing and evaluating an integrated protection system to mitigate the consequences of accident. This system will integrate inflatable devices applied on the vehicle with inflatable device worn by the rider (and passenger).

Even if main aim of SIM is to avoid accidents, passive safety systems are essential to mitigate consequence in case of inevitable precipitating events.

In order to achieve that, SIM is developing and validating a tailor-made integrated passive system for PTW's.

Algorithms for the activation of the passive system will be adapted and sensors and actuators will be implemented on-board.

Protective devices, located on the rider (e.g. inflatable garment) and on the vehicle (for limbs protection) will be adapted.

**Preventive safety** – Based on reasons above described, SIM will implement and evaluate Human-Machine Interaction systems, based on ADAS (Advanced Driver Assistance System) technology.

Special focus will be devoted to the innovative dashboard that will be designed to help the rider in getting the correct and adequate information with no workload in excess. The objective is the development of a dashboard providing information on the basis of hierarchical logic that provides the rider with information instantaneously important. The prototype will be compared in effectiveness (reduction of the workload, reduction in reaction time) with an equivalent traditional-design dashboard, available from high-end vehicles.

Helmet will be an integral part of the system, helping in the exchange of information and in control operation, through a radio link. This allows information flow from vehicle to rider and voice-operated controls in opposite way to inquire on-board information system (e.g. phone activation, menu scrolling, and so on...).

In this context, an analysis of existing wireless technologies (e.g. Radio Frequency, Ultra Wide Band, Bluetooth, etc.) will be carried over, as well as an evaluation of technical-economic feasibility.

Also "augmented reality" aspects will be considered, only at theoretical level, as well as non-conventional controls (haptic controls) and non-conventional information display.

The study and development of the above-described devices is based on cognitive ergonomics, bearing in mind the *dual-task paradigm* for the evaluation of the proposed solution effectiveness.

Preventive, active and passive safety aspects will be integrated into the same prototype in order to develop and validate a comprehensive safety strategy for PTW's.

## Project Approach

SIM's aim consists in the development and realisation of a **new concept vehicle** that intrinsically enhances PTW safety, merging the **handling** of classic PTW and the **stability** of passenger cars, by developing and implementing **active, preventive** and **passive safety** devices.

The project plan deals with the following:

**Strategic vision** – the Safety Strategy in Motorcycles will be appraised by means of a first identification of the most important (in terms of frequency and severity) accident scenarios that involve this type of vehicles to focus on the worst cases. We will be able to identify problems and needs through the analysis of those scenarios: the project starts from **accident analysis** and main findings performed in the MAIDS project (1999-2004) that is the most relevant research project on motorcycle accidents and the only in-depth analysis at European level.

Nowadays PTW offers an effective solution to problems related to urban transport and leisure. Its diffusion is desirable and useful in terms of quality of life, environmental impact and fuel consumption. So, the flexibility of use and the easiness in handling, especially developed on recent models, attract new customers, unused to the risks of motorcycles: running a motorcycle is a complex task, involving a level of risk of having an accident that cannot be underestimated.

However, the development and realisation of a new concept vehicle that intrinsically enhance PTW safety, merging the handling of classic PTW and the stability of passenger cars, will positively affect, in the SIM consortium opinion, this share of PTW accidents reducing drastically its negative consequences in terms of injuries and fatalities.

**Technical targets** – SIM will focus on **Active, Preventive and Passive Safety** systems on-board of the motorcycle deploying innovative technologies in order to bring the development of an enhanced-safety vehicle, contributing to the fatalities reduction on European roads.

This will be managed by studying and implementing Powered Two Wheelers (PTW) dynamic systems for what concerns active and preventive safety, while passive safety will focus on rider protection systems fitted both on the

vehicle and on those rider protection systems worn by the motorcyclists but operated by devices fitted on the vehicle.

The state of the art in passenger car will be implemented in SIM's new concept, studying an "ad hoc" design for PTW's, especially for **active safety** technologies.

The aim is the development of an Integral Dynamic Stability Control that integrates and manages single electronically controlled subsystems (ABS system, traction control and suspension systems) in order to optimise vehicle control and stability performances, acting on grip, load transfer, avoiding slither and so on. Although SIM will do all the effort to reduce the event of a crash, it cannot simply dismiss it.

SIM will include also the implementation of innovative **passive safety** devices on the concept vehicle such as airbag, inflatable garments and lower limb protective devices, taking into account potential benefit of airbag technologies in selected scenarios, considering problems related to the wide range of possible outcomes of a two-wheeler accident. The injury mechanisms involved differ very considerably from those found in car accidents. SIM will carefully consider the critical importance for the successful development of any safety device of the study of all impact configurations, not only those likely to give rise to the sort of injuries under study, but also all other configurations, so to ensure that there is no increase in the risk of other types of injuries.

The use of innovative technologies and systems will open new opportunities in the development of Human-Machine Interaction (HMI) for a **preventive safety** issue, which is a relevant concern, and almost undeveloped in motorcycles and scooters.

SIM will study and develop an HMI design, aiming mainly to minimize workload and distraction imposed by In-vehicle Information Systems (navigation systems, vehicle-to-vehicle communication systems, phone systems). Maximisation of the safety benefits of new Advanced Driver Assistance Systems will be considered, by establishing links with other running projects focused on Intelligent Transportation Systems (ITS), with specific development on motorcycles: this communication flow between the rider and the motorcycle systems will be established through the helmet.

The use of ITS applications which can influence the behavior of a motorcycle - for example by applying the brakes or regulating the fuel management system - should always be optional, and only considered when it has been demonstrated that they will not destabilize a motorcycle in a range of conditions and circumstances. Because of PTW's dynamics, some ITS applications will not be able to be adapted to motorcycles, or may not be cost effective. Traffic management applications of

ITS should be developed to include motorcycles and could usefully be adapted to give them priority over other vehicles.

**Prototype development** – All the devices and systems studied and implemented in the first phases of the project, will be integrated, as it is intended to generate a prototype as **Integral Safety Solution** that will be further tested to prove its structural integrity and to ensure its capability of contributing to the European Commission goal of reducing fatalities in the European roads;

An **integrated safety approach** is followed and addressed in two ways:

- (a) In order to give a contribution to the spread of PTW, the aim of SIM consists in making PTW safer, by following the philosophy of "maximum control with minimum effort". SIM will provide an "easy" vehicle in every sense, letting the pilot pay attention only to the traffic and the way. SIM expects to intervene and provide solutions from *before the precipitating event* (i.e. the time from which the crash is inevitable) until *after the crash*, mitigating its consequence.
- (b) All above is related to on-vehicle technologies and devices. However, the consortium endeavours to establish links with all on-going, past and present projects related to motorcycle safety in order to guarantee a 360° outlook for improving motorcycle safety records.

Not only the tests will be used as **dissemination** mean but also intermediate and final results will be disseminated in conferences, workshops, publications, sharing of information with the main stakeholders involved in the field and the creation of a web site.

### Overall description of the project plan

The work in SIM project will be divided in six Workpackages (WP). A brief description of their contents is described in the table below (See Table 1):

**Table 1.**  
**Project structure and description**

WP#	Title and short description
WP1	<b>Project management</b> To manage and coordinate consortium activities.
WP2	<b>Safety Strategy</b> To identify main parameters affecting PTW accident dynamics in main accident scenarios and establish a "safety strategy" for motorcyclist and links with other R&D projects about road safety.

<b>WP3</b>	<b>PTW Active safety</b> To focus on an improved motorbike concept design in order to enhance the motorcyclist's safety through the improvement of active safety devices (suspensions, brakes, traction control). Further, preventive safety will be considered in terms of HMI and improved comfort.
<b>WP4</b>	<b>PTW Passive safety</b> To develop effective passive safety systems for motorcycles that act in case of accident, mitigating the consequences of the crash event.
<b>WP5</b>	<b>Integral Safety solution</b> To demonstrate the feasibility of integrated safety concepts applied on motorcycle through definition of test bed. Technical tests will be run and evaluation of cost/benefit ratio in terms of potential reduction of accidents and mitigation of consequences will be performed.
<b>WP6</b>	<b>Dissemination and Exploitation</b> To organize and harmonize the spreading of information and results generated with regard to integrated safety on motorcycles; To evaluate guidelines for standardisation activities and market acceptance of the innovative devices analysed and implemented during the project.

## Methodology approach

The activities of the project are carried out by six workpackages:

**WP1 Project Management** – The first work package will take in charge the overall coordination of the project, in order to ensure the management of the activities regarding Financial and Technical Administration of the Project, establishing an Executive Committee and including an activity of Quality Assurance.

**WP2 Safety Strategy** – WP2 will start at the beginning of the project and last 6 months with the goal of identifying accident scenarios and to evaluate technical solutions and potential improvements effectiveness. Moreover, activities that will be carried out in this work package will be devoted to links and collaboration with other R&D projects focusing on motorcyclists safety. DEKRA will be the leader of the work package with the participation of PIAGGIO across all the

activities and the support of CIDAUT in the accident analysis.

**WP3 PTW Active Safety** – The work package has an overall duration of 14 months and deals with the identification of the most promising technical solutions related to active and preventive safety. Main work package activities will consist in the definition of active and preventive safety, vehicle dynamic systems, electronic control of active systems implementation, HMI and comfort, active and preventive safety systems integration. CRF will be the leader of this project, being involved in the design and development of the specific preventive safety applications and of the related HMI Systems, with the participation of several partners for the definition of the concept (PIAGGIO), for the vehicle system definition (UNIPI, CONTI), for the electronic system (CIDAUT, CONTI, OHLINS) for the HMI and comfort (PIAGGIO, NZI) and for the integration (PIAGGIO, CRF, CONTI).

**WP4 PTW Passive Safety** – The work will begin focusing on the development of highly effective passive safety systems for motorcycles that act in case of crash event. The main actors in the field of passive safety, during a period of 14 months and led by CIDAUT, will work each one on their specific field of knowledge: vehicle, helmet, electronic control unit and airbag. DALPHIM and UNIPI will provide their contribution in the definition of the concept, rider protection system and system integration; CONTI will take part in the definition of the electronic control system and provide sensors and actuators. PIAGGIO will cooperate in the definition of the concept.

**WP5 Integral Safety Solution** – This work package will establish the feasibility of integrated safety concepts applied on motorcycle, defining technical tests to be run, technical assessment of the overall integrated system and the HMI strategies, evaluating in terms of potential reduction of accident events and potential mitigation of their consequences. Within a total period of 22 months, PIAGGIO will lead this part of the project, with the support of UNIPI in Integrated System Specification, of CRF for the integration of active and preventive safety systems on-board, of CIDAUT for the integration of passive safety systems, and of DEKRA for the activity of testing and evaluation.

**WP6 Dissemination and exploitation** – It is responsible for correct and widespread dissemination of information and results generated with regard to integrated safety on motorcycles. CTUP will be the leader of this work package, with the participation of PIAGGIO in both of the tasks.

University of West Bohemia – New Technologies Research Centre (UWB)	European research institute with high competencies in CFD simulation and impact dynamics analysis
---	---

## THE CONSORTIUM AND PROJECT RESOURCES

### Consortium Overview

**Table 2.**  
**List of participants**

Organisation legal name (Short name)	Experiences
PIAGGIO & C. SpA (PIAGGIO)	World motorcycle manufacturer and project coordinator
Foundation for the Research and Development in Transport and Energy (CIDAUT)	Centre of excellence in the Transport and Energy sectors with high specialization in Technological R&D, Diffusion, Transfer and Training
Continental Teves AG&Co. oHG (CONTI)	World's leading manufacturer of brake and stability control systems and major electronic supplier
Centro Ricerche Fiat ScpA (CRF)	European car manufacturer
Technical University of Prague (CTUP)	European research institute with competencies in design, organisation and control of transportation processes
DALPHIMETAL ESPAÑA S.A. (DALPHIM)	European airbag supplier
DEKRA e.V. (DEKRA)	International service provider for Accident Research and Crash Test
NZI HELMETS (NZI)	Small OEM focused in helmets design and production
OHLINS RACING AB (OHLINS)	Leading manufacturer of suspension for cars and motorcycles
Savatech d.o.o., Industrial Rubber Products and Tyres (SAVA)	Rubber compounds and tyres manufacturer for motorcycles and industrial vehicles
University of Pisa (UNIPI)	European research institute with expertise in vehicle dynamics analysis and design

### A complementary and self-consistent Consortium

The participants in SIM represent a well-balanced consortium, including representatives of all relevant actors involved in the development and integration of systems for road safety as well as representatives of the scientific and academic world.

Within the consortium, Piaggio, as leading motorcycle manufacturer, guarantees the integration of the different systems for active, preventive and passive safety on a motorcycle concept for innovative and advanced rider safety, also providing the specifications for the actual implementation of the systems; Continental Teves and Ohlins, respectively leaders in braking systems and semi-active suspensions, provide expertise and scientific knowledge on the specific devices, while Sava contributes with its competencies in design, development and testing of motorcycle tyres.

CIDAUT, Centro Ricerche Fiat and Dekra support the consortium with their methodological expertise and technological knowledge. The three institutes will have specific tasks to perform in the project:

- CIDAUT supports the Coordinator in his tasks having an operational and administrative role. Its main contribution to the project is the leadership of WP4 “Passive Safety”. In this WP, passive safety systems located on the rider and fitted on the vehicle will be investigated as well as the correct performance of the integral system.
- CRF main contribution to the project is the overall management of WP3 “Active Safety” as well as the active participation in WP2 “Safety Strategy” for the definition of the application scenarios that will become the reference scenarios for the system implementation to improve the safety of PTW.
- Dekra ensures the leadership of WP2 “Safety Strategy”, with the development of the knowledge foundation of the project. The identification of safety scenarios will provide the consortium with the elements of investigation related to the safety technologies to be implemented on motorcycles.

The Universities of Pisa, Prague and West Bohemia provide the scientific background as well as the expertise in modelisation of dynamic systems and the study of biomechanics for the rider protection systems. Furthermore, Prague and West Bohemia

are responsible for the implementation of the dissemination activity, in cooperation with the coordinator.

Dalhimetal provides the necessary expertise in the development and implementation of passive safety devices, while NZI contributes its expertise in helmets both in terms of passive safety improvement and, more important, the study of ergonomics (physical and cognitive) to improve preventive and active safety.

This unique blend of expertise and knowledge guarantees consistency in the implementation of the project, robust results and real exploitation of the findings.

# BASIC RESEARCH FOR A NEW AIRBAG SYSTEM FOR MOTORCYCLE

**Shoji Kanbe**

**Motoaki Deguchi**

**Yousei Hannya**

YAMAHA MOTOR CO., LTD.

Japan

Paper Number 07-0095

## ABSTRACT

Computer simulation of motorcycle crashworthiness was introduced in the development of a new airbag system. We chose MADYMO and PAM-SAFE as the basic software for the simulation. The new airbag system has several features suited to the special needs of motorcycles. Tests have shown that this air bag system is promising, but there are remaining technical issues that need to be resolved before it can be put to practical use.

## INTRODUCTION

Yamaha Motor Company has long worked to improve maneuverability and braking performance from the perspective of active safety. Recently, through participation in the Advanced Safety Vehicle (ASV) project promoted by the Ministry of Land, Infrastructure and Transport, Yamaha has also been looking at practical application of advanced active safety systems using information technology (IT). In addition to active safety, it is obviously important to study passive safety in collisions. Passive safety systems in automobiles already play an important role in reducing the number of traffic fatalities, and there is an increasing need for development of passive safety systems for motorcycles.

As announced in ASV-2 (Phase 2 Activities, 1996-2000), Yamaha has continued research on the practical application of airbags as a device to reduce rider's injuries in collisions (Figure 1). The airbag announced in ASV-2 exhibited a substantial effect on reducing the rider injury in frontal and similar collisions. However, a number of areas that needed improvement came to light. To overcome these problems and expand this effect, we are developing new motorcycle collision simulation technology and analyzing collision phenomena in computer

simulations, while also collecting data from crash tests with actual motorcycles. Based on these results, we set a goal of improving the effect of the airbag system by restraining the rider's body to the motorcycle in the initial phase of collisions.

This article introduces motorcycle crash simulation technology that is essential in the development of our airbags. Compared with automobile collisions, motorcycle collisions have specific problems such as the diversity of collision configurations that need to be investigated and the larger motions of motorcycle riders than automobile occupants during collisions. In the following we describe, with the introduction of case examples, how Yamaha approaches these problems. Then, using these simulations, we introduce the new airbag system now being studied.



**Figure 1. ASV-2 Airbag.**

## CRASH SIMULATION TECHNOLOGY

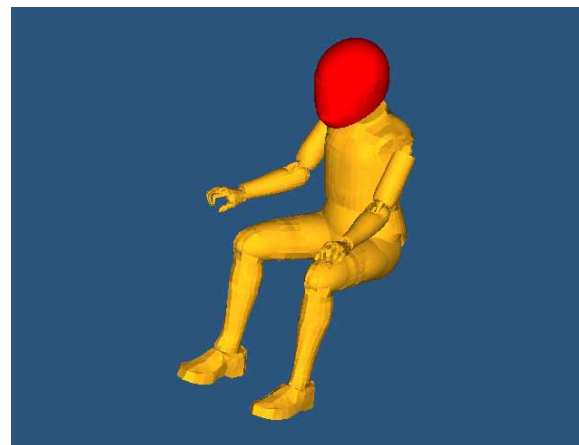
In developing vehicles and devices to reduce the rider injury in motorcycle collisions, experimental evaluation with actual motorcycles is essential. However, a huge number of factors need to be considered in collision phenomena, including vehicle speed and direction at the time of the collision, shape of the opposing vehicle, and location of impact. It is

not practical to cover all these factors in experiments, and the method of reproducing collisions on a computer through numerical simulation is useful as a means to supplement experiments. We have adopted two simulation methods in our simulations: MADYMO, multi-body dynamics-based software, and PAM-SAFE, crash analysis software based on the finite element method. Simulations using the finite element method generally require much greater amounts of modeling data than does multi-body dynamics analysis, and much time is needed for calculations. Conversely, high computational accuracy can be expected because of the detail of the model. With multi-body dynamics analysis, on the other hand, calculation time is short but it has the characteristic of being difficult to assure computational accuracy. Motorcycle crash simulations have a greater variety of configurations than do automobile simulations, and are characterized by the very long event time that needs to be considered. In motorcycle collisions with automobiles, considering primary impact (in which the rider dummy hits the opposing vehicle), 0.5 sec from the moment the motorcycle crashes into the automobile is required in ISO13232, which stipulates research evaluation methods for motorcycle rider protective devices. Considering also the entire impact sequence (which includes up to dummy to ground contact), usually 1 sec or more (at most 3 sec) needs to be analyzed after the initial impact between the motorcycle and automobile. We aimed to develop a simple but highly precise simulation method for the present research by adopting MADYMO as the base simulation method, and partially incorporating results of high computational accuracy from PAM-SAFE into the MADYMO model.

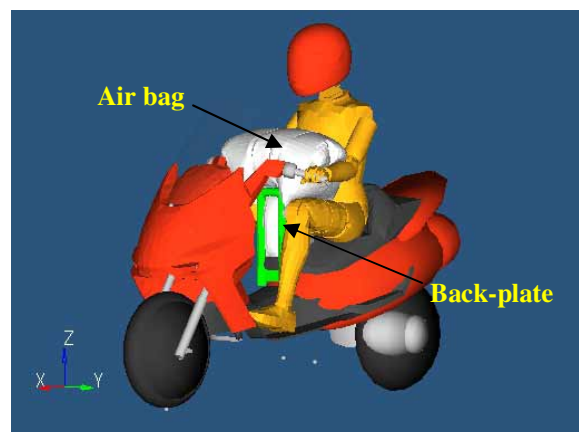
**MADYMO simulation**

As mentioned above, MADYO is multi-body dynamics analysis software in which the simulation model generally consists of rigid bodies, connecting joints, and the surfaces that show the shape of the object. At the same time that the surface shows the model shape, it is also attached to the rigid body to calculate the reaction force in contact. Simulations of motorcycle-automobile collisions

require a motorcycle model, rider dummy model, and automobile model. The process of creating these models was reported in ESV2003 (1) and ESV2005 (2). In those reports, the HYBRID-III standing model was used for the rider dummy model, but later the MATD model (dummy model specified in ISO13232) was introduced in the research. Figure 2 shows the MATD model as well as the helmet model that is also recommended in ISO13232. These models are multi-body models with facet surfaces (FE mesh-like surfaces), and are now available in the MADYMO dummy database. These facet surfaces were partly replaced by ellipsoidal surfaces to resolve some problems related to airbag contact, although they reproduce the dummy’s outer skin faithfully.



**Figure 2. MATD model.**



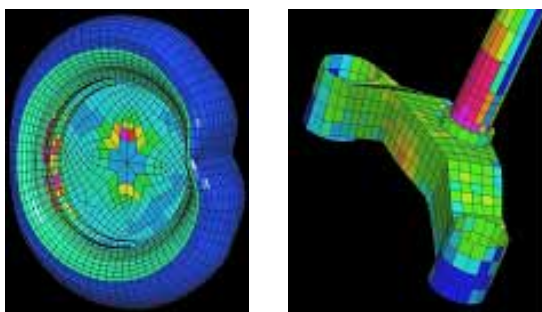
**Figure 3. Airbag model (MADYMO).**

In the present research an FE airbag model was created and added as a device to reduce the rider injury (Figure 3). However, the folding process is

greatly simplified in this model, and the model does not consider gas flow. For this reason, the shape of the airbag in the initial phase of deployment may not be accurately reproduced. In order to improve the dummy motion, a few temporary and imaginary contacts were added to the model by analyzing the dummy motion in the initial phase of airbag deployment.

**PAM-SAFE simulation**

PAM-SAFE is collision analysis software used worldwide that is based on the finite element method. As stated above, at YAMAHA the role of crash analysis based on the finite element method is to supplement analysis based on MADYMO, because of the special circumstances of motorcycle crash analysis. Therefore, the PAM-SAFE model is used mainly with a focus on analyses thought to contribute to raising the accuracy of MADYMO models. A crash model of a motorcycle front tire can be given as a specific example (Figure 4).



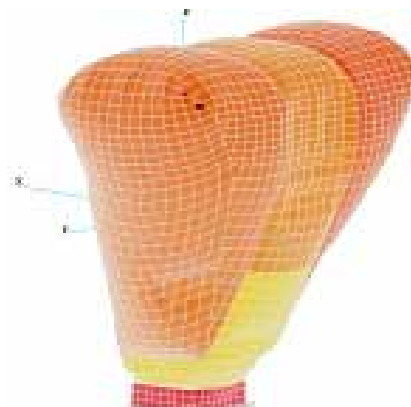
**Figure 4. Front tire and fork model.**

Unlike automobile collisions, in most motorcycle collisions the front tire collides with the opposing vehicle. As a result, the nonlinear deformation of the front wheel and tire and its contact reaction force influence the later motion of the motorcycle itself. For this reason, the model was constructed with the relatively detailed finite element model to obtain an accurate reaction force.

The root of the front fork also sustains large plastic deformation in collisions, and the nonlinearity in material strength should be considered (Figure 4). Therefore, this part is modeled and analyzed with the finite element method.

Next, calculations of deployment of the airbag (which is divided into compartments) from a folded

shape need to consider the detailed contact phenomena with the seat around the airbag. A PAM-SAFE model using detailed finite elements is suited to such analysis (Figure 5).



**Figure 5. Airbag model (PAM-SAFE).**

**AIRBAG DEVELOPMENT**

As stated above, the ASV-2 airbag was shown to have an effect to reduce the rider injury in certain collision configurations. Our aim is to give it this effect in a wider range of collision configurations. To achieve this, we are attempting not so much to prevent collisions of each part of the rider's body (mainly head and chest) with the opposing vehicle or motorcycle body, but to decelerate the rider's body itself. For this purpose, the airbag is positioned to remain as close as possible in contact with the rider. Also, to support the rider a member (called a back plate) to receive the force sustained by the airbag is used (Figure 3).

This prevents the rider from deviating greatly from the center of the airbag even in oblique collisions, and we can therefore expect an improved effect. In addition, the rider is decelerated by the airbag, so even in cases when the rider is thrown from the motorcycle, deceleration caused by the airbag is expected to reduce the injury suffered when the rider collides with the road or a roadside structure.



## Airbag

The function demanded of the airbag under study is to decelerate the rider's body itself. For this reason the airbag is close to the rider's center of gravity, shaped to act on the chest and lumbar area, and smaller than the ASV-2 airbag. However, it has sufficient front-to-back thickness to prevent injury to the rider's chest and abdominal area. Another characteristic of the airbag is that it has two internal dividing walls, separating the airbag into three chambers (Figure 6).

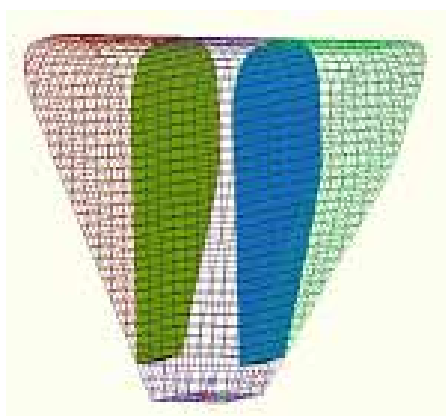


Figure 6. 3 chamber airbag.

The reason for dividing the airbag into chambers like this is so that it will rapidly pull up the back plate as described below. The center chamber is connected to the inflator. In deployment of the airbag, gas flows into the center chamber first, and the pressure rises quickly since the volume is small. The center chamber is therefore the first to rise quickly, and as it rises it pulls up the back plate. Gas flows into the left and right chambers through holes in the dividing walls, so that the side chambers deploy a little slower than the center chamber.

When deployment of the entire airbag is nearly complete, the pressure in each chamber becomes uniform at a value that is little different from the internal pressure in a single-chamber airbag. Therefore, when the rider collides with the airbag, the center chamber no longer has higher pressure than the other chambers and there is no adverse effect on the airbag's performance.

## Back plate

The back plate is a special part that receives the force sustained by the airbag from the rider. With the use of a back plate we can expect that, regardless of motorcycle body layout, the airbag will be expected to function not only in frontal collisions but in oblique collisions as well. Before a collision, the back plate is stored with the airbag within the motorcycle body, but during collisions it deploys immediately with the airbag. At this time, as described above, the deployment force of the airbag is used to lift the back plate. There is also the advantage of a simpler total mechanism with the use of the airbag force.

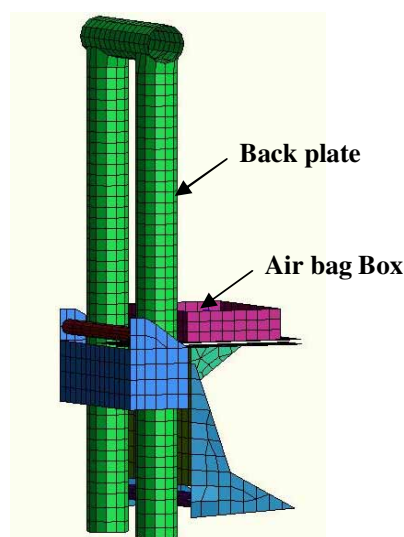


Figure 7. Back plate.

Considering the airbag function (that is to decelerate the rider), larger back plate height and width is desirable, but considering that the back plate is stored in the motorcycle and that it must be pulled up in a very short time, a smaller mass is advantageous. In determining the shape of the back plate, simulation of the rider dummy's motion using MADYMO and simulation to obtain deployment time using PAM-SAFE are very helpful.

The airbag and back plate are connected with a short belt. This belt is used when pulling up the back plate, but it also has another role. That role is to keep the airbag between the rider and back plate so that the airbag function is maintained even in cases of oblique impact.

## Experiments and simulations

**Sled test** Sled tests were conducted to confirm the characteristic functions of this airbag system; specifically, the function of lifting the back plate with the use of airbag deployment force, and the basic rider restraining function with the back plate. Two collision patterns were simulated, a frontal collision and an oblique collision. Figures 8 and 10 show the respective results of rider dummy motion in the sled tests and computer simulations for frontal and oblique collisions. The back plate was lifted by the airbag deployment force in each of these tests, confirming the fundamental possibility of lifting the back plate. In addition, in looking at dummy motion, even in tests when the sled was moved obliquely backward for an oblique collision, it was found that the dummy's lumbar area was restrained near to the seat.

Figure 9 shows the acceleration curve in the forward-backward direction of the dummy's chest corresponding to the case of a frontal collision.

The values estimated from this simulation show good agreement with the experimental values, confirming the validity of this modeling method. The influence of minor airbag specifications changes on dummy motion and other matters can be evaluated efficiently with the use of simulations.



Figure 8. Sled test - 1.

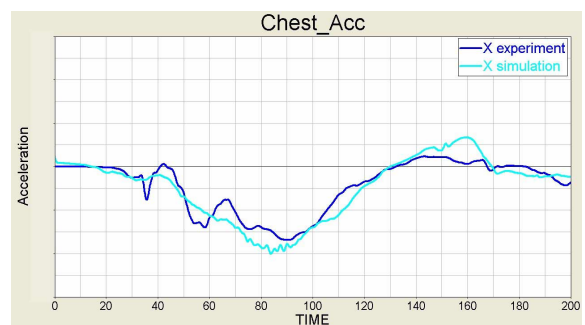


Figure 9. Chest acceleration.



Figure 10. Sled test - 2.

**Full-scale test** Since the fundamental rider restraining function was confirmed with sled tests, full-scale tests were performed next with an automobile as a collision object. Figure 11 shows a comparison of overall dummy motion with and without an airbag from 0 ms (at which time the first motorcycle/automobile contact occurs) to 500 ms at time intervals of 100 ms. In this case, a motorcycle traveling at 48 km/h collides at 90 degrees into the side of an automobile traveling at 24 km/h (configuration code '413-15/30' in ISO13232).

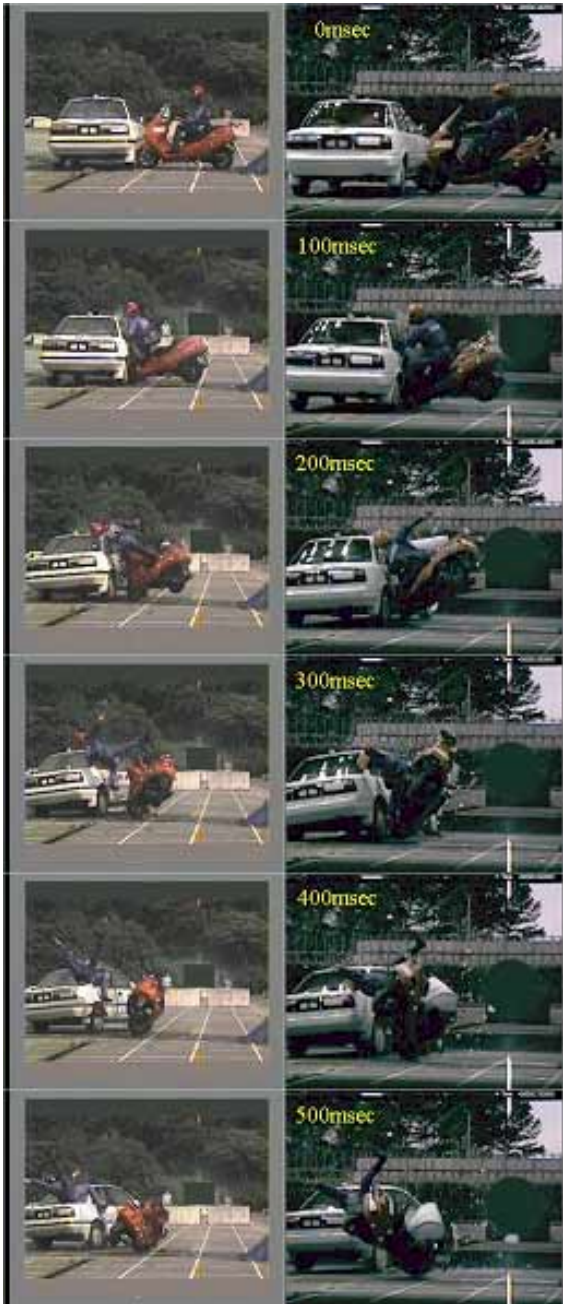


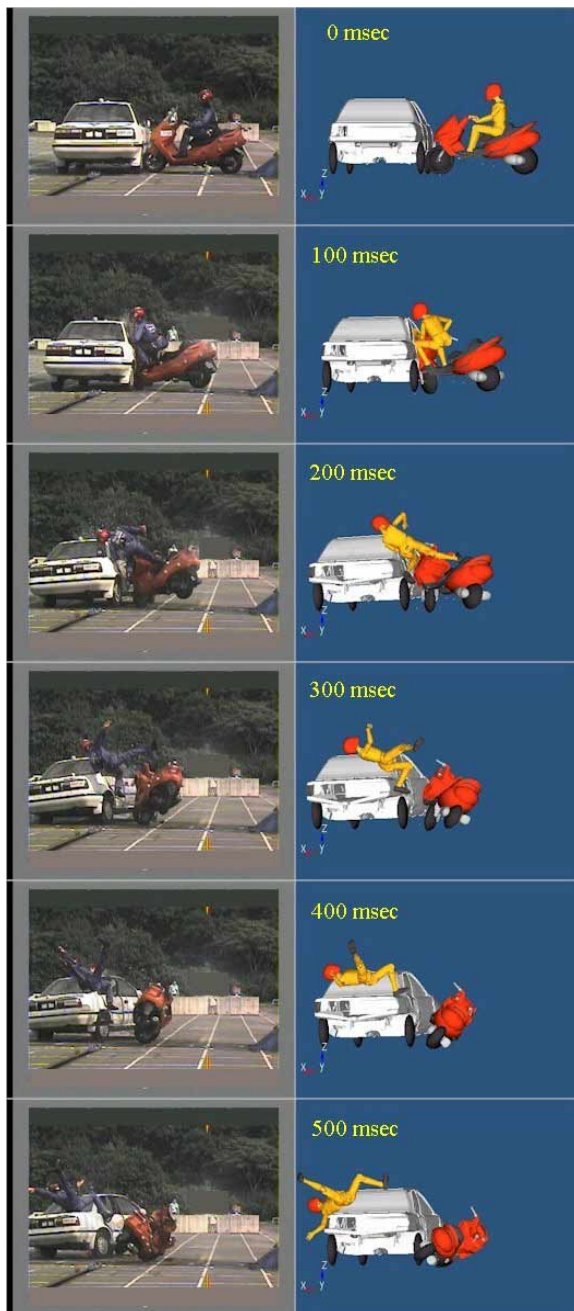
Figure 11. FST without/with airbag system.

Without an airbag, the dummy's head collided with the automobile roof edge with almost no deceleration, and large head acceleration (HIC 690) was shown. When the motorcycle was equipped with the present airbag, the dummy's lumbar region was relatively well restrained near the seat, its head only collided slightly with the rear part of the automobile, and the head acceleration (HIC 153) was also inhibited. In a comparison of the height to which dummies were thrown off the motorcycle, the height was found to be somewhat lower with the airbag, so that reduced injury in impacts with the ground can

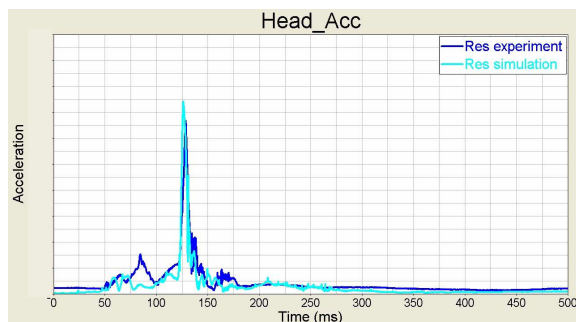
be expected because of the reduced potential energy. The lifting function of the airbag was confirmed even in the full-scale test. We are currently evaluating the effect of this airbag system on reducing the rider injury based on the simulation evaluation method with 200 configurations called for in ISO13232.

These full-scale tests are carried out not only to give a preliminary assessment for effectiveness of the airbag system, but also to validate the simulation model that should be used for 200 configurations of simulation according to ISO13232. Figures 12 and 14 show kinematic comparisons between FST and simulation from 0 ms to 500 ms at time intervals of 100 ms. The pictures of FST in Figure 12 are the same as the ones without the airbag in Figure 11 (ISO configuration code “413-15/30”.) In Figure 14, on the other hand, a motorcycle with the airbag system traveling at 48km/h crashes into the side of a stationary automobile at a right angle (ISO configuration code “413-0/30”.)

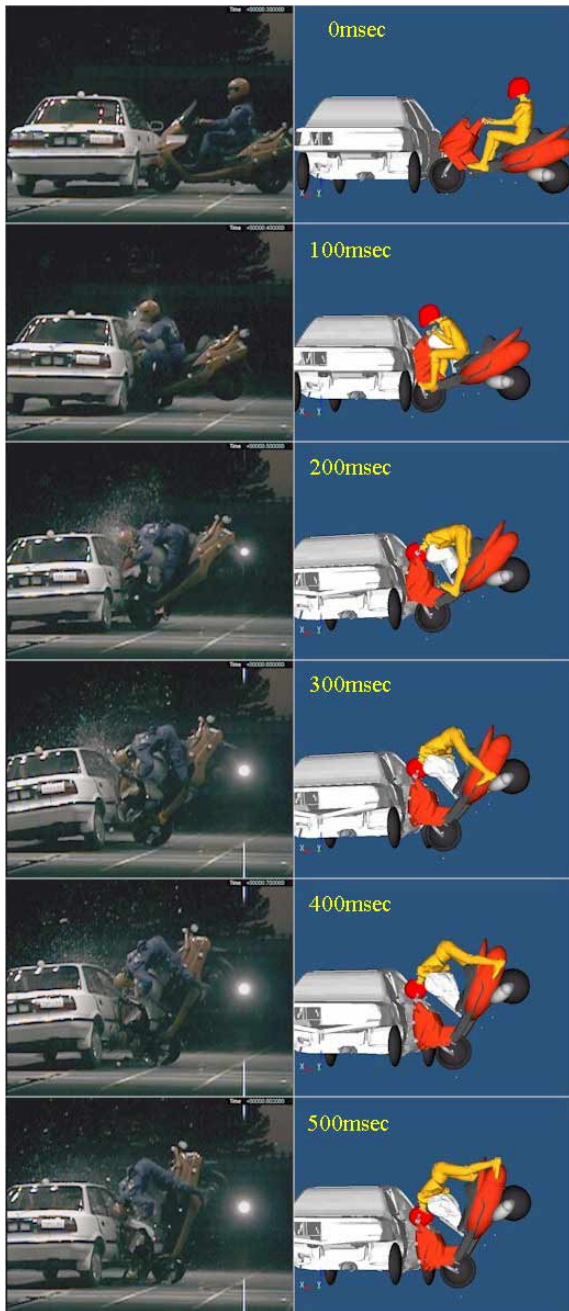
Figures 13 and 15 compare the head resultant linear acceleration between FST and simulation. The blue lines indicate test data and the light blue lines simulation results. These figures show good agreement both in the dummy general kinematics and head acceleration.



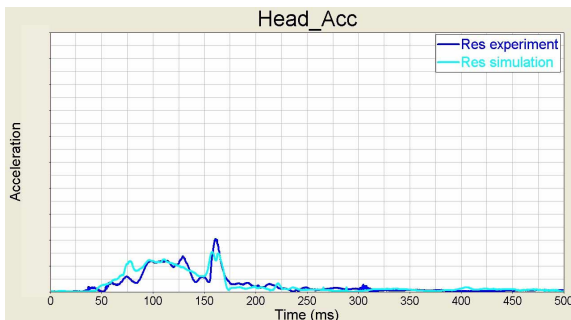
**Figure 12. Kinematic comparison (413-15/30) without airbag system.**



**Figure 13. Head resultant acceleration (413-15/30) without airbag system.**



**Figure 14. Kinematic comparison (413-0/30) with airbag system.**



**Figure 15. Head resultant acceleration (413-0/30) with airbag system.**

## Future issues

Issues we need to deal with next are, first, to optimize airbag shape, back plate shape, and their respective attachment positions. In addition, to confirm that this system is effective in reducing injury in various collision configurations, we will also need to conduct evaluations of effectiveness of the device based on ISO13232. The other tasks we need to do include development of a sensor and a control system to judge fire in airbags; investigation of the problem of out-of-position; investigation of the effect from differences in rider size and collision object; investigation of tandem riding; investigations of system reliability.

## CONCLUSIONS

In the preceding we introduced collision simulation technology that was essential in the development of our airbag system. Yamaha uses mainly calculations by MADYMO supplemented with those by PAM-SAFE. We also have proceeded with research on the possibility of a new type of airbag that restrains the rider in the lumbar area. It was shown in both the sled tests and full scale tests that it is fundamentally possible to lift the back plate using the deployment force of the airbag. This system was also shown, although in limited collision configurations, to be effective in reducing the rider injury. In the future we plan to improve and optimize this system, focus on and resolve the above-mentioned issues including evaluation of effectiveness of the system based on ISO13232, and investigate the possibilities for practical application.

## ACKNOWLEDGEMENTS

Finally, we would like to express our appreciation to the people at Toyoda Gosei Co., Ltd. for their tremendous cooperation in the development of this airbag system.

## REFERENCES

- (1) Deguchi M., Modeling of a motorcycle for collision simulation, 18th ESV Paper No. 157-O, 2003.

(2) Deguchi M., Simulation of motorcycle-car collision, 19th ESV Paper No. 05-0041, 2005.

# LONG LIGHTING SYSTEM FOR ENHANCED CONSPICUITY OF MOTORCYCLES

**Yojiro Tsutsumi**  
**Kazuyuki Maruyama**  
Honda R&D Co., Ltd.  
Japan  
Paper Number 07-0182

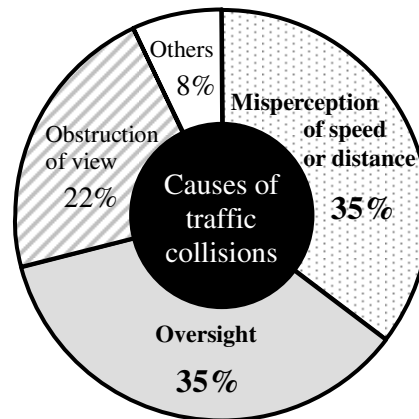
## ABSTRACT

The LONG (Longitudinal Oriented Normative time Gap compensation) concept describes a lighting system that enhances the conspicuity of motorcycles by enhancing the ability of oncoming drivers to evaluate the distance and speed of a motorcycle equipped with lighting in the LONG configuration. It is based on the hypothesis that a motorcycle observed at the same distance and speed as an automobile may be perceived farther away and traveling more slowly than the automobile, because of the motorcycle's higher lamp location and narrower lighting layout compared with that of an automobile. To address this the LONG configured are spread farther apart along a vertical axis compared to the relatively tightly grouped lighting layout found on a typical motorcycle. Knowledge of cognitive psychology is applied to the LONG system. To test the hypotheses behind the LONG concept, it has been evaluated by measuring critical time gap in right-turn across path scenario (in left traffic right-of-way countries). It is shown that motorcycles with the system have conspicuity on a level comparable to automobiles by measuring critical time gaps of about 20 experimental subjects. The effects of both the layout of the lighting and luminous intensity dependence are also reported.

## INTRODUCTION

It was reported that accident studies provided evidence that motorcycles were not perceived easily by road-users<sup>[1]</sup>. In order to enhance detectability of motorcycles in during daylight hours, the daytime use of headlamps on motorcycles began to spread in the late 1960s in the United States. It became mandatory in Japan in 1998. Daytime motorcycle lighting requirements spread widely, even in Europe, later on. This measure aimed at enhancing "detectability" among elements of conspicuity and did not aim at enhancing "evaluation of distance and speed" by oncoming traffic that is another element of conspicuity. As a matter of course, this measure does not show any benefits of reducing collisions during nighttime hours. Sugawara et al. reported that the analysis of the fatal motorcycle accidents (in which car drivers are responsible) from the Annual Traffic Accident Statistical Database of 1998, showed that

misperception of distance or speed of motorcycles was, together with failure of the car driver to be aware of motorcycles, a primary factor in accidents<sup>[2]</sup>. (Figure 1) Donne pointed out that this represents many collisions resulting from misperception of the distance or speed of the motorcycle involved in the crash in England<sup>[1]</sup>. In order to reduce these misperceptions of distance and speed, the LONG lighting system is being proposed to enhance the conspicuity of motorcycles by enhancing the ability of oncoming drivers to judge both the distance and speed of a motorcycle.



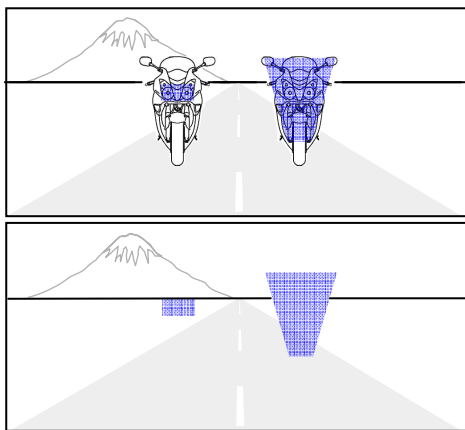
**Figure 1. Analysis of motorcycle traffic accidents in Japan (T. Sugawara et al., 2006)**

## LONG LIGHTING SYSTEM

### Fundamental Concept

We reported that there was the possibility that a lighting system can help to equalize conspicuity of various types of vehicles<sup>[3]</sup>. If some vehicles have higher conspicuity than other vehicles, the conspicuity of other vehicles may fall on a relative basis. The previous study aimed at reducing this effect. It may be desirable for motorcycles in mixed traffic to have conspicuity that is equivalent to that of automobiles. However the narrow frontal area and irregular outline of a motorcycle make it more difficult to recognize the whole body of a motorcycle than that of an automobile. Especially when viewed from the front a motorcycle headlamp and front position lamps are conspicuous (even if these lamps are turned off) and these lamps are considered as the keys to perception of motorcycle distance and speed.

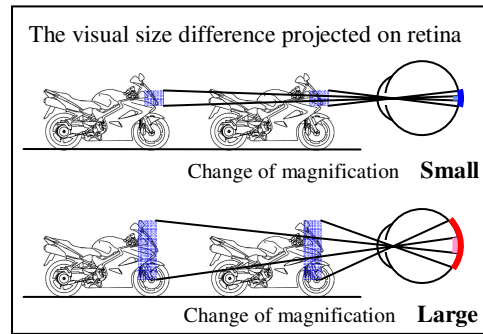
If the separation between a subject and the horizon line in a visual field becomes longer, the subject is perceived as nearer. This describes a type of “perspective effect”<sup>[4][5][6]</sup>. Support for this hypothesis that human’s visual recognition uses the angular declination below the horizon for distance judgment has been provided<sup>[7]</sup>. Ordinary motorcycles have a comparatively high layout position of headlamps and front position lamps, and don’t have conspicuous lighting in the vicinity of a road surface. Therefore the distance to the motorcycle may be perceived as being further away than actual distance. In order to draw attention to the lower portion of motorcycles, lamps are located low and nearer to the road surface, for example in the lower part of the front fork. This is expected to allow an observer to more accurately judge the relative distance of a motorcycle. (Figure 2)



**Figure 2. Principle of enhancing a sense of distance**

Considering the approaching motorcycle as it relates to the optics of the observer, if the visual size of an approaching subject is small, the expanding size of the image on the retina of the observer would be smaller and the image on the retina would grow less quickly than a larger object, making it more difficult to accurately judge the speed of the approaching motorcycle. We reported that if the visual size of an approaching vehicle is large, the approaching speed could be recognized from a greater distance<sup>[8]</sup>. Since the headlamp and the front position lamp of ordinary motorcycles are located within a narrow area, the images on the retinas of the observer are small. Therefore it may be difficult to perceive the speed of the approaching motorcycle. In the case of ordinary motorcycles, vehicle height is comparatively tall, although the motorcycle’s width is narrow. In order to emphasize the longitudinal size of the body, lamps are distributed longitudinally, spanning from a low position on the front fork to a high position on the body. This prevents the observer

from recognizing the size of the body as being small, and aids the observer in more accurately judging the speed of an oncoming motorcycle. (Figure 3) It was reported that if the visual size of the subject is large, the sense of distance is also affected and the subject is perceived being closer to the observer<sup>[9]</sup>. (Figure 2)



**Figure 3. Principle of enhancing a sense of speed**



**Figure 4. LONG lighting system**

Using these concepts, the LONG lighting system is proposed as a method to enhance motorcycles’ conspicuity. Specifically, the LONG concept aids an observer’s ability to more correctly judge both the distance and speed of an oncoming motorcycle, and allowing the observer to perceive approaching motorcycles more equally to an automobile. Figure 4 shows an example of a LONG frontal lighting configuration applied to a motorcycle. The name LONG comes from the emphasis on the longitudinal size of the motorcycle body and distribution of the lamps, as well as how the concept aids in



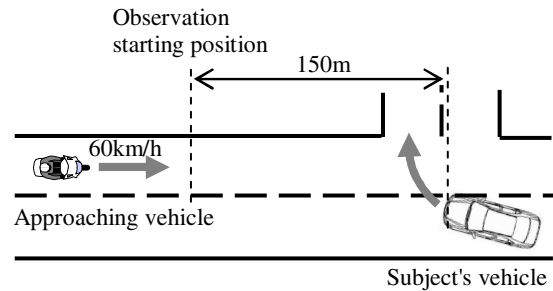
compensating the critical time gap of motorcycles to become longer and more equivalent to that of automobiles.

### Evaluation Methodology

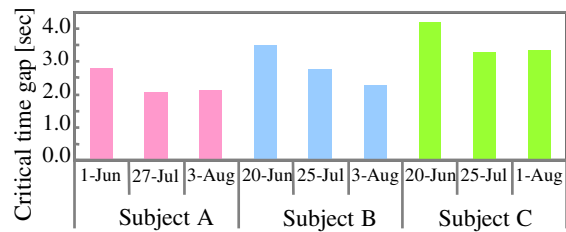
The evaluation method is based on the belief that a driver synthetically judges the speed, distance of approaching vehicles and one's own speed, width of the road, etc., then uses this information to make a decision whether or not to turn to the right (in left-hand traffic right-of-way countries). This behavior is called the *gap acceptance behavior in right-turn across path scenarios*. If a vehicle approaches more quickly from the opposite direction, a driver chooses not to make a right-turn at a crossing. The passage time from the moment a driver chooses to give up until the approaching vehicle passes the driver's side is called the *critical time gap (CTG) in right-turn across path scenario*<sup>[10]</sup>. If CTG of various vehicles is compared, a quantitative measure of those vehicles' conspicuity relative to the observer's judgment of distance and speed can be made. The LONG lighting system has been quantitatively evaluated by measuring CTG in a right-turn across path scenario.

Figure 5 shows a schematic plan of a right-turn across path scenario of the type used in CTG measurements. The instruction to experimental subjects is that "you are waiting to make a right-turn at the crossing. If you judge that you must give up making the right-turn if a vehicle coming from the opposite direction approaches before you can safely make the right turn, please step on the brake pedal immediately". The velocity of the stimulus vehicle was set at 60 [km/h]. In order to control the stimulus to the experimental subject, the experimental subject starts the observation of the stimulus vehicle at the moment when the stimulus vehicle passes through the position of 150 [m] from the experimental subject. First, the experimental subject turns his eyes downward so that the experimental subject cannot see the stimulus vehicle. Next, the experimental subject begins observation of the stimulus vehicle at the moment when a signal sound from a sensor that senses a passing vehicle is heard. In order to minimize the learning effect on subjects, observation was stopped at the moment of stepping on the brake pedal by turning the subject's eyes downward again. The front grille of the subject's vehicle is equipped with a millimeter wave radar system. The speed and distance of the stimulus vehicle are simultaneously measured in a period of 0.1[sec] by the radar. The CTG is calculated from the speed and distance of the stimulus vehicle at the moment of stepping on the brake pedal. Five CTG measurements are

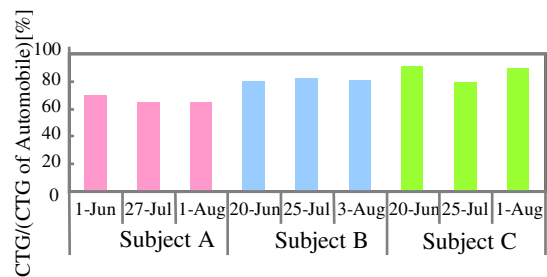
continuously performed to the same stimulus vehicle, and the mean of five values is used as the value of the stimulus vehicle.



**Figure 5. Schematic plan of right-turn across path scenario, as used in the study**



**Figure 6. CTG of an ordinary motorcycle in nighttime**



**Figure 7. CTG ratio of an ordinary motorcycle compared to an automobile**

Figure 6 depicts an example of the CTG measurement of an ordinary motorcycle in nighttime. It contains the results of three experimental subjects containing three data of the same motorcycle measured on different days. The standard deviation of the CTG for experimental subject A, B and C divided by the corresponding mean is 0.25, 0.30 and 0.21, respectively. There is considerable variation by measurement date in spite of the use of the same stimulus vehicle. Also in the past study, the variation in CTG<sup>[11]</sup> is referenced. Based on these results, it seems that CTG is not stable enough to independently represent conspicuity. We noted that

the CTG of the automobile measured on the same day had the same variation as that of the motorcycle. The CTG ratios of the motorcycle to the automobile are shown in Figure 7. The standard deviation of CTG ratio of the experimental subjects A, B and C divided by the corresponding mean is 0.06, 0.02 and 0.10, respectively. The variation of the value by measurement date clearly becomes small. Therefore, it is possible to isolate conspicuity from the variation of each evaluation day by normalizing with the CTG of the automobile measured on the same day. The fundamental conceptual goal of the system is to make the conspicuity of motorcycles equivalent to that of automobiles. A comparison with automobiles supports this fundamental concept. We chose to utilize the CTG ratio of the motorcycle to the automobile when both are measured on the same day as the variable that evaluates the conspicuity based on distance and speed.

### Enhanced Motorcycle Conspicuity

The enhanced conspicuity of motorcycles with a LONG lighting system is evaluated by CTG measurement. The photograph of the motorcycle used for a stimulus in the measurement is shown in Figure 8. This Honda XR250 Motard motorcycle is an on-road type with 250 [cc] engine displacement, with a LONG lighting system adapted to the front of the motorcycle. The large-sized amber-colored lamps (from a Honda CB1300SF) are used for the upper lamps of the system, and the small-sized lamps (from a Honda XR250) are used for the lower lamps. In order to change the luminous color to white, the original amber lenses were replaced with clear lenses. The height of two lower lamps (H) is set at 225 [mm], and the horizontal space between them is set at 300 [mm]. The upper lamps were set at a height of 950 [mm] above the lower lamps, and were horizontally spaced at 750 [mm] apart. In addition, a PWM circuit was added to allow the lamp luminous intensity of the LONG lighting system to be adjusted freely, is equipped. This motorcycle has special structural stays for headlamps so that many types of motorcycles can be simulated. This motorcycle is equipped with a single multi-reflector headlamp (55/60W for CB1300SF) at a height of 825 [mm]. The photograph of the automobile used for a stimulus in the testing is shown in Figure 9. The automobile is Japanese market minivan-type passenger car (Honda STEPWGN) of 2000 [cc] displacement volume, and the body color is white. The vehicle height is 1770 [mm] and the vehicle width is 1695 [mm]. The height of the headlamps is 800 [mm]. The space between them is 1350 [mm].

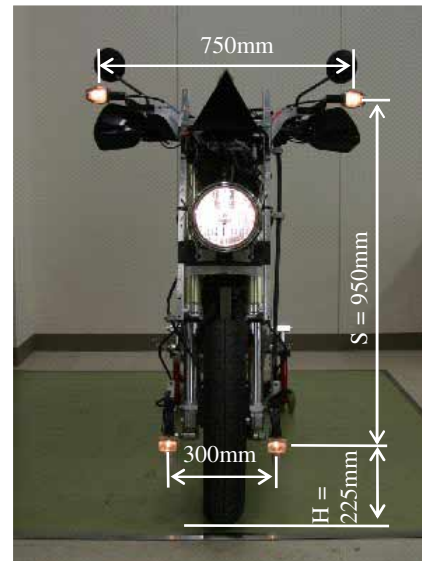


Figure 8. The motorcycle used for the study

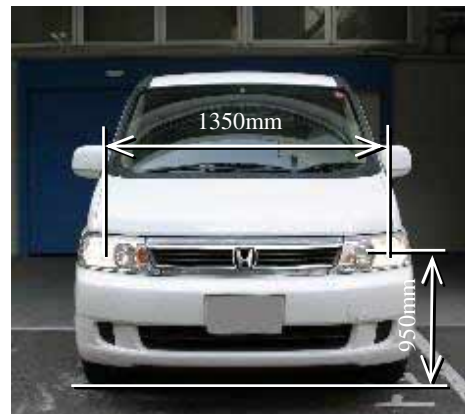
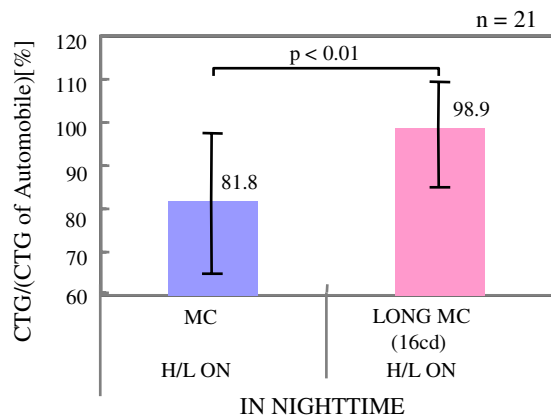


Figure 9. The automobile used for the study

The mean of the CTG ratios of the motorcycle with conventional lighting (MC) and the motorcycle equipped with a LONG lighting system (LONG MC) to an automobile in nighttime is shown in Figure 10. The experimental subjects were 21 people (18 males, 3 females, from 23 years of age to 52 years old) who drive an automobile every day. The range bar on the chart shows the maximum and the minimum measurements for each data set. The luminous intensity of the four lamps of the LONG lighting system was adjusted to 16 [cd], respectively. This intensity is equal to the luminous intensity of the ordinary position lamps for motorcycles. The low-beam headlamps of all the measured stimulus vehicles were switched on. The velocity of the stimulus vehicles was 60 [km/h]. The course used for the evaluation was illuminated by normal overhead road illumination. The illumination was about 6 [lx]. The CTG ratio of the MC to the automobile is 81.9%, and it turns out that the CTG of MC is about 18% smaller than of the automobile. The mean of the automobile's CTG is 4.0 [sec], and the reduction of

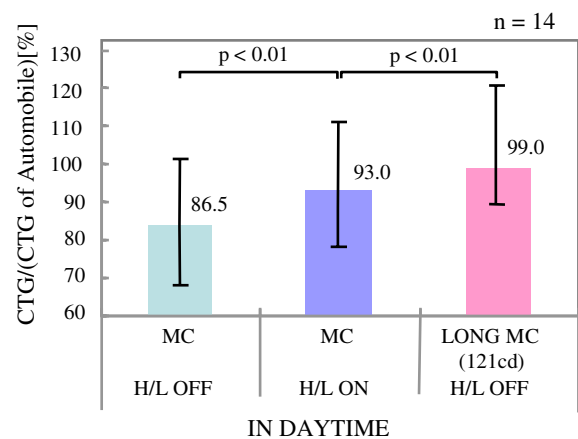
the CTG is equivalent to 0.72 [sec]. The minimum of the CTG ratio of MC is about 65%, and the reduction of the CTG is equivalent to about 1.4 [sec]. It is shown quantitatively that motorcycles at the same distance and speed as automobiles are perceived being farther away and as traveling at a lower speed than automobiles. On the other hand, the CTG ratio of a LONG MC to the automobile is 98.5%, and it turns out that LONG MC has a sense of speed and distance almost equivalent to an automobile.



**Figure 10. Enhanced conspicuity in nighttime**

The mean of the CTG ratios of the MC and the LONG MC compared to the automobile in daytime is shown in Figure 11. The experimental subjects were 14 people (12 males, 2 females, from 23 to 52 years old) who drive an automobile every day. The range bar shows the maximum and the minimum measurements for each data set. The MC was measured on the two conditions that the headlamp was turned off (H/L OFF) and the low-beam headlamp was turned on (H/L ON). The headlamp of the LONG MC was turned off. The luminous intensity of the four lamps of the LONG lighting system was adjusted to 121 [cd], respectively. This intensity is the luminous intensity of the ordinary winker lamps for motorcycles. The velocity of all of the measured stimulus vehicles was the same 60 [km/h] as the measurement in nighttime. The sky illumination on the course is from 4410 [lx] to 33500 [lx]. Since this measurement was performed over seven days, the variation of the sky illumination is large. The headlamps of the automobile were switched off. The CTG ratio of MC (H/L OFF) to the automobile was 86.5% and it turns out that the CTG is 13.5% smaller than that of the automobile. It was shown quantitatively that motorcycles at the same distance and speed as automobiles are perceived as being farther away and traveling at a lower speed than the automobiles in the same daytime conditions. The CTG ratio of MC (H/L ON) to the automobile is 93% and it turns out that the CTG of MC (H/L ON)

is 7% larger than the CTG of MC (H/L OFF). This shows that turning on the motorcycle's headlamp in daytime enhances the ability to sense both the distance and speed of an approaching motorcycle. But the CTG was 7% smaller than the automobile. Under these conditions it was not possible to compare the results for the motorcycle to an equivalent automobile by only switching on a headlamp. On the other hand, the CTG ratio of the LONG MC to the automobile is 99%, and it turns out that it is almost equivalent to the CTG of the automobile. This shows that the LONG lighting system makes the motorcycle's conspicuity of distance and speed judgment equivalent to an automobile. As reference information, the mean of the automobile's CTG in daytime is 4.0 [sec], and the same subjects' mean of it in nighttime is 4.1 [sec], and these values are almost same.

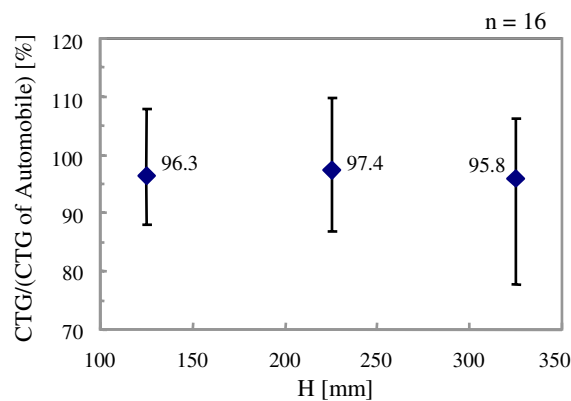


**Figure 11. Enhanced conspicuity in daytime**

### Lamp Layout Dependence

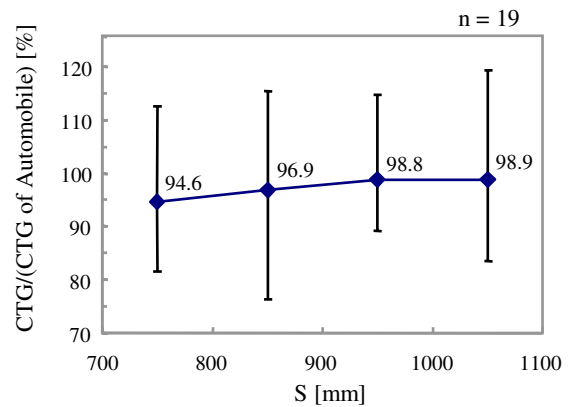
The dependence on the layout of the lamps to enhance conspicuity was measured in nighttime. The longitudinal space between the upper lamps and the lower lamps (S) as well as the height from the ground of the lower lamps (H) were identified as the parameters of the lamps layout. The horizontal space between the two upper lamps was fixed at 750 [mm], and the horizontal space between the two lower lamps was fixed at 300 [mm] (refer to Figure 8). The luminous intensity of four additional lamps of the LONG lighting system were adjusted to 16 [cd], respectively. The low-beam headlamps of all the measured stimulus vehicles were switched on. The velocity of all the measured stimulus vehicles was 60 [km/h]. The course used in the measurements was illuminated by road illumination. The illumination is about 6 [lx]. Figure 12 shows the dependence of the CTG ratio on parameter H. The CTG ratios were measured with the lighting affixed to the motorcycle

at three different levels: (125 [mm], 225 [mm], 325 [mm]) of the parameter H. The parameter S is fixed at 950 [mm]. Experimental subjects included 16 people (14 males, 2 females, from 23 to 52 years old) who drive an automobile every day. The error bar shows the full range from maximum to minimum. In the range of parameter H was set in the measurement, it seems that CTG ratio is not dependent on the parameter H. It is expected that the observer's ability to accurately judge distance is enhanced and the CTG ratio increases as parameter H decreases. It seems that additional studies using a range of larger H than 325 [mm] needs to be completed in order to observe the relationship between parameter H and CTG. The mean of CTG of the automobile measured on the same day was 4.0 [sec], and the means of CTG of the motorcycle with LONG lighting system were 3.92 [sec] (H=125 [mm]), 3.94 [sec] (H=225 [mm]) and 3.90 [sec] (H=325 [mm]).



**Figure 12. CTG ratio dependence on height (H) of lower lamps in nighttime**

Next, the dependence on parameter S of the CTG ratios is shown in Figure 13. The CTG ratios were measured at 4 levels (750 [mm], 850 [mm], 950 [mm] and 1050 [mm]) of the parameter S. The parameter H is fixed to 225 [mm]. This experiment included 19 subjects (17 males, 2 females, from 23 to 52 years old) who drive an automobile every day. The error bar shows the maximum and the minimum ranges. It turned out that the CTG ratio increases as parameter S increases when the range of parameter S is between 750 [mm] and 950 [mm]. It is expected that the observer's ability to judge the accuracy of the oncoming motorcycle's distance and speed is enhanced and the CTG ratio increases as parameter S increase. The data from this experiment agrees with this expectation.



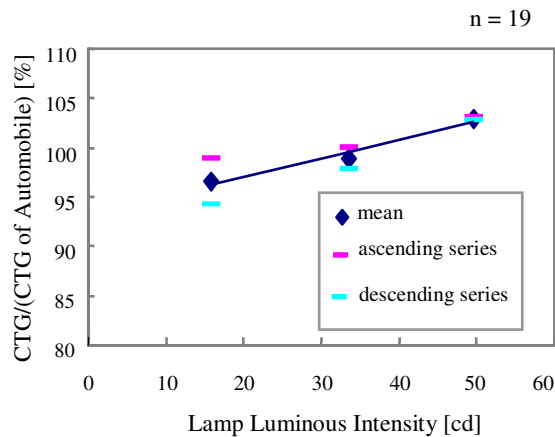
**Figure 13. CTG ratio dependence on space (S) between upper lamps and lower lamps in nighttime**

As a result of this data, we believe that drivers mainly use the size of the motorcycle's conspicuous parts for to estimate the distance and speed of the approaching vehicle independently in a right-turn across path scenario.

#### Lamp Luminous Intensity Dependence

The effect of lamp luminous intensity on conspicuity was measured in nighttime. The layout parameters of the lamps are H=225 [mm] and S=950 [mm]. The CTG ratios were measured at three different lamp luminous intensity levels: 16 [cd], 34 [cd] and 50 [cd]. The low-beam headlamps of all the measured stimulus vehicles were switched on. The velocity of each of the measured stimulus vehicles was 60 [km/h]. The course used in the measurements was illuminated by normal road illumination of about 6 [lx]. Experimental subjects included 19 people (17 males, 2 females, from 23 to 52 years old) who drive an automobile every day.

The preliminary experiment showed that stimulus order effect influences the results. In order to minimize the influence of this effect, the ascending series (order of 16 [cd], 34 [cd] and 50 [cd]) and the descending series (order of 50 [cd], 34 [cd] and 16 [cd]) were measured for each experimental subject, and the mean of the values at the same level was adopted as the measure of central tendency at the level. The CTG ratio dependence on lamp luminous intensity in nighttime is shown in Figure 14. It turned out that the CTG ratio increases as the lamp luminous intensity increases. Since a lamp luminous intensity of zero describes a motorcycle without a LONG lighting system, the CTG ratio at zero is estimated at about 81.9 [%], as shown in Figure 10. We expect that the CTG ratio decreases rapidly as the lamp luminous intensity approaches zero in the range smaller than 16 [cd].



**Figure 14. CTG ratio dependence on lamp luminous intensity in nighttime**

## CONCLUSIONS

The LONG lighting system is proposed as a method of enhancing the conspicuity of motorcycles, specifically to enhance the ability of the driver of an oncoming vehicle to judge distance and speed of a motorcycle to a degree of accuracy equivalent to an automobile.

The enhancement effect of LONG on the judgment of the distance and speed of a motorcycle equipped with the LONG lighting system is evaluated by the CTG ratio measurement, compared to an automobile in similar nighttime and daytime conditions.

In nighttime, it is shown that ordinary motorcycles at the same distance and speed as automobiles may be perceived as being farther away and seem to be traveling at a lower speed than an automobile. The LONG lighting system with the same lamp luminous intensity as conventional motorcycle position lamps makes the motorcycles' conspicuity for an oncoming driver's ability to judge the motorcycle's distance and speed equivalent to that of an automobile.

In daytime, it is shown that motorcycles with unlit headlamps traveling at the same distance and speed as an automobile are perceived as being farther away and traveling at a lower speed than an automobile. The motorcycle's conspicuity related to an oncoming driver's ability to accurately judge the motorcycle's distance and speed does not become equivalent to an automobile, even if the low-beam headlamp is turned on. By adding the LONG lighting system with the same lamp luminous intensity as wipers improves the motorcycle's conspicuity related to the oncoming driver's ability to judge the motorcycle's distance and speed equivalent to that of an automobile.

The effect of the layout of the lamps on conspicuity was measured at night. The results show that the lamp layout has a greater effect on conspicuity as the longitudinal space between the

lower lamps and the upper lamps increases within the range of 750 [mm] to 950 [mm].

The effect of lamp luminous intensity on conspicuity was measured at night. This showed that conspicuity was enhanced as the lamp luminous intensity increased.

In order to avoid mud and the breakage by a stone etc., we suppose that the lower lamps of the system are located near the axle of a front wheel. The lamps located in this position vibrate greatly during a run. The problem at the time of applying this technology to a mass-production model is the durability of the lamps to this vibration.

## REFERENCES

- [1] G. L. Donne, "Research into Motorcycles Conspicuity and its Implementation.", Proceedings: International Congress and Exposition (1990): Society of Automotive Engineers SAE Paper 900749
- [2] T. Sugawara et al., "Enhancement of Motorcycle Conspicuity Using Brain Activities", Review of Automotive Engineering, Vol.27, No.3 (2006)
- [3] K. Maruyama et al., "A Study of New Lighting System for Better Conspicuity of Motorcycle", Review of Automotive Engineering, Vol.27, No.4 (2006)
- [4] J. J. Gibson, "The Perception of the Visual World", Houghton Mifflin, Boston, 1950
- [5] B. E. Dunn et al., "Relative height on the picture plane and depth perception", Perceptual and Motor Skills, 21, pp.227-236, 1965
- [6] W. Epstein, "Perceived depth as a function of relative height under three background conditions", Journal of Experimental Psychology, 72, pp.335-338, 1966
- [7] Teng Leng Ooi et. al., "Distance determined by the angular declination below the horizon", Nature 414, pp.197-200 (8 November 2001)
- [8] K. Maruyama et al., "A Study of New Lighting System for Better Conspicuity of Motorcycle", Journal of Society of Automotive Engineers of Japan, Vol.37, No.5, pp.137-142 (2006)
- [9] W. C. Gogel, "The absolute and relative size cues to distance", American Journal of Psychology, 82, 228-234, 1969
- [10] T. Miura, A preliminary study of gap acceptance behavior and its perceptual factors, Bulletin of the Faculty of Human Sciences, Osaka University, Vol.6, pp.37-41 (1980)
- [11] H. Ueno et. al., "Analysis of Driving Behavior in Right Turns", Journal of Society of Automotive Engineers of Japan, Vol.46, No.9, 1992

# INJURIES AMONG MOTORIZED TWO-WHEELERS IN RELATION TO VEHICLE AND CRASH CHARACTERISTICS IN RHONE, FRANCE

**Aurélie Moskal**  
**Jean-Louis Martin**  
**Erik Lenguerrand**  
**Bernard Laumon**

UMRESTTE, UMR T 9002, INRETS, Université Lyon 1, InVS, Bron, F-69675  
Université de Lyon, Lyon, F-69003  
France  
Paper Number 07-0232

## ABSTRACT

We described injuries among helmeted motorized two-wheelers injured in a road crash between 1996 and 2003 and recorded by the Rhone Road Trauma Registry in France. The registry data were linked to police data for 3727 riders to describe injuries according to vehicle and crash characteristics.

Extremity injuries were the most common injuries sustained. A substantial proportion of riders sustained head, chest abdominal and spinal injuries, which tended to be severe. Half of severely injured riders sustained severe chest injuries and 44.8% suffer from severe head injuries.

Whatever the body region injured, head-on collisions accounted for more than 30% of injuries. A high proportion of head, facial, chest, abdominal and spinal injuries occurred in single vehicle crashes with a fixed object. Compared to single vehicle crashes with no object hit, those with a fixed object resulted in a higher risk of head, facial, chest and abdominal injury. Collisions between the front of the two-wheeled motorized vehicle and the side of another vehicle resulted in a higher risk of upper extremity injury than single vehicle crashes with no object hit. Head-on, rear-end, broadside and multiple collisions resulted in a higher risk of lower extremity injury than single vehicle crashes with no object hit. The highest risk of lower extremity injury was observed for broadside collisions. Motorcyclists, which accounted for 62.4% of injured riders, had a higher risk of chest, abdominal, spinal and upper extremity injuries than moped riders. The risk of facial injury was greater for moped riders.

The use of safety devices must be promoted as well as their improvement. The attention given to head protection shouldn't ignore the vulnerability of other body regions. Public awareness campaigns on motorized two-wheeler vulnerability and their crash risks, the improvement of driver experience as well as road infrastructure could contribute to reducing crashes.

## INTRODUCTION

In France, according to Road Crash statistics based on police records, motorized two-wheelers

accounted for 21.7% of deaths in road crashes and 32.5% of those severely injured (ONISR, 2005). In the fatal crashes they were involved in, motorized two wheelers represented 90% of fatally injured victims (ONISR, 2005).

Epidemiological studies conducted on motorized two-wheeler crashes have aimed to identify risk factors that increase injury severity or to study injury patterns sustained as a result of two-wheeled motorized vehicle crashes, with regard to frequency, nature and severity. Some studies are based on police data and others on medical data coming from emergency, hospital or registry records. Police reports are the most complete source of information available about the crash. Many factors such as vehicle characteristics, crash characteristics and crash conditions have been pointed out by recent studies on the subject as important factors in predicting injury severity (Lin et al. 2003; Lin et al. 2001; Peek-Asa and Kraus 1996; Quddus et al. 2002; Zambon and Hasselberg 2006). Few studies combined both information from medical and police sources and have been published for motorised two-wheelers (Peek-Asa and Kraus 1996; Peek et al. 1994; Richter et al. 2001). In order to broaden our understanding of motorized two-wheeler crashes, studies that provide injury pattern descriptions and contribute to improve knowledge of mechanisms by which crashes cause injury are welcome. Information on vulnerable body region to protect will make possible to propose recommendations for rider protection.

This study was conducted on motorized two-wheelers fatally and non-fatally injured, recorded in the Rhone Road Trauma Registry. For a sizeable group of these riders, information on both the crash characteristics and the medical diagnoses were available, thanks to police reports. In France, helmet use is mandatory by law from 1979 for riders of all type of motorised two-wheeled vehicles (ONISR, 2005). This study focused on helmeted riders. The primary objective of this study was to describe injuries among helmeted motorized two-wheelers receiving medical care after a crash in the Rhone County in France. Specifically, we sought to focus on severe injuries, which are life-threatening or fatal, and may lead to long term

disability and impairment. The secondary objective was to describe injuries among helmeted motorized two-wheelers in relation to vehicle and crash type.

## **METHODS AND DATA SOURCES**

### **The Rhone road trauma registry**

This study is based on the road trauma registry (Laumon et al. 1997), which has been in use since 1995 in the Rhone region of France (population, 1.6 million inhabitants; main city, Lyon). The registry covers all victims from road crashes that occur in the Rhone county and seek care in health facilities, whether they are hospitalised or not. Data are collected by the medical units involved in the health care of crash victims of the county and its close surroundings: it includes some 201 health care units, from emergency departments and follow-up services (intensive care, surgery and rehabilitation units). The registry is not restricted to only motor vehicle crashes: crashes with pedestrians are also included. This registry has been approved by the French National Registry Committee.

Information collected by the registry for each victim contains the victim's characteristics (name, gender, and date of birth), a few crash characteristics (crash location, date, time of the crash, road user type and riding position, safety device use such as helmet, and type of collision) and injury assessment. Victims are defined as road users sustaining at least one injury. The registry provides a complete injury assessment coded according to the Abbreviated Injury Scale (AIS), 1990 revision (AAAM, 1990). The AIS divides injuries into body region, type, nature and severity. The AIS uses nine body regions including head, chest, abdomen, neck, face, upper extremity, lower extremity and external. Each injury is assigned a severity code, ranging from AIS 1 (minor) to AIS 6 (unsurvivable injury). Each victim could have more than one body region affected and could have more than one injury to a specific injured body region. The overall severity of a victim with multiple injuries can be measured with the maximum Abbreviated Injury Severity (MAIS) Score. It denotes the most severe injury.

### **Police traffic crash data**

The French police are required by law to fill in a crash report for every road crash causing at least one victim. A road crash is defined as a crash occurring on the network open to public traffic and involving at least one vehicle. The police crash report includes information on everyone involved in the crash (non-injured, slightly injured, severely injured or dead) and detailed information on the crash and the vehicles involved. However,

information on the people involved is limited. For each identified crash, the following information were used: vehicle type involved in the crash (moped, motorcycle), crash location (urban or rural area), day of the week (weekday, weekend), time of the crash (daytime, night), and type of road at the crash location (motorway, main road and secondary highway, minor road/street, other). The nature of the crash opponent was defined in 6 categories: single vehicle (no opponent, the two-wheeled motorized vehicle was the only moving vehicle), pedestrian/bicyclist, two-wheeled motorized vehicle (TWMV), car, truck, other. Collision type was defined according to the nature of crash opponent (motorized, non motorized vehicle) and impact location on the TWMV: single vehicle crash - no object hit; single vehicle crash - fixed object hit; head-on collision between the TWMV and another motorized vehicle; collision with pedestrians or bicyclists; collision between the front of the TWMV and the rear of another motorized vehicle; collision between the front of the TWMV and the side of another motorized vehicle; broadside collision (i.e. the TWMV collided with any other motorized vehicle in a broadside of any angle); rear-end collision (i.e. a motorized vehicle struck the rear of the TWMV); multiple collision or undefined collision.

### **Analysis**

Firstly, we identified all fatally or non-fatally injured motorized two-wheelers who wore a helmet recorded by the road trauma registry in the Rhone from 1996 to 2003. It is now clear that unhelmeted riders are more likely to suffer a head injury and to be critically injured compared to helmeted riders (Ankarath et al. 2002; Rowland et al. 1996; Sarkar et al. 1995). Helmets provide protection for all types and locations of head injuries. They are not associated with an increase in the occurrence of other injuries (Richter et al. 2001; Sarkar et al. 1995). As unhelmeted riders accounted for only a small proportion of the riders in the Rhone road trauma registry (6.0%), we focused our analysis on helmeted riders.

Fatally injured riders without injury coding were excluded. We described the body region injured according to injury severity. Then the nature of severe injuries was detailed. Victims were considered severely injured if they sustained at least one injury greater than or equal to AIS severity level 4 (AIS4+). Severely injured riders were fatally or non-fatally injured. This choice of severity level implied that we emphasized life-threatening injuries (such as injury to internal organs or crushing injuries), that could lead to severe impairment and disability. In the AIS classification, all upper extremity injuries and with a few exceptions, all lower extremity injuries are

coded with severity level ranging from 1 to 3. It is also the case of uro-genital injuries with severity level below 4. Although these injuries could be severe and could account for high degree of impairment and disability, they are not life threatening in the AIS classification.

Then, the registry medical data were linked to the French police data recorded between 1996 and 2003 for the Rhone County. Data were linked using a semi-automated record-linkage procedure (Amoros et al. 2006; Laumon and Martin 2002) at the victim level. Linking variables were date and time of crash, crash location, type of road user, date of birth (year and month) and gender. This selection process led to the exclusion of data not reported by police records. These crashes corresponded to crashes not-reported to the police (crashes when no-one called the police) or not-reported by the police (when police did not write a crash report even though present at the crash scene, or omitted some of the victims within the reported crash). The level of being reporting varies according to injury severity (Amoros et al. 2006). Although crashes resulting in fatally or severely injured road users are well reported by the police,

this is not the case of crashes where road users are slightly injured. Therefore, our sample of riders involved in crashes identified by both sources represents more seriously injured riders than the overall population of injured riders.

For the victims identified as common to the Registry and the police file, we described the main vehicle and crash characteristics according to overall injury severity and we examined the injured body region according to vehicle and collision type. The  $\chi^2$  test was used for statistical analyses. A p-value below 0.05 was considered statistically significant. Logistic regression analyses were performed, with crude odds ratios (OR) and corresponding confidence intervals to assess the risk of being injured in each body region associated with collision type and vehicle type. Data analyses were done with SAS software.

## RESULTS

Over the 1996-2003 observation period, 14749 helmeted injured riders were recorded in the Rhone Road Trauma Registry and had a complete injury coding.

**Table 1.**  
**Body region injured, injury type and AIS Group among the 14749 helmeted motorized two-wheelers, Rhone Trauma registry, 1996-2003**

Injury sustained	AIS>0 N=14749		AIS4+ N=328		% of AIS≥4
	No. of Riders	%	No. of Riders	%	
<b>Head</b>	<b>1640</b>	<b>11.1</b>	<b>147</b>	<b>44.8</b>	<b>9.0</b>
Cranial or intracranial injuries	187	11.4	118	80.3	63.1
Loss of consciousness	1328	81.0	8	5.4	0.6
Head/nerves	208	12.7	23	15.6	11.1
<b>Face</b>	<b>990</b>	<b>6.7</b>	<b>8</b>	<b>2.4</b>	<b>0.8</b>
<b>Neck</b>	<b>575</b>	<b>3.9</b>	<b>2</b>	<b>0.6</b>	<b>0.3</b>
<b>Chest</b>	<b>1480</b>	<b>10.0</b>	<b>164</b>	<b>50.0</b>	<b>11.1</b>
<b>Abdominal</b>	<b>800</b>	<b>5.4</b>	<b>45</b>	<b>13.7</b>	<b>5.6</b>
<b>Spinal</b>	<b>1251</b>	<b>8.5</b>	<b>32</b>	<b>9.8</b>	<b>2.6</b>
Cervical	876	70.0	14	43.8	1.6
Thoracic	149	11.9	17	53.1	11.4
Lumbar	282	22.5	1	3.1	0.4
<b>Upper extremity</b>	<b>6679</b>	<b>45.3</b>			
Shoulder/Upper arm	3203	48.0			
Forearm/ Elbow	1561	23.4			
Wrist/Hand/Finger	1235	18.5			
<b>Lower extremity</b>	<b>9265</b>	<b>62.8</b>	<b>14</b>	<b>4.3</b>	<b>0.2</b>
Pelvic	213	2.3	9	64.3	4.2
Hip	827	8.9			
Upper leg/Thigh	440	4.7	5	35.7	1.1
Knee	2925	31.6			
Lower leg/Ankle	2572	27.8			
Foot/Toes	590	6.4			
<b>External</b>	<b>2179</b>	<b>14.8</b>	<b>3</b>	<b>0.9</b>	<b>0.1</b>



Among them, 152 (1.0%) were fatally injured. The number of riders severely injured (i.e. with at least one injury with a severity score greater than or equal to 4) was 328 (2.2%). Each victim could have more than one body region affected and could have more than one injury to a specific injured body region. Multiple injuries to the same body region are counted only once in the following tables.

### Injury patterns

Among all the injured riders, lower extremity injuries (62.8%) and upper extremity injuries (45.3%) were the most common injuries (see table 1). Head injuries occurred in 11.1% of the helmeted riders, which were severe in 9.0% of the cases. Regardless of injury severity, 11.4% of the riders who sustained head injuries suffer from cranial or intracranial injuries and 81.0% had a loss of consciousness.

Ten percent of the riders sustained chest injuries. Chest injuries tended to be severe in 11.1% of the cases. Abdominal injuries affected 5.4% of the riders, which were severe in 5.6% of the cases. A substantial proportion of riders sustained spinal injuries (8.5%). Among the riders sustaining a spinal injury, cervical spine was the most commonly injured region (70.0%). The lumbar spine and the thoracic spine were injured in 22.5% and 11.9% of the riders sustaining a spinal injury.

Among the 328 severely injured riders, half of the riders sustained severe injuries to the chest (see table 2). Among these riders, the lungs were the most frequent intrathoracic organ severely injured including lung contusions (33.5%) and lung lacerations (5.5%). Rib fractures occurred in 18.9% and 29.9% of the riders sustained hemothorax or pneumothorax. Head was the second leading body region severely affected. Among riders who suffered from severe head injuries, 54.4% suffer from cerebral hematoma (extradural, intracerebral or subdural), 15.6% from massive destruction or penetrating injuries, 23.8% from cerebral oedemas and 14.3% from intracranial hemorrhage.

A sizeable proportion of severely injured riders sustained severe abdominal or spinal injuries (13.7% and 9.8% respectively). Among the riders with severe abdominal injuries, spleen and liver were the most frequently abdominal organs severely injured. Among riders who suffer from severe spinal injuries, more than half sustained severe injuries in the thoracic region (53.1%) and severe cervical spine injuries occurred in 43.8% of the cases. Severe lower extremity injuries were pelvic deformity or displacement or amputations. Three riders sustained second/third degree burns covering over 30% of the body.

**Table 2.**  
**Nature of severe injuries among the 328 helmeted motorized two-wheelers severely injured, Rhone Trauma registry, 1996-2003**

AIS4+ N=328		
Injury sustained	No. of Riders	%
<b>Head</b>	<b>147</b>	<b>44.8</b>
Massive destruction/penetrating injuries	23	15.6
Brain stem injury	9	6.1
Cerebellum injury	2	1.4
Cerebral contusion	1	0.7
Diffuse axoma injury	13	8.8
Extradural hematoma	13	8.8
Intracerebral hematoma	50	34.0
Subdural hematoma	17	11.6
Cerebral Tumefaction	1	0.7
Cerebral oedema	35	23.8
Intracranial hemorrhage	21	14.3
Fracture skull	17	11.6
Loss of consciousness	8	5.4
<b>Face</b>	<b>8</b>	<b>2.4</b>
<b>Neck</b>	<b>2</b>	<b>0.6</b>
<b>Chest injuries</b>	<b>164</b>	<b>50.0</b>
Crushing injury	17	10.4
Rupture of thoracic aorta	17	10.4
Myocardial injuries	1	0.6
Lung contusion	55	33.5
Lung lacerations	9	5.5
Hemo/pneumothorax	49	29.9
Rib fractures	31	18.9
<b>Abdominal injuries</b>	<b>45</b>	<b>13.7</b>
Bladder injuries	2	4.4
Intestinal injuries	1	2.2
Kidney laceration	6	13.3
Liver lacerations	13	28.9
Spleen injuries	25	55.6
Stomach lacerations	1	2.2
<b>Spinal injuries</b>	<b>32</b>	<b>9.8</b>
Cervical	14	43.8
Thoracic	17	53.1
Lumbar	1	3.1
<b>Lower extremity injuries</b>	<b>14</b>	<b>4.3</b>
Pelvic injuries	9	64.3
Upper leg/thigh	5	35.7
<b>External injuries</b>	<b>3</b>	<b>0.9</b>

### Crash features

Successful record-linkage has led to 3727 helmeted victims identified as common to police and Registry sources with complete injury coding. Police reports were available for 25.3% of injury crashes which accounted for 90.1% of total fatalities and 76.2% of severely injured riders recorded in the Rhone Trauma Registry.

Of these linked victims, 250 (6.7%) riders suffer from at least one severe injury, among which 137 were fatally injured (3.7%). Motorcyclists accounted for 62.4% of the helmeted injured riders. Most of the injured riders were involved in crashes that occurred in urban area (81.6%) but 33.6% of severely injured riders were the result of crashes in rural area. The majority of the crashes happened on minor road or streets (58.3%), while 34.5% occurred on main road and secondary highway and 4.2% on motorways. However, crashes on main roads and secondary roads accounted for more than half of the severely injured riders (52.8%). Most crashes happened on a weekday (74.6%) and during daylight hours (88.9%). Among severely injured riders, 20% of the riders were involved in a crash at night. The most common injury crash type was collision with at least one another motorized

vehicle, which accounted for 84.9% of the victims. Collision with car accounted for 71.7% of total victims. Collisions with pedestrians or bicyclists, another TWMV or trucks accounted respectively for 2.1%, 1.9% and 2.0% of the crashes.

Overall, single-vehicle crashes accounted for 13.0% of total victims, of which 7.8% with a fixed object (see table 3). In 20.6% of the cases, single vehicle crashes with a fixed object resulted in severe injuries. Among the group of severely injured riders, 24.0% of the riders had single vehicle crash with a fixed object. Head-on collisions between the TWMV and another motorized vehicle were the most frequent collision type, involving 37.1% of the riders. This kind of collision accounted for 26.8% of the severely injured riders.

**Table 3.**  
**Collision type according to vehicle type among the selected 3727 helmeted riders identified as common to police and Registry sources between 1996 and 2003**

	Moped riders N=1402		Motorcycle riders N=2325		Total N=3727	
	No. of riders	%	No. of riders	%	No. of riders	%
Single vehicle - no object hit	44	3.1	150	6.5	194	5.2
Single vehicle – fixed object hit	79	5.6	212	9.1	291	7.8
Collision with pedestrians/bicyclists	39	2.8	41	1.8	80	2.1
Head-on collision	606	43.2	777	33.4	1383	37.1
Front TWMV to rear of a motorized vehicle	198	14.1	336	14.5	534	14.3
Front TWMV to side of a motorized vehicle	133	9.5	275	11.8	408	10.9
Rear-end collision	55	3.9	63	2.7	118	3.2
Broadside collision	66	4.7	64	2.8	130	3.5
Multiple/other	182	13.0	407	17.5	589	15.8

The type of collision was different between moped and motorcycle riders (p-value  $\chi^2 < 0.05$ ). Head-on collisions accounted for 43.2% of the moped crashes and 33.4% of the motorcycle crashes. The percentage of motorcycle riders involved in single vehicle crashes was higher than the one of moped riders. Among motorcycle riders, 9.1% were the result of single vehicle crashes with a fixed object. In contrast, this crash type accounted for 5.6% of injured moped riders.

When we looked at the distribution of the injured body regions in relation to collision type, it appeared that, for a given collision type, the proportion of riders injured in each body region was approximately the same as the collision type's share of total accidents (see table 4). Therefore, it was difficult from these results to single out which particular body region is injured in a specific collision type. On the whole, more than 30% of injuries of each body region are the result of head-on collisions.

Overall, there were significant differences seen in the proportion of riders sustaining head, facial, chest, abdominal, spinal, upper and lower extremity

injuries according to collision type (p-value  $\chi^2 < 0.05$ ) (see table 4). A high proportion of head, facial, chest, abdominal and spinal injuries occurred in single vehicle crashes with a fixed object hit. Collision with pedestrians or bicyclists accounted for 4.0% of facial injuries whereas this crash type occurred in 2.1% of the cases. Collision where the front of the TWMV struck the side of another motorized vehicle accounted for a high percentage of upper extremity injuries (13.2%). Most of lower extremity injuries (40.9%) were observed in head-on collision.

When we looked at the distribution of the injured body regions in relation to vehicle type, it appeared that the proportion of chest, abdominal, spinal and upper extremity injuries was statistically greater among motorcycle riders than among moped riders (p-value  $\chi^2 < 0.05$ ) (see table 5). On the contrary, the percentage of facial injuries was higher among moped riders than motorcycle riders. There was no difference seen in the proportion of riders sustaining head injuries according to vehicle type. When we estimated the risk of being injured in each body region, logistic regression results

**Table 4.**

**Body region injured in relation to collision type among the selected 3727 helmeted riders identified as common to police and Registry sources. Percentages were defined as the number of victims of a given collision type suffering from injury in a given body region among the total number of victims affected in the given body region.**

Collision type	% of total N=3727	Body Region								
		Head N=721	Face N=371	Neck N=176	Chest N=578	Abdomen N=358	Spine N=447	Upper extremity N=1674	Lower extremity N=2602	External N=518
Single vehicle - no object hit	5.2	5.8	3.8	5.7	5.4	4.5	5.6	6.0	4.3	6.4
Single vehicle - fixed object hit	7.8	13.2	11.1	6.3	13.8	12.8	12.8	8.4	6.9	7.9
Collision with pedestrians/bicyclists	2.1	2.1	4.6	4.0	1.6	2.8	2.0	2.3	1.8	2.3
Head-on collision	37.1	32.5	32.3	33.5	33.6	35.8	30.2	34.3	40.9	36.7
Front TWMV to rear of a motorized vehicle	14.3	11.1	11.3	17.0	13.8	14.2	13.9	15.0	13.1	15.8
Front TWMV to side of a motorized vehicle	10.9	11.5	13.2	14.8	11.2	10.3	11.9	13.4	9.9	10.8
Rear-end collision	3.2	3.1	3.0	2.8	1.6	3.6	3.8	2.2	3.2	3.1
Broadside collision	3.5	4.2	3.5	2.3	1.9	1.4	3.4	2.8	3.9	2.9
Multiple/other	15.8	16.6	17.3	13.6	17.1	14.5	16.6	15.7	16.1	14.1

**Table 5.**

**Body region injured in relation to vehicle type among the selected 3727 helmeted riders identified as common to police and Registry sources. Percentages were defined as the number of victims suffering from injury in a given body region among the total number of victims of each vehicle type.**

Collision type	% of total N=3727	Body Region								
		Head N=721	Face N=371	Neck N=176	Chest N=578	Abdomen N=358	Spine N=447	Upper extremity N=1674	Lower extremity N=2602	External N=518
Moped riders	37.6	19.0	13.3	4.8	10.5	7.7	9.7	41.4	70.0	14.6
Motorcycle riders	62.4	19.6	8.0	4.7	18.5	10.8	13.4	47.1	69.7	13.5

showed that the risks of head, facial, chest and abdominal injury were significantly greater for riders involved in single vehicle crashes with a fixed object hit than for riders involved in single vehicle crashes with no object hit (see table 6). Riders involved in collisions where the front of the TWMV struck the rear of another motorized vehicle were less likely to sustain a head injury. Riders involved in rear-end collisions had a significantly lower risk of chest injury. The risk of facial injuries was significantly higher for riders involved in a collision against a pedestrian or a bicyclist. Riders involved in collisions where the front of the TWMV struck the side of another motorized vehicle were more likely to sustain an upper extremity injury. The risk of lower extremity

injury for riders involved in head-on, rear-end, broadside and multiple collisions were significantly greater than the risk for riders involved in single vehicle crashes with no object hit (see table 6). The highest risk was observed for broadside collision. Logistic regression results showed that the risks of chest (OR=1.94 95%CI=1.59, 2.37), abdominal (OR=1.44 95%CI=1.14, 1.83), spinal (OR=1.44 95%CI=1.16, 1.78) and upper extremity injury (OR=1.26 95%CI=1.10, 1.44) were significantly greater for motorcycle riders than moped riders. There was no significant difference in the risk of head, lower extremity and external injury according to vehicle type. The risk of facial injury was lower for motorcycle riders than moped riders (OR=0.57 95%CI=0.46, 0.70).

**Table 6.**  
**Risk of being injured in each body region associated to collision type, crude odds ratios and the corresponding 95% confidence intervals**

	Head	Face	Chest	Abdomen
Single vehicle - no object hit	1.00	1.00	1.00	1.00
Single vehicle - fixed object hit	1.75(1.15,2.67)	2.11(1.12,3.98)	1.99(1.26,3.17)	2.09(1.15,3.81)
Collision with pedestrians/bicyclists	0.84(0.43,1.61)	3.47(1.62,7.45)	0.67(0.30,1.47)	1.59(0.69,3.67)
Head-on collision	0.74(0.51,1.07)	1.22(0.69,2.17)	0.86(0.57,1.30)	1.14(0.66,1.95)
Front TWMV to rear of a motorized vehicle	0.64(0.42,0.97)	1.10(0.59,2.06)	0.93(0.59,1.46)	1.18(0.65,2.11)
Front TWMV to side of a motorized vehicle	0.92(0.61,1.40)	1.76(0.94,3.26)	1.00(0.63,1.59)	1.11(0.60,2.05)
Rear-end collision	0.83(0.47,1.48)	1.32(0.58,3.02)	0.43(0.20,0.95)	1.38(0.64,2.98)
Broadside collision	1.09(0.64,1.85)	1.43(0.65,3.15)	0.49(0.24,1.01)	0.45(0.16,1.25)
Multiple/other	0.93(0.63,1.38)	1.57(0.86,2.86)	1.06(0.68,1.65)	1.08(0.60,1.93)

	Spine	Upper Extremity	Lower Extremity
Single vehicle - no object hit	1.00	1.00	1.00
Single vehicle - fixed object hit	1.65(0.99,2.74)	0.87(0.61,1.25)	1.17(0.81,1.69)
Collision with pedestrians/bicyclists	0.86(0.38,1.93)	0.89(0.53,1.51)	1.04(0.62,1.77)
Head-on collision	0.73(0.46,1.15)	0.67(0.49,0.90)	2.43(1.78,3.32)
Front TWMV to rear of a motorized vehicle	0.89(0.54,1.46)	0.83(0.60,1.16)	1.29(0.93,1.81)
Front TWMV to side of a motorized vehicle	1.01(0.61,1.68)	1.14(0.81,1.61)	1.26(0.89,1.78)
Rear-end collision	1.14(0.59,2.21)	0.41(0.26,0.67)	1.67(1.03,2.71)
Broadside collision	0.88(0.45, 1.75)	0.53(0.34,0.84)	2.67(1.61,4.42)
Multiple/other	0.97(0.60, 1.58)	0.76(0.55,1.05)	1.79(1.28,2.50)

## DISCUSSION

This study was based on an eight-year period and was conducted on a large number of injured riders. The first part of the analysis based on the medical records makes it possible to quantify injuries among 14749 helmeted motorized two-wheelers. It provided information on the body regions frequently and severely injured. Whatever the injury severity extremity injuries were the most common injuries. Head and chest injuries affected ten percent of helmeted riders.

When we looked at severe injuries, we identified chest as the most affected body region for severely injured helmeted riders, as it was shown elsewhere (Ankarath et al. 2002; Kraus et al. 2002). Despite helmet use, a high percentage of injured riders suffer from severe head injuries, which is in agreement with previous findings (Ankarath et al. 2002; Kraus et al. 2002). A substantial proportion of severely injured riders sustained life-threatening injuries to the abdomen and to the spine. Spinal injuries are known to lead to a significant functional impairment, long-term disability and morbidity (Daffner et al. 1987; Gadegebeku et al. 2006; Robertson et al. 2002b; Shrosbree 1978). Previous studies identified the thoracic spine as the most commonly injured body region in motorized two-wheelers (Robertson et al. 2002a; Robertson et al.

2002b). This location is though to occur as a result of hyper flexion of the spine on impact with objects (Drysdale et al. 1975). In our dataset, cervical spinal injury predominated but more than half of the severe spinal injuries sustained by those severely injured were in the thoracic region. A substantial proportion of severe spinal injuries were also to cervical spine as reported in other studies (Ankarath et al. 2002).

We aimed to provide information on the injured body region in relation to vehicle and crash type. This part of the study was conducted on the injured riders identified as common to the Registry and the police file and is not a representative sample of all injured riders. As the degree of being reported by the police varies depending on injury severity (Amoros et al. 2006), crashes resulting in severely injured riders have a higher probability of being reported by the Police than crashes resulting in slightly injured riders. The selected sample of riders involved in crashes identified by both sources represents more seriously injured riders than the overall population of injured riders. The ideal study population for this investigation would include all riders, regardless of injury severity. Therefore, results should be taken with caution.

It appeared that, for a given collision type, the proportion of injured riders in each body region was approximately the same as the collision type's share

of total accidents. We did not single out which particular body region is injured in a specific collision type. Whatever the body region affected, head-on collisions, which is the most frequent collision type, accounted for a third of injured riders. As it has been shown elsewhere (Chang and Yeh 2006; Lin et al. 2003; Lin et al. 2001), our results showed that single-vehicle crashes with a fixed object accounted for a sizeable proportion of injured riders in each body region. This was particularly the case of injuries to the head, chest abdomen and spine, which tended to be severe.

Among single vehicle crashes, there were some differences between crashes with a fixed object and crashes with no object. The risks of head, facial, chest and abdominal injury were significantly greater for riders involved in single vehicle crashes with a fixed object hit than for riders involved in single vehicle crashes with no object hit. Head-on crashes with a fixed object could explain these results.

Compared to helmeted riders involved in single vehicle crashes with no object hit, the risk of facial injury was significantly higher for riders involved in a collision with a pedestrian or a bicyclist. Riders involved in collisions between the front of the TWMV and the side of another vehicle were more likely to sustain upper extremity injuries. The risk of lower extremity injury for riders involved in head-on, rear-end, broadside and multiple collisions were significantly greater than the risk for riders involved in single vehicle crashes with no object hit. The highest risk was observed for broadside collisions as it has been shown elsewhere (Peek et al. 1994). Riders involved in collisions where a motorized vehicle hit the rear of the TWMV had a significantly lower risk of chest injury.

The risk of chest, abdominal, spinal and upper extremity injury were significantly higher for motorcyclists than moped riders. The differences between moped and motorcycle crashes (speed, energy involvement, crash location) explain these results. In our study, we didn't take into account crash dynamics because it wasn't possible to estimate relevant measures such as Delta V or Equivalent Energy Speed. A published study focused on the injury pattern of moped and motorcycle crashes to see if a difference exists between the two (Matzsch and Karlsson 1986). Moped crashes were similar to motorcycle crashes in their injury patterns. They differ in degree of severity, due to the lesser speed and energy involved in moped accidents (Matzsch and Karlsson 1986).

Contrary to motorcycle riders, moped riders had significantly more risk of facial injury. We could suppose that the choice of helmet type could have an influence on the incidence of facial injury: the increase in facial injury risk among mopeds riders could be explained by the lower proportion of

moped riders using a full-face helmet compared to motorcyclists.

Our results give a good insight into injuries sustained by riders in motorized two-wheeler crashes. Despite helmet use, a sizeable proportion of helmeted riders suffer head injuries, even severe ones and in many cases, there remains a high degree of impairment in the long-term outcome (Gadegbeku et al. 2006). First, we should encourage the future studies to get the information on helmet type in order to specify the level of protection of each helmet type. We should also support research on better helmet design (Richter et al. 2001). Second, our results indicated that the attention given to head protection shouldn't ignore the vulnerability of other parts of the body. In fact, prevention strategies should also provide better protection for vital organs in the chest, abdomen, and spine, as it has been emphasized in previous studies (Ankarath et al. 2002; Kraus et al. 2002). The use of equipment such as "back protectors" or "airbag" has been suggested to protect against chest and spinal injuries (Robertson et al. 2002a; Robertson et al. 2002b). This equipment may prevent injuries but at present the effect of such clothing on injury reduction has not been evaluated. Future studies should get the information on the use of such equipment by the riders and might measure the explicit protective effect of such equipment. The use of protective clothing may prevent some lower extremity injuries in motorcycle crashes like soft-tissue injuries (Kraus et al. 2002; Peek et al. 1994).

The use of safety devices is a necessary but not a sufficient condition for preventing motorized two-wheeler injuries. Despite the use of safety devices, motorized two-wheeler crashes could result in injuries that cause a permanent disability and impairment.

As factors such as being on rural roads, collisions with a heavier object, darkness, might increase the severity of injuries (Chang and Yeh 2006; Lin et al. 2003), the improvement of road infrastructure is needed to reduce the occurrence of motorized two-wheeler crashes. Public awareness campaigns on the vulnerability of motorized two-wheelers and their crash risks could contribute to a reduction in road crashes. Finally, as driver behaviour or human factors contribute to crash severity especially in single vehicle crashes, policies should be developed to improve driver experience (familiarity with a specific vehicle, licensing process...) as proposed by several studies (Chang and Yeh 2006; Harrison 1997; Mullin et al. 2000).

## ACKNOWLEDGEMENTS

We wish to thank the following people for having participated in the data collection and data entry, in the framework of the Association for the Registry of road traffic casualties in the Rhône (ARVAC, president YN Martin) and in the framework of INRETS-UMRESTTE (B. Laumon and A. Ndiaye): Ait Idir T, Ait Si Selmi T, Alloatti D, Amoros E, Andriolat M, Artru F, Asencio Y, Assossou I, Auzaneau F, Bagès-Limoges F, Bagou G, Balogh C, Banssillon G, Banssillon V, Barnier N, Barth X, Basset M, Bec JF, Bejui J, Bel JC, Bérard E, Bérard J, Bernard JC, Berthet N, Bertrand JC, Besson L, Biot B, Biot V, Blanc C, Blanchard J, Bœuf C, Boisson D, Bonjean M, Bost J, Bouchedor C, Bouletreau P, Boyer V, Breda Y, Brilland R, Bussery S, Cabet N, Caillot JL, Cannamela A, Caregnato B, Carre M, Catala Y, Chagnon PY, Chambost M, Chantran C, Chardon P, Charnay P, Chatelain P, Chattard S, Chavane H, Chazot G, Chettouane I, Chevreton N, Chevillon E, Chevillon S, Chiron M, Chotel P, Cochard P, Combe C, Contamin B, Coppard E, Cot T, Crettenet Z, Cristini A, Dal Gobbo B, De Angelis MP, Decourt L, Delfosse A, Demazière J, Deruty R, Desjardins G, Devaux J, Dohin B, Emonet A, Escarment J, Eyssette M, Fallavier L, Fanton L, Felten D, Feuglet P, Fifis N, Figura J, Fisher G, Fischer LP, Floccard B, Floret D, Fournier G, Fraisse P, Fredenucci JF, Freidel M, Fuster P, Gadegbeku B, Galin L, Gaillard P, Gallon M, Garnier N, Garzanti A, Gausorgues P, Gautheron V, Genevriev M, Gibaud F, Gillet Y, Goubsky A, Granger M, Grattard P, Gueniaud PY, Guenot C, Guérin AC, Guignand M, Haddak M, Hamel D, Heckel T, Herzberg G, Jacquemard C, Javouhey E, Joffre T, Kohler R, Lablanche C, Lafont S, Lagier C, Lapierre B, Laplace MC, La Rosa C, Laurent R, Lebel M, Leblay G, Le-Xuan I, Lieutaud T, Lille R, Linné M, Lucas R, Machin B, Maello E, Malicier D, Mangola B, Marduel YN, Marie-Catherine M, Martin JL, Martinand G, Marty F, Mazouzi S, Messikh C, Meyer F, Meyrand S, Molard S, Morel-Chevillet E, Mioulet E, Minjaud F, Mollet C, Monnet J, Moyon B, Neidhart JP, Ngandu E, Ny S, Ould T, Paget P, Paillot JC, Paris D, Patay B, Pauget P, Peillon D, Perrin-Blondeau D, Petit P, Piton JL, Plantier M, Pornon P, Pramayon C, Quelard B, Raquin L, Rezig M, Rigal F, Robert D, Rode G, Romanet JP, Rongieras F, Roset C, Rousson A, Roussouli P, Roux H, Ruhl C, Salamand J, Salord F, Sametzky P, Sayegh K, Sbraire N, Scappaticci N, Schiele P, Schneider M, Simonet C, Sindou M, Soldner R, Soudain M, Stagnara J, Stamm D, Suc B, Taesch MC, Tasseau F, Tell L, Thomas M, Tilhet-Coartet S, Tissot E, Toukou JC, Trifot M, Vallee B, Vallet G, Vancuyck A, Vergnes I, Verney MP, Voiglio EJ, Vourey G, Vuillard J, Westphal M, Willemen L.

This current work is partly included in the framework of the Predit project "PROMOTO" (Protection of the motorcyclists) supported by the French national research agency (ANR).

## REFERENCES

AAAM (Association for the Advancement of Automotive Medicine). The abbreviated injury scale (1990 revision). Des Plaines, IL, USA, 1990.

ONISR. La sécurité routière en France. Bilan de l'année 2004. La Documentation Française, Paris, France, 2005.

Amoros, E., Martin, J.L. and Laumon, B., 2006. Under-reporting of road crash casualties in France. *Accid Anal Prev* 38 (4), 627-635.

Ankarath, S., Giannoudis, P.V., Barlow, I., Bellamy, M.C., Matthews, S.J. and Smith, R.M., 2002. Injury patterns associated with mortality following motorcycle crashes. *Injury* 33 (6), 473-477.

Chang, H.L. and Yeh, T.H., 2006. Risk factors to driver fatalities in single-vehicle crashes: comparisons between non-motorcycle drivers and motorcyclists. *Journal of transportation engineering* 132 (3), 227-236.

Daffner, R.H., Deeb, Z.L. and Rothfus, W.E., 1987. Thoracic fractures and dislocations in motorcyclists. *Skeletal Radiol* 16 (4), 280-284.

Drysdale, W.F., Kraus, J.F., Franti, C.E. and Riggins, R.S., 1975. Injury patterns in motorcycle collisions. *J Trauma* 15 (2), 99-115.

Gadegbeku, B., Ndiaye, A. and Chiron, M., 2006. Séquelles majeures en traumatologie routière, registre du Rhône, 1996-2003. *Bulletin épidémiologique hebdomadaire* 36, 267-272.

Harrison, W.A., 1997. An exploratory investigation of the crash involvement of disqualified drivers and motorcyclists. *Journal of safety research* 28, 213-219.

Kraus, J.F., Peek-Asa, C. and Cryer, H.G., 2002. Incidence, severity, and patterns of intrathoracic and intra-abdominal injuries in motorcycle crashes. *J Trauma* 52 (3), 548-553.

Laumon, B. and Martin, J.L., 2002. Analysis of biases in epidemiological knowledge of road accidents in France. *Rev. Epidemiol. Sante. Publ.* 50 (3), 277-285.

Laumon, B., Martin, J.L., Collet, P., Chiron, M., Verney, M.P., Ndiaye, A. and Vergnes, I., 1997. A french road accident trauma registry: first results. In: *41st Annual Proceedings of the Association for the Advancement of Automotive Medicine*, Orlando, Florida, 127-137

Lin, M.R., Chang, S.H., Huang, W., Hwang, H.F. and Pai, L., 2003. Factors associated with severity of motorcycle injuries among young adult riders. *Ann Emerg Med* 41 (6), 783-791.

Lin, M.R., Hwang, H.F. and Kuo, N.W., 2001. Crash severity, injury patterns, and helmet use in adolescent motorcycle riders. *J Trauma* 50 (1), 24-30.

Matzsch, T. and Karlsson, B., 1986. Moped and motorcycle accidents--similarities and discrepancies. *J Trauma* 26 (6), 538-543.

Mullin, B., Jackson, R., Langley, J. and Norton, R., 2000. Increasing age and experience: are both protective against motorcycle injury? A case-control study. *Inj Prev* 6 (1), 32-35.

Peek-Asa, C. and Kraus, J.F., 1996. Alcohol use, driver, and crash characteristics among injured motorcycle drivers. *J Trauma* 41 (6), 989-993.

Peek, C., Braver, E.R., Shen, H. and Kraus, J.F., 1994. Lower extremity injuries from motorcycle crashes: a common cause of preventable injury. *J Trauma* 37 (3), 358-364.

Quddus, M.A., Noland, R.B. and Chin, H.C., 2002. An analysis of motorcycle injury and vehicle damage severity using ordered probit models. *J Safety Res* 33 (4), 445-462.

Richter, M., Otte, D., Lehmann, U., Chinn, B., Schuller, E., Doyle, D., Sturrock, K. and Krettek, C., 2001. Head injury mechanisms in helmet-protected motorcyclists: prospective multicenter study. *J Trauma* 51 (5), 949-958.

Robertson, A., Branfoot, T., Barlow, I.F. and Giannoudis, P.V., 2002a. Spinal injury patterns resulting from car and motorcycle accidents. *Spine* 27 (24), 2825-2830.

Robertson, A., Giannoudis, P.V., Branfoot, T., Barlow, I., Matthews, S.J. and Smith, R.M., 2002b. Spinal injuries in motorcycle crashes: patterns and outcomes. *J Trauma* 53 (1), 5-8.

Rowland, J., Rivara, F., Salzberg, P., Soderberg, R., Maier, R. and Koepsell, T., 1996. Motorcycle helmet use and injury outcome and hospitalization costs from crashes in Washington State. *Am J Public Health* 86 (1), 41-45.

Sarkar, S., Peek, C. and Kraus, J.F., 1995. Fatal injuries in motorcycle riders according to helmet use. *J Trauma* 38 (2), 242-245.

Shrosbree, R.D., 1978. Spinal cord injuries as a result of motorcycle accidents. *Paraplegia* 16 (1), 102-112.

Zambon, F. and Hasselberg, M., 2006. Factors affecting the severity of injuries among young motorcyclists--a Swedish nationwide cohort study. *Traffic Inj Prev* 7 (2), 143-149.

# STUDY ON IMPROVING TWO-WHEELED VEHICLE CONSPICUITY

**Masanori Motoki**  
**Hiroshi Hashimoto**  
**Masahiro Noguchi**  
**Tamotsu Hirao**

Japan Automobile Research Institute  
Japan

**Makoto Ishiwatari**  
**Susumu Takahashi**

Japan Automobile Manufacturers Association, Inc.  
Japan  
Paper Number 07-0250

## ABSTRACT

This study was conducted to clarify the effects of automatic headlamp on (AHO) and position lamps on improving the conspicuity of two-wheeled vehicles in the daytime and at dawn/dusk. The following two items were covered:

### **(1) Effect of AHO on reducing injury-causing accidents**

The data was taken from 1990 to 2001 on traffic accidents in Japan involving two-wheeled vehicles. Specific accident configurations closely associated with the conspicuity of two-wheeled vehicles (collision while turning right, right-angle collision, head-on collision) were selected and analyzed.

The findings are as follows:

AHO was confirmed to be effective in reducing the number of specific accidents closely associated with the conspicuity of two-wheeled vehicles in the daytime and at dawn/dusk. As the percentage of AHO-equipped vehicles in the total number of two-wheeled vehicles rose from 0% in 1990 to 71% in 2001, it was calculated that AHO's reduction of specific accidents in the daytime and at dawn/dusk amounted to 12,124 cases (16.0%).

### **(2) Effect of AHO and position lamps on improving two-wheeled vehicle conspicuity**

Twelve subjects observed the approach of an oncoming motorcycle followed by a passenger car (30 m behind) with its passing beams on.

Instructions were given to indicate the motorcycle's conspicuity when it arrived at a point 100 m ahead of their eyepoint. Eight motorcycle lighting conditions were observed.

The findings are as follows.

AHO has an improvement effect on two-wheeled vehicle conspicuity in the daytime and at dawn/dusk. To further improve the conspicuity, it is effective to combine amber position lamps with AHO. The effect of position lamps can be increased by optimizing their color, luminous intensity and distance from the headlamp.

## INTRODUCTION

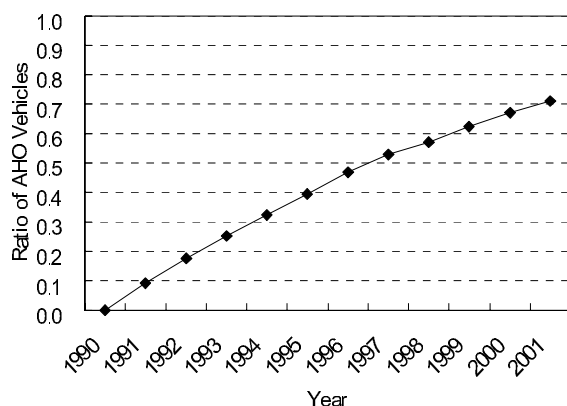
Daytime use of the headlamp and position lamps has been considered as a measure for improving the conspicuity of two-wheeled vehicles.

Starting from 1991, Japan progressively introduced AHO for two-wheeled vehicles.

AHO, whereby the headlamp automatically turns on when the engine is running, was made mandatory in 1997 for new two-wheeled vehicles. By 2001, over 70% of Japan's two-wheeled vehicles were equipped with AHO (See Figure 1).

With the introduction of AHO in European and North American countries, it appeared necessary to evaluate the actual effectiveness of AHO in reducing accidents involving two-wheeled vehicles.





**Figure 1. Ratio of AHO vehicles**

Several European countries (mainly Scandinavian) and Canada have made daytime running lights (DRL) mandatory for four-wheeled vehicles<sup>1)</sup>.

As DRL proposals have been discussed in the United Nation's Working Party on Lighting and Light-Signaling (GRE) and in the European Union<sup>2)3)</sup>, it will be possible to introduce mandatory use of DRL in international regulations in the near future.

Considering the large number of two-wheeled vehicles in Japan (13.2 million in 2005), there are rising concerns that four-wheeled vehicles' DRL will impair the conspicuity of two-wheeled vehicles<sup>4)</sup>.

Therefore, this study was conducted to analyze the number of accidents in situations closely associated with the conspicuity of two-wheeled vehicles (collision while turning right, right-angle collision, head-on collision) according to the time of day (daytime, dawn/dusk, nighttime), in order to verify the effectiveness of AHO in reducing the number of accidents involving two-wheeled vehicles. Furthermore, to cope with the introduction of four-wheeled vehicles' DRL, this study was also conducted to examine the effectiveness of AHO and the position lamps in improving the conspicuity of two-wheeled vehicles followed by a passenger car with passing beams on in the daytime and at dawn/dusk.

## **SURVEY ON THE EFFECT OF TWO-WHEELED VEHICLES' AUTOMATIC HEADLAMP ON FOR TRAFFIC ACCIDENT REDUCTION**

### **Objective**

The objective of this research item was to verify the effectiveness of AHO in reducing accidents. Statistical analysis was conducted on the number of accidents involving two-wheeled vehicles in situations closely associated with the conspicuity of two-wheeled vehicles according to the time of day, in order to determine the relationship between the ratio of AHO vehicles and the accident reduction.

### **Method**

Analysis was conducted on traffic accident data compiled by the Institute for Traffic Accident Research and Data Analysis (ITARDA) according to two-wheeled vehicle class, accident configuration, region, month and hour (every 15 minutes). In this analysis, Japan was divided into nine regions according to longitude, and the injury-causing accidents in each region were analyzed according to month and hour (daytime, 2 hours at dawn + 2 hours at dusk = 4 hours, nighttime).

Specific second-party accident configurations closely associated with the conspicuity of motorcycles were selected (collision while turning right, right-angle collision, head-on collision). These specific second-party accident configurations (hereafter defined as "specific accident") were analyzed.

### **Results**

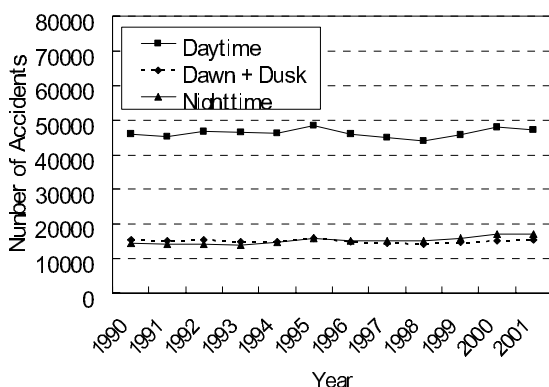
As an indicator of the effectiveness of AHO, the ratio of the number of daytime accidents to the number of nighttime accidents for the specific accident ("day-night accident ratio") was employed.

AHO would be considered effective in reducing accidents if the day-night accident ratio declined while the number of AHO two-wheeled vehicles in use increased. The underlying assumption was that AHO improved the conspicuity of two-wheeled vehicle only in the daytime or at dawn/dusk, but not at night.

**Number of Specific Accidents** – The number of specific accidents was calculated according to the time of day (See Table 1 and Figure 2). The number of daytime specific accidents in 1990 was 45,977. The number of daytime specific accidents in 2001 was 47,157, slightly larger than in 1990 (a difference of 1,180). The number of dawn/dusk specific accidents in 1990 was 15,319. The number of dawn/dusk specific accidents in 2001 was 15,314, nearly equal to that in 1990 (a difference of 5). The number of nighttime specific accidents in 1990 was 14,493. The number of nighttime specific accidents in 2001 was 17,141, larger than in 1990 (a difference of 2,648).

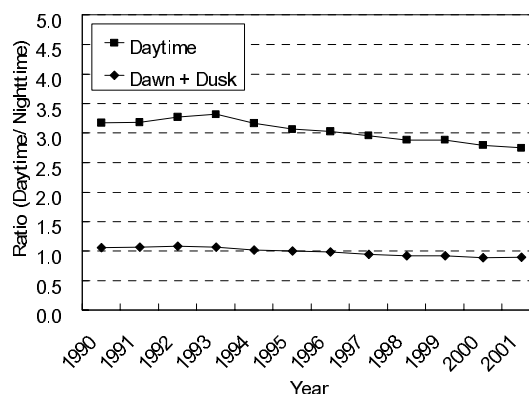
**Table 1.**  
Number of specific accidents

Number of Accidents	Year											
	1990	1991	1992	1993	1994	1995	1996	1997	1998	1999	2000	2001
Daytime	45977	45158	46758	46520	46183	48460	46088	45091	44100	45777	47970	47157
Dawn + Dusk	15319	15146	15451	14959	14898	15893	14968	14535	14107	14603	15151	15314
Nighttime	14493	14207	14290	14016	14614	15831	15219	15243	15271	15857	17168	17141



**Figure 2.** Number of specific accidents

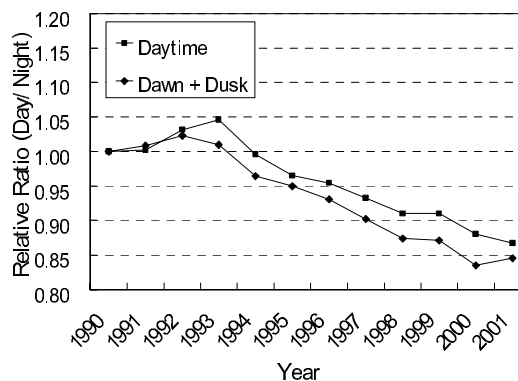
**Day/Night Specific Accident Ratio** – The day-night accident ratio in daytime and at dawn/dusk (number of daytime accidents / number of nighttime accidents or number of dawn/dusk accidents / number of nighttime accidents) declined (See Figure 3). For daytime accidents, the day-night accident ratio was 3.17 in 1990 and 2.75 in 2001. For dawn/dusk accidents, the day-night accident ratio was 1.06 in 1990 and 0.89 in 2001.



**Figure 3.** Ratio of daytime and dawn/dusk accidents to nighttime accidents

**Change in Relative Ratio of Daytime and Dawn/Dusk Accident Ratio** - The day-night accident ratio clearly declined from 1990 to 2000 (See Figure 4). For the daytime specific accidents, the day-night accident ratio in 2001 was 87% of that in 1990, exhibiting a significant difference ( $p < .01$ ) between the 1990 and 2001 rates.

For the dawn/dusk specific accidents, the day-night accident ratio was 85% of the 1990 ratio, also exhibiting a significant difference ( $p < 0.01$ ). So, it was possible to judge that AHO has the effect of reducing specific accidents in the daytime and at dawn/dusk.



**Figure 4.** Change in relative ratio of daytime and dawn/dusk accidents to nighttime accidents (Reference year : 1990)

**Estimation of Effect of AHO on Reduction of Specific Accidents** - To estimate the reduction effect of AHO on specific accidents, two assumptions were adopted:

a) AHO is effective in reducing accidents in the daytime and at dawn/dusk, but not at night;  
 b) The day-night accident ratio for specific accidents between 1990 and 2001 depended on the ratio of AHO-equipped vehicles to the total number of two-wheeled vehicles (the ratio corresponding to the regression line in Figure 5). As the ratio rose from 0% in 1990 to 71% in 2001, it was calculated that AHO's reduction of specific accidents amounted to 8,591 cases in the daytime and 3,533 cases at dawn/dusk for a total of 12,124 cases from 1990 to 2001. Accordingly, it was concluded that AHO is effective in reducing the number of accidents involving two-wheeled vehicles in the daytime and at dawn/dusk.

The calculation procedure was as follows:

(1) Regression line for daytime (Equation 1)

$$y = -0.222x + 1.047 \quad (r = 0.888) \quad (1).$$

(2) Regression line for dawn/dusk (Equation 2)

$$y = -0.275x + 1.045 \quad (r = 0.946) \quad (2).$$

(3) If the day/night ratio corresponds to the regression line, the number of daytime specific accidents in 2001 is as follows: 17,141 (number of nighttime accidents in 2001)  $\times$  0.889 (day/night ratio in 2001:  $y = -0.222 \times 0.71 + 1.047 = 0.889$ )  $\times$  3.172 (day/night ratio in 1990) = 48,336.

If the day/night ratio does not change, the number of daytime specific accidents in 2001 is as follows: 17,141 (number of nighttime accidents in 2001)  $\times$  1.047 (the day/night ratio in 2001:  $y = -0.222 \times 0 + 1.047 = 1.047$ )  $\times$  3.172 (day/night ratio in 1990) = 56,927.

The difference between the two cases is 8591, 15.1% of the total number of specific accidents.

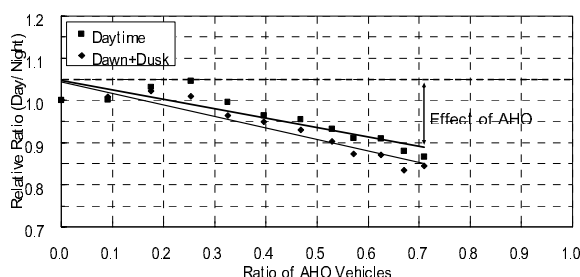
(4) Using the same calculation procedure, if the day/night ratio corresponds to the regression line, the number of dawn/dusk specific accidents in 2001 is 15,400.

If the day/night ratio does not change, the number of dawn/dusk specific accidents in 2001 is 18,933.

The difference between the two cases is 3,533, 18.7% of the total number of specific accidents.

(5) AHO's reduction of specific accidents amounted to 8,591 cases in the daytime and 3,533 cases at dawn/dusk for a total of 12,124 cases (16.0%) in 2001.

AHO's reduction of specific accidents (12,124 cases) was 5.9% of the total number of two-wheeled vehicle accidents (204,645 cases) in 2001.



**Figure 5. Change in relative ratio of daytime and dawn/dusk accidents to nighttime accidents as a function of AHO vehicle' ratio (Reference year: 1990)**

A modified regression line (b = 1.0) is shown in Figure 6.

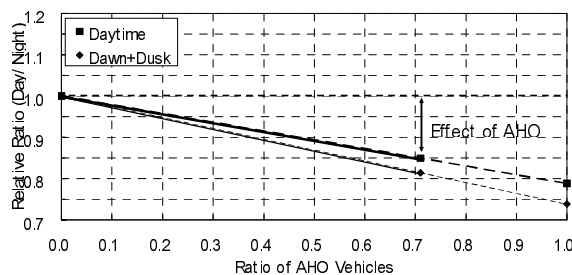
It is possible to easily estimate the accident reduction effect at any ratio of AHO vehicles by using Figure 6.

The regression line for daytime (Equation 3)

$$y = -0.212x + 1.0 \quad (3).$$

The regression line for dawn/dusk (Equation 4)

$$y = -0.262x + 1.0 \quad (4).$$



**Figure 6. Change in relative ratio of daytime and dawn/dusk accidents to nighttime accidents as a function of AHO vehicle' ratio (Reference year: 1990, b=1.0)**

## STUDY ON EFFECTIVENESS OF AHO AND POSITION LAMPS ON TWO-WHEELED VEHICLE CONSPICUITY

### Objective

The objective of this research item was to examine the effectiveness of AHO and the position lamps in improving the conspicuity of two-wheeled vehicles followed by a passenger car with its passing beams on, in the daytime and at dawn/dusk.

### Method

Subjects observed the approach of an oncoming motorcycle followed by a passenger car with its passing beams on, and were instructed to indicate the motorcycle's conspicuity.

**Test Vehicles** - Three motorcycles and a passenger car were employed.

**Lighting Conditions for Test Motorcycle** - The following eight lighting conditions were adopted for test motorcycles, where candela values indicate the maximum luminous intensity of lamps and millimeter values indicate the distance between position lamp and headlamp as measured from the innermost point of the position lamp to the outermost point of the headlamp. Examples of lighting conditions are shown in Figure 7.

- (1) No lamps on
- (2) Headlamp passing beam on
- (3) White position lamps on (30 cd, 75 mm)
- (4) White position lamps on (30 cd, 150 mm)
- (5) Amber position lamps on (30 cd, 75 mm)
- (6) Amber position lamps on (30 cd, 150 mm)
- (7) Amber position lamps on (80 cd, 75 mm)
- (8) Amber position lamps on (80 cd, 150 mm)

Regarding the position lamps used in the test motorcycle, the light source, shape and area are as follows, where area refers to the area of the lens:

- (1) White position lamp 30 cd – incandescent, round (diameter: 60 mm), 28 cm<sup>2</sup>
- (2) Amber position lamp 30 cd – incandescent, round (diameter: 60 mm), 28 cm<sup>2</sup>
- (3) Amber position lamp 80 cd – LED, rectangular (45 mm H, 150 mm W), 68 cm<sup>2</sup>
- (4) Position lamp height from ground – 830 mm
- (5) Headlamp height from ground – 860 mm



(1) No lamps on



(2) Passing beam on (AHO)



(4) White position lamps (30cd, 150mm) on + AHO



(6) Amber position lamps (30cd, 150mm) on + AHO



(8) Amber position lamps (80cd, 150mm) on + AHO

**Figure 7. Lighting conditions of test motorcycles**

### **Lighting Conditions for Test Passenger Car -**

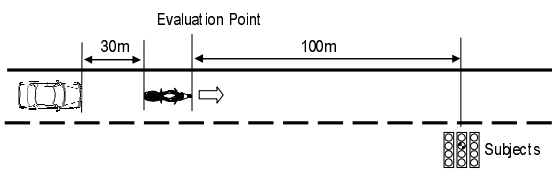
In the case of the test passenger car, the corresponding height of the headlamp was 650 mm from the ground and the separation was 1,230 mm as measured between the centers of the two headlamps.

**Test Course** - A private road with a 3.5m-wide lane on each side was used as the test course.

### **Subject Location and Oncoming Vehicle**

**Operation** - The location of the subjects and the operation setup for the test motorcycle are shown in Figure 8. The subjects were seated on three rows of benches with different seat heights. The eyepoints of the subjects were approximately 1.0 m high from the ground for the front row (nearest to the motorcycle), 1.2 m high for the center row, and 1.4 m high for the back row. The eyepoint location of the subject second from the innermost person in the second row was equivalent to the eyepoint location of the theoretical driver of a passenger car running along the center of the same lane (hereafter "eyepoint").

The test motorcycle was trailed by the test car at a distance of 30 m. Maintaining this condition, both vehicles cruised and passed the eyepoint at a constant speed of 60 km/h.



**Figure 8. Subjects and oncoming motorcycle followed by car**

**Motorcycle Conspicuity Evaluation** - To evaluate the conspicuity of motorcycles, the subjects were instructed to observe an oncoming motorcycle in the opposite lane trailed by a passenger car at a distance of about 30 m. (See Figure 9). The subjects were asked to imagine being a driver trying to make a right turn at an intersection. When the oncoming motorcycle reached the point 100 m ahead of the eyepoint, a signal sounded for 1 second whereupon the subjects recorded how the motorcycle appeared, using the conspicuity evaluation scale.



**Figure 9. Experiment situation (Test motorcycle followed by car)**

**Conspicuity Evaluation Scale** - Motorcycle conspicuity was evaluated on the following scale:

- 1 : Inadequate
- 2 : Somewhat inadequate
- 3 : Just acceptable
- 4 : Somewhat adequate
- 5 : Adequate

A value of 3.0 is the "just acceptable" level, so 3.0 or higher means an acceptable or adequate level of conspicuity.

**Experimental Conditions** - The conspicuity evaluation routine was repeated about 20 times for each of the 8 motorcycle lighting conditions under various levels of sky illuminance. Separate experiments were conducted during daytime, dusk and nighttime hours (sky illuminance level was under 20,000 lx).

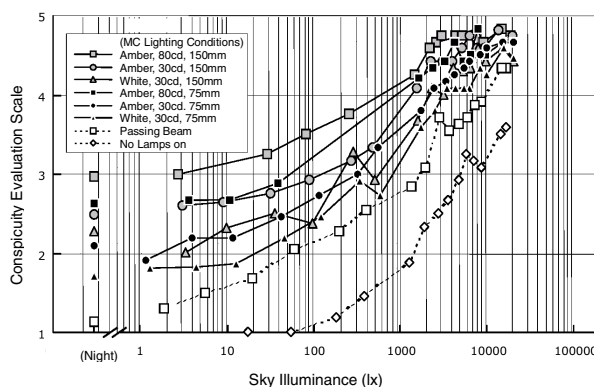
**Subjects** - A total of 12 subjects ranging in age from 27 to 58 (average 43) participated in the experiment. All of them were lamp experts.

### **Results**

The average conspicuity evaluation values rated by the 12 subjects are shown in Figure 10, in relation to sky illuminance. A value of 3.0 is the "just acceptable" level, so 3.0 or higher means an acceptable or adequate level of conspicuity.

The test results are summarized as follows:

- (1) The conspicuity evaluation value declined with a drop in sky illuminance.
  - (2) The conspicuity evaluation value proved to be the lowest when none of the motorcycle lamps were on. The value rose with the headlamp on and the position lamps on, in that order.
  - (3) In the case of position lamps + AHO, the conspicuity evaluation value was higher with amber position lamps compared to white lamps. (For example, when the luminous intensity was 30 cd and the separation was 150 mm, the difference in conspicuity evaluation value was around 0.4).
  - (4) Between position lamps of lower and higher luminous intensity, the more luminous ones gave a higher conspicuity evaluation value compared to the less luminous ones.
  - (5) The conspicuity evaluation value was higher when the position lamps were more widely separated from the headlamp.
  - (6) When the sky illuminance was between 10,000 and 20,000 lx, the headlamp on had a conspicuity improving effect (the difference in conspicuity evaluation value between headlamp on and off was around 0.7). Furthermore, the position lamps had a greater conspicuity improving effect (the difference in conspicuity evaluation value between position lamps + headlamp and no lamps was around 1.2).
  - (7) Under the no lamps condition, the conspicuity evaluation value declined below the acceptable borderline of 3.0 when sky illuminance was less than 5,000 lx. Accordingly, if sky illuminance is less than 5,000 lx (corresponding to 30 minutes before sunset on a clear day), it is preferable to turn on the headlamp in order to obtain adequate conspicuity.
- Under the headlamp condition, the conspicuity evaluation value dropped below 3.0 when sky illuminance was less than 1,000 lx. However, when the position lamps were turned on in addition to the headlamp, conspicuity was improved.
- Accordingly, if sky illuminance is less than 1,000 lx (corresponding to 5 minutes before sunset on a clear day), it is preferable to turn on both the headlamp and position lamps in order to obtain adequate conspicuity.



**Figure 10. Conspicuity evaluation on motorcycle followed by car**

## CONCLUSION

- (1) As AHO was confirmed to be effective in improving the conspicuity of two-wheeled vehicles and reducing the number of accidents involving two-wheeled vehicles, the use of AHO should be introduced in more countries and regions.
- (2) To cope with the introduction of four-wheeled vehicles' DRL, amber position lamps should be combined with AHO for further improvement of two-wheeled vehicle conspicuity.
- (3) To further improve the conspicuity of two-wheeled vehicles, it would be advantageous to re-examine the color of position lamps (amber), their luminous intensity (higher intensity) and their separation distance from the headlamp (longer distance).

## REFERENCES

[1] TRANS/WP.1/2002/12. 2002. "Utilization and Circulation of Daytime Running Lamps", 1-11.

[2] European Commission Directorate-General for Energy and Transport. 2002. "Saving Lives with Daytime Running Lights (DRL), A Consultation Paper", 1-9.

[3] TRANS/WP.29/GRE/56. 2006. "Report of the Working Party on Lighting and Light-Signaling (GRE) on its Fifty-Sixth Session", 9-10.

[4] Motoki, M., Hashimoto, H., Noguchi, M., Hirao, T. 2006. "Study on the Effect of Four-Wheeled Vehicles' Daytime Running Lamps", Journal of Society of Automotive Engineers of Japan, Vol. 60, No. 12, 114-119 (In Japanese with English abstract).

# MARVIN – MODEL FOR ASSESSING RISKS OF ROAD INFRASTRUCTURE

**Peter Saleh**  
**Peter Maurer**  
**Michael Aleksa**  
**Rainer Stütz**

arsenal research – Österreichisches Forschungs-  
und Prüfzentrum Arsenal Ges.m.b.H.  
Austria  
Paper Number 07-0270

## ABSTRACT

The project MARVIN is about assessing the relation between road infrastructure and road accidents. A large amount of data about the Austrian roads was gathered with the RoadSTAR (Road Surface Tester of arsenal research). This data was put into a database associated with accident data. The result was a database of about 12.500 km of road where all the road parameters (skid resistance, cross fall, gradient, texture, roughness, curve radius, etc.) belonging to a certain accident can be retrieved.

One approach is to take a piece of road where accidents happened and to find a very similar section of road with roughly the same parameters. These pieces of roads can be an interesting lead to reduce the number of accidents caused by road conditions. It could be the case that on a certain part of road a lot of accidents happened while on another segment, very similar in road parameters, no accidents happened at all. In this case there can be other parameters (that are not in the database) that influence the road safety such as speed limits or traffic density etc.

MARVIN is also planned as an open platform to integrate more relevant data like traffic flow data or weather data.

MARVIN is a new tool for crash-causes-research, to identify “virtual” road sections with a high crash risk potential or “virtual” hot spots. It is possible to realize route graphs which show all kinds of infrastructure parameters and located accident events. This is a practical tool to audit existing roads as well as planned roads and to develop accident preventive measures in terms of road constructions and road infrastructure.

Regarding to the accident risk of powered-two-wheelers (PTWs) the tendency of a significant influence of the road construction and the quality of the road surface on motorcycle accidents, can be shown in the first results of pilot studies and analysis.

## INTRODUCTION

The goal of the project MARVIN is to find a relation between road infrastructure and road accidents. The data used for this research project are data about surface characteristics and data about the alignment of the Austrian roads which were gathered with the RoadSTAR (Road Surface Tester of arsenal research) and accident data. The basis of MARVIN is a database of about 12.500 km of road where all the relevant road parameters (skid resistance, cross fall, gradient, texture, roughness, curve radius, etc.) belonging to a certain accident can be retrieved.

With MARVIN we strike a new path in crash-causes-research, as “virtual” road sections with a high crash risk potential or “virtual” hot spots can be identified. Another aim of the project is to demonstrate the connection of different parameters for accident sources using mathematical models, the clarification of accident events on similar route sections and develop innovative accident prognoses and derived preventive measures.

## SUBSTANTIVE PAPER

The basic idea of MARVIN is to find accident-causal combinations on the base of combinations of RoadSTAR measurements (Road Surface Tester of arsenal research) with accident data or parameters to explain a dependence of the accident events in connection with road geometry and surface condition parameters. A main point is the development of algorithms to find “similar” road sections and their visualization in geographic information systems.

Among other things, aims of MARVIN are the recognition and description of fundamental connections between road surface parameters and accident risk for certain accident types, a more specific discussion about the issue “risk appreciation of street infrastructure” (with the help of a “virtual” road search and the visual representation as graphs in the road system, potentially dangerous road sections can be determined or planned streets can be simulated) and an objective safety-check by made/planned measures to elevate of the road safety.

The data material supplied by RoadSTAR is unique throughout Europe with regard to quality, resolution and area coverage. This data pool enables arsenal research to carry out exhaustive observations as to the connection between road infrastructure and accidents. Thus the analysis of the causes of an accident don't have to take



individual places of accident or places of accident accumulation as a starting point, but can cover the whole network. Subsequently models for the prediction of accidents are developed from these data.

By the development of RoadSTAR more accurate findings of the road surface conditions can be obtained, thus making a material contribution to traffic safety.

### Information about the RoadSTAR – Road Surface Tester of arsenal research



- ① Measuring wheel incl. braking torque measurement
- ② Pneumatic cylinder
- ③ Wetting unit
- ④ Prewetting system
- ⑤ Gearbox for producing 18% slip
- ⑥ Water tank
- ⑦ Device storage
- ⑧ Drivers cabin - digital data acquisition

The RoadSTAR was developed by arsenal research experts in close cooperation with the Stuttgart Research Institute of Automotive Engineering and Vehicle Engines. The RoadSTAR allows the most important surface properties and road geometry parameters to be measured under normal traffic conditions at measuring speeds between 40 km/h and 120 km/h (standard speed 60 km/h). Measuring runs are additionally recorded digitally on (DV) video tapes. All measured values are tagged with differentially corrected GPS coordinates. The RoadSTAR is mounted on an ÖAF 2-axle truck. Engine power is sufficient to allow the RoadSTAR to measure a road with a skid resistance of  $\mu = 1.0$  and a gradient of 8 % at a speed of 80 km/h with a full water tank holding 6000 litres.

The RoadSTAR allows following important surface properties and road geometry parameters to be measured under normal traffic conditions:

#### Skid Resistance:

- 18% Slip (Standard)
- Temperature of the road surface
- Blocked wheel
- Temperature of the measuring tire
- Antilock Braking System (ABS)

#### Macro-Texture:

- MPD (Mean Profile Depth)
- ETD (Estimated Texture Depth)

#### Transverse Evenness:

- Rut depth (left, right)
- Theoretical waterfilm thickness
- Profile depth (left, right)
- Waterfilm width
- Rut width
- Waterfilm volume
- Rut Volume

#### Roughness:

- IRI (International Roughness Index)
- FFT-Analysis
- RN (Ride Number)
- Longitudinal Profile

#### Road Geometry:

- Curvature
- Height profile
- Crossfall
- Gradient
- dGPS-coordinates

### Visualisation in Geographic Information Systems

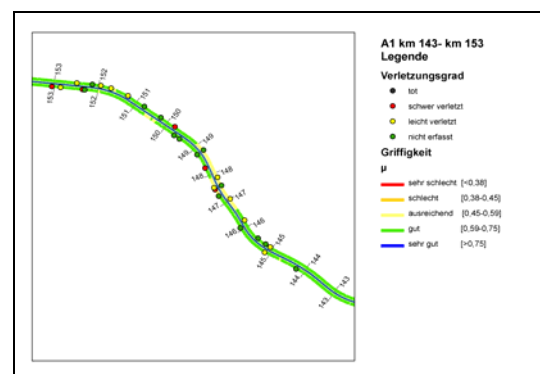


Figure 1. Visualisation, Route graph example 1

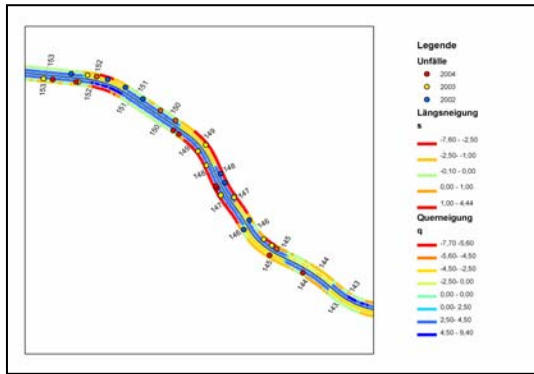


Figure 2. Visualisation, Route graph example 2

The combination of parameters (as shown in route graphs at Figure 1 and Figure 2) enables a timely and economic initiation of the necessary redevelopment measures. The examination of connected data and the comparison with similar points in the residual road network results in the possibility to derive measures for an economic mitigation of existing and (as a preventive measure) potential accident hot spots.

Significant visualisations of crash-causal-combinations on route graphs (automatically generated by measured dGPS-data inclusive inertial navigation gyre) can be done; information on road geometry, road condition and accidents can be presented in different graph-layers.

The traditional approach for accident analysis in Austria is to look at so-called “accident hot spots”. Hot spots are sites where accidents occur most frequently. The positions of these hot spots in Austria are calculated from the accident database. In Austria about a fourth of the car accidents causing personal injury happen on hot spots in the year 2000. Hence about 75% of the accidents are mostly ignored by just researching the accidents happening on these hot spots. It is plausible that groups of similar accident sites exist, of which none is a hot spot yet. Such a group of almost identical sites could be called a “virtual” hot spot, which is not seen as a hot spot by traditional accident research, because it does not identify these sites as similar.

Models for the evaluation of the risk potential of traffic infrastructure (project MARVin) are being developed. The project MARVin engages in the relation of traffic condition and accidents and includes the analysis of the road condition, location and event of the accident. Selective and historic analyses can be conducted thus linking present accident and road condition data. In case of an accident road geometry/road condition can be coordinated with the help of geometric design.

The main step is to take a road section where accidents happened and to find very similar road sections with roughly the same infrastructure-parameters in the whole road network (“Similarity Search”). These sections of roads can be an interesting lead to reduce the number of accidents caused by road conditions. It could be that on one road section a lot of accidents happen while on another piece, very similar in road parameters, no accidents happened at all. In this case there can be other parameters (that are not in the database) that influence the road safety such as speed limits or traffic density etc.

### MARVin for Road Safety

Another important tool of MARVin is to search for “virtual” road sections in the whole road network (Figure 3 and Figure 4). It is possible to create an artificial road (e.g. specific road geometry and road condition-parameters) and to find similar, but existing road sections. This is important for a safety-check of planned roads (Road Safety Audits) and to show potential hazard areas which indicates changes of the planning as an economic accident preventive measure.

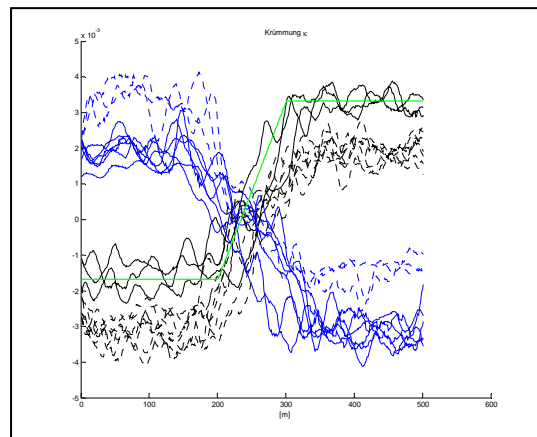


Figure 3. Curvature of a “virtual” road (green)

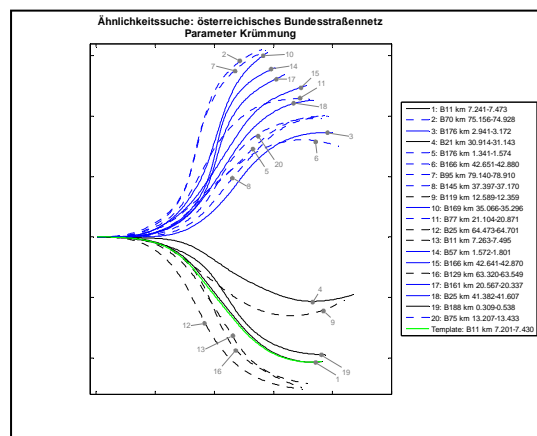
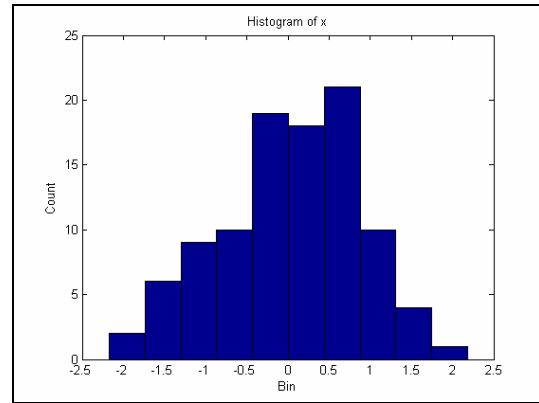


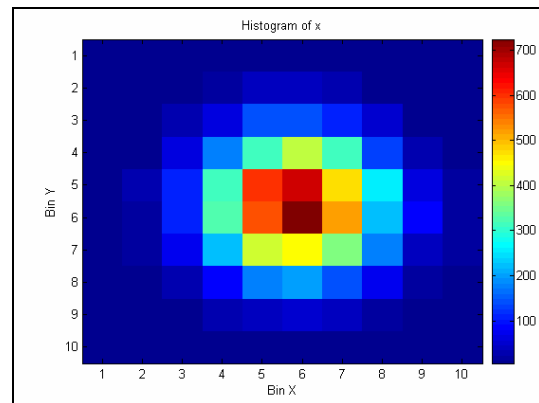
Figure 4. Resulting similar road sections

The problem of the automatic recognition of similar road sections was extensively solved with a method which has his origin in automatic speech recognition, the so called Dynamic Time Warping (DTW). Dynamic Time Warping yields a robust similarity measure for time series with similar shape even if they are out of phase. In general DTW is a method which allows finding an optimal alignment between two given (multivariate) sequences (e.g. time series) with certain restrictions. In our case DTW yields a nonlinear similarity measure of different parameters of a candidate with a given road section (template). In contrast to the methods which were developed in the first project phase (similarity search with Dynamic Time Warping) which always need an existing distance as a start value, new possibilities were examined to implicate the whole amount of the accidents impartially ("unbiased") for dependences. Diagrammatically this is conceivable as follows: the parameters of every accident (discrete, as for example the accident type from the accident report or the road surface type from the RoadSTAR data or continuous real values, like skid resistance or rut depth) are considered as coordinates in a high-dimensional space. Correlations will be remarkable by the different density of the points (= accidents) in certain areas or by the variances. Based on this, methods were searched and were examined to sight the enormous data amount manual-visual (about 40000 personal damage accidents or accident records per year, 12 years approx. 490000 points in 50 or more dimensions) or to analyze purely computer-assisted. This amount in accident data together with the RoadSTAR-road conditions data to be processed parallel, cause an arithmetic expenditure and computing power which should not be underestimated.

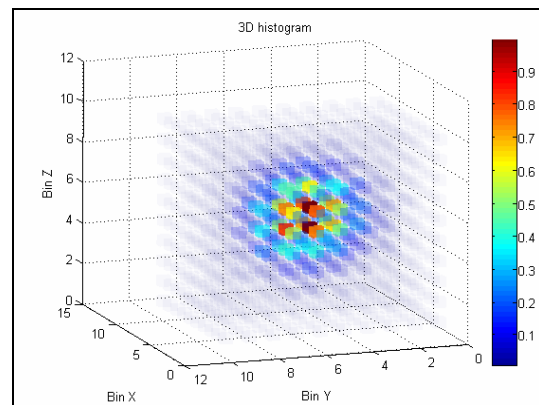
For a manual-visual selection normalized (multidimensional) histograms are provided. Here the samples of the database are represented not as points in the space, but are summarized into classes. The numbers of the class member events are represented for the two-dimensional case with the help of a colour scale.



**Figure 5. Histogram in one dimension**



**Figure 6. Histogram in two dimensions**



**Figure 7. Histogram in three dimensions**

Connections in two dimensions can be shown very well. For the three-dimensional case the applicability is already limited by the covered sight (Figure 5, Figure 6 and Figure 7). For additional dimensions above all discrete dimensions can be represented side by side. However, the use for the recognizability of connections will be more doubtful with increasing number of the represented dimensions and in no case 50 dimensions are representably in this way. That means that this method does make sense, when coarse connections

and the primarily decisive dimensions are identified in a different ways, which can be made completely with statistical methods or by plausible acceptances of known critical combinations (e.g. skid resistance, rain and rut depth).

At the examples shown at the top, connections of RoadSTAR parameters and accidents can be represented very openly; a comparison with evaluations of specific accident types or similar road sections will lead to unambiguous accident-specific dependences of the street parameters. With MARVin it is possible to strike a new path in the crash-causes-research and our goals for the future are written down in the commitment of the European Road Safety Charter, as written below.

### MARVin for Motorcycle Safety

The first practical work with MARVin tools was a road safety check of a typical motorcycle route, to find out correlations between the number of accidents on specific sites and the road infrastructure parameters. The interesting, but not so much surprising result was, that the quality of this road was high (high skid resistance, perfect radii relations and curvature, etc.). All these parameter show, that because of the high quality this road is a magnet for the motorcyclists. Sure, it doesn't mean that a lower quality will make the accident situation better. The significant facts for high risk potential of this road are the number of riders each day and the driven speed. Especially on weekends speed enforcement campaigns can lead to an accident reduction.

Another use example of MARVin was the analysis within the frame of the development of a national directive for motorcycle safety. A detailed all over check of motorcycle accident events on rural roads from 1999 to 2004 and their correlation to curve radii have shown a unique result (Figure 8).

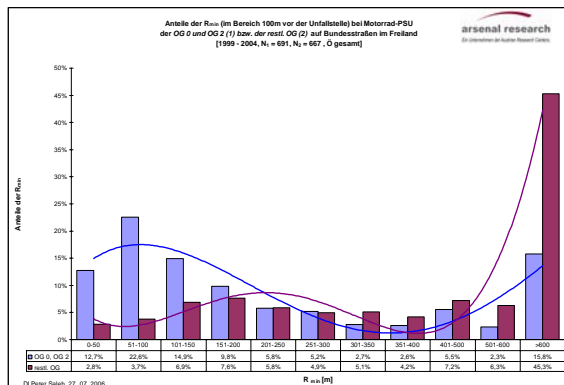


Figure 8. Curve radii and accident types

Specifically abandon accidents mostly occur in small radii between 50 and 150 meters; the maximum ratio of abandon accidents in curves is exactly in the radius 100 m, followed by 110 m.

Specifically detailed analyses of relations of various curve radii (as shown above), the curvature and the changing crossfall in road sections and their influence on PTW accident events are necessary. The so called "Similarity Search", which identifies similar accident events on similar road sections, will also be used within these analyses. Moreover the simulation and search of virtual or existing road sections in the whole road network with a high accident-risk potential are possible.

In a possible PTW-project which is proposed in the 7<sup>th</sup> Framework Programme of the EU, a work package will be the identification of the correlation of radii relations on motorcycle accidents. Specifically double bends and double bends with small straight lanes between the two radii will be analysed in detail.

### European Road Safety Charter



With some 170 highly qualified staff members, arsenal research has established itself as a European research center in the future-oriented fields of mobility and energy. The organization's primary objective is to boost the innovation capabilities of its partners by providing them with applied research and development and by linking regional, national and international innovation systems.

Our experts for road safety and traffic telematics crucially contribute to an early recognition of sources of danger in and on traffic infrastructure strive for innovative solutions and their implementation within cooperative networks and are also available for consultations regarding road safety. That's way it is for us a self-evident fact to sign the European Road Safety Charter with the following commitment:

Our goals are:

- Explanation of so far unexplored accident causalities
- Demonstration of the connection of different parameters for accident sources using mathematical models

- Clarification of accident events on similar route sections
- Accident analysis and crash-causes-research specifically regarding powered two-wheelers
- Innovative accident prognoses and derived preventive measures

We reach these aims by:

- Linkage of the road conditions data with accident data based on the locality of the accident
- Development of suitable mathematical models for the verification of accident causalities
- Implementation of accident-cause-research within Road Safety Inspections and Road Safety Audits
- Specific measures to create awareness in combination with driving education, based on detailed accident statistics and conclusions of accident analyses of motorcycles
- Identification of connections between data on road accidents and traffic infrastructure and development of specific preventive measures

## **CONCLUSIONS**

With the research project MARV in it is possible in different ways and with different analysis to find out significant correlations between road accident events and the quality of the infrastructure. The whole road network and all accidents are included in the analysis.

Now the research has progressed so far that the developed tools can be applied practically and can be tested.

Within the frame of the development of a national directive for motorcycle safety, two projects are treated with MARV in tools.

# USE OF GEOCODED FARS DATA TO ANALYZE FATAL MOTORCYCLE CRASHES

**Kevin Majka**  
**Alan Blatt**  
**Marie Flanigan**  
CUBRC  
United States

**Saverio Pugliese**  
Calspan Corporation  
United States

Paper Number 07-0287

## ABSTRACT

Much work has been done recently to examine the trends, contributing factors and characteristics of the increasing number of fatal motorcycle crashes occurring in the United States. This paper explores two new resources, geocoded FARS data and roadway orthoimagery, to examine the geo-spatial characteristics of U.S. fatal motorcycle crashes.

Using 2001, 2002, 2003, and 2004 FARS crash data (that were previously geocoded by the National Highway Traffic Safety Administration's National Center for Statistics and Analysis), we have characterized the locations in the United States that have had fatal motorcycle crashes. Locations where crashes occurred were identified by using spatial and attribute queries of the NHTSA FARS database after the database was imported into a Geographic Information System. During the period from 2001 through 2004, FARS identifies 14,653 fatal motorcycle crashes. Approximately 91 percent of these crashes (13,329) were successfully geocoded and entered into the analyses. A majority (about 70%) of motorcycle fatalities occur on undivided roadways.

A valuable new approach to the analysis of fatal motorcycle crashes will be described. This approach involves use of high resolution orthoimagery which is now available for some, although not all, roadways. In addition, care must be taken to insure that available imagery displays roadway features at the time of the crash.

This paper provides the first geospatial analysis of fatal U.S. motorcycle crashes using *national geocoded* FARS data coupled with available roadway orthoimagery. Precise crash location, roadway

imagery and FARS crash attributes provide unique opportunities to investigate crash trends, causation factors and potential crash mitigation techniques.

## INTRODUCTION

A variety of studies have recently examined the trends, contributing factors and characteristics of the increasing number of fatal motorcycle crashes occurring in the United States [1,2,3]. In addition, geocoded motor vehicle crash data has specifically been used in some analyses to study the spatial and temporal distribution of crashes [4,5,6,7]. For the most part these geographic studies have been performed with relatively small sets of crashes on local, regional or state levels. In some cases, crash analyses were performed using highway segments distinguished by functional classification (freeway v. non-freeway) and location (urban v. non-urban) [8]. Studies have also been performed that show that design attributes such as number of lanes, curve characteristics, vertical grade, surface type, median type, turning lanes, shoulder width, and lane width, can be statistically related to crash activity [9]. Unfortunately, geocoded databases of roadway design attributes are not universally available, particularly for local roadways. This paper examines whether the analysis of orthoimages can help overcome the lack of availability of geocoded roadway design attributes. Orthoimages are geo-referenced images (prepared from a perspective photograph or other remotely-sensed data) in which displacement of objects due to sensor orientation or terrain relief has been removed. This results in an image with the geometric characteristics of a map and the image qualities of a photograph [10]. These characteristics suggest that orthoimages may provide

a means of obtaining a quantitative view of some of the roadway features of interest to crash researchers.

The current study couples orthoimagery with Fatality Analysis Reporting System (FARS)[11] data which has been newly geocoded. FARS contains information on all fatal crashes that occur each year in the United States (where death occurred within 30 days of the crash). The objective of this study is to investigate the geospatial patterns of fatal motorcycle crashes to determine if newly available analysis tools can be used to gain additional insight into crash causation and potential crash mitigation strategies.

### Statement of the Problem

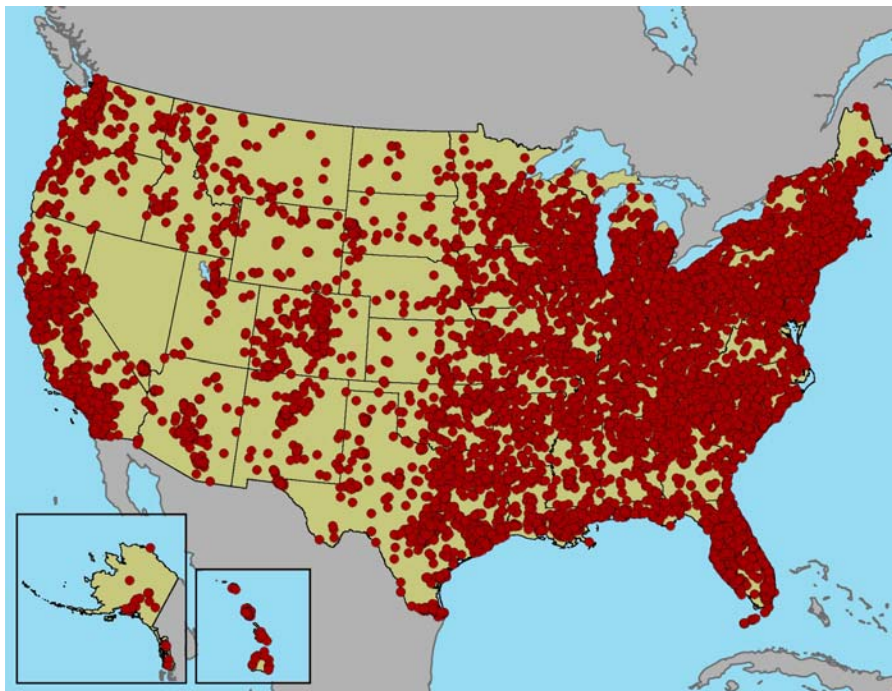
In October 2001, NHTSA published a comprehensive report which indicated that during the 10 year period from 1990 to 1999, 24,495 people died in motorcycle crashes [1]. Of these, 45% (or 10,963 people) died in *single-vehicle* motorcycle crashes. Nearly half of these single vehicle fatalities (5347) occurred in crashes where the motorcycle had to negotiate a curve prior to the crash - and over 90% of these subsequently ended up 'off-roadway'. Of the single-vehicle motorcycle fatalities which occurred while negotiating a curve - over 60% involved speeding as an operator-contributing factor.

Since the decade of the 90s, the situation has not improved. According to a more recent NHTSA report [12], motorcycle fatalities increased by 89% between 1997 (when 2116 fatalities were recorded) and 2004 (when 4008 fatalities occurred). In 2004 motorcycle rider fatalities made up 9.4% of *all* motor vehicle crash fatalities in spite of the fact that motorcycles accounted for only 2% of all registered vehicles and only 0.3% of vehicle-miles-traveled in the U.S. that year. Likewise, NHTSA reported that in 2004, about 76,000 motorcyclists were injured in traffic crashes. This is 13% more than the 67,000 motorcyclists injured in 2003. NHTSA further noted that when comparing fatality rates per vehicle-miles-traveled in 2004, motorcyclists were about 34 times more likely than passenger car occupants to die in a traffic crash (compared to 15 times more likely in 1997).

### Focus of This Paper

This paper will utilize the newly available geocoded FARS data from 2001 through 2004, coupled with orthoimages of selected fatal crash locations to assess whether orthoimages can expand our understanding of motorcycle crash causation.

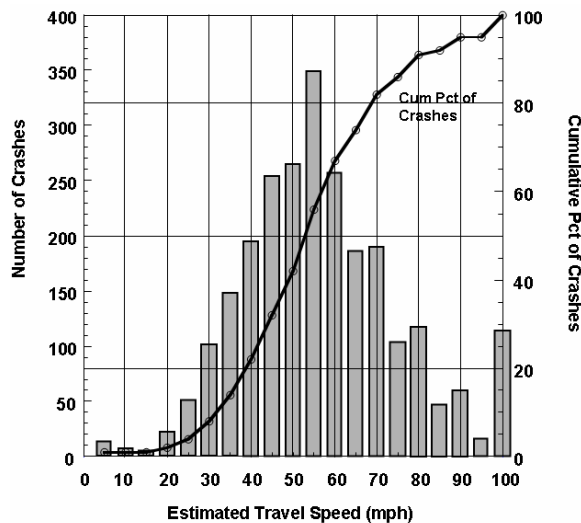
**Figure 1** displays a national map showing the 13,329 fatal motorcycle crash locations which occurred in the US during this four year period.



**Figure 1. Fatal Motorcycle Crash Locations in U.S. from 2001 through 2004.**

To identify a subset of these crashes for which orthoimages could be examined, some initial analyses of the FARS database were performed. First, single-vehicle motorcycle crashes were extracted from FARS and examined in the context of straight vs curved roadway alignment. Of the 6,448 single-vehicle motorcycle crashes in this four year period, roadway alignment was reported for 6415 crashes (or 99.5%) with 43% of these crashes occurring on straight roads and 57% (or 3655 crashes) occurring on curved roads. Moisture conditions were also reported in FARS for about 39% of the 6448 single vehicle motorcycle crashes. It was found that 40% of these crashes took place on straight dry roads while 57% took place on curved dry roads. The remainder (only 3%) indicates that relatively few crashes (with moisture conditions reported) occurred on straight or curved *wet* roads, possibly because fewer trips were made during inclement weather conditions. These combined results suggested that a focus on curved roads might be of particular interest.

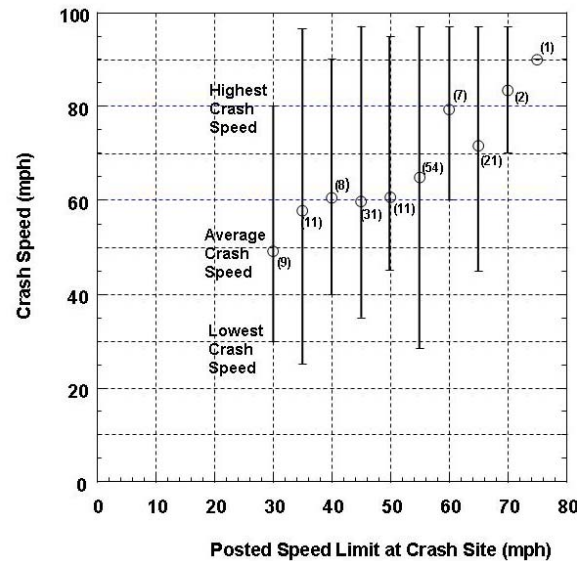
Next, speed was considered. Of the 6,448 single-vehicle crashes, 2500 (or 39%) had estimated travel speeds reported in FARS. **Figure 2** shows the distribution of these single vehicle motorcycle crashes as a function of travel speed with the cumulative percentage (summed over those with reported speeds) also plotted. The estimated travel speed which saw the highest number of crashes over the four year period was 55 mph. It is also apparent that 50% of all of these crashes occurred at speeds in excess of 50 mph.



**Figure 2. Distribution of Single Vehicle Fatal Motorcycle Crashes as a Function of Travel Speed**

The ‘first harmful event’ for single-vehicle motorcycle crashes in FARS was examined next. After overturns (which may or may not be due to roadway characteristics), the greatest number of crashes (562) reported the first harmful event as hitting a guardrail. Of these 562 guardrail crashes, 431 occurred on curved roads during this 4 year period. A further examination of travel speed showed that 163 of the 431 crashes (or 38%) had estimated travel speeds reported in FARS. These speeds ranged from under 25 mph to over 90 mph.

**Figure 3** shows a plot of posted speed limit vs the *average* travel speed reported for single-vehicle (motorcycle) guardrail crashes occurring on curved roadways with posted speed limits between 30 and 75 mph. The number of crashes included in each average is shown in parentheses next to each data point while the vertical lines show the minimum and maximum reported travel speeds included in the average. Note that the largest number of crashes (54) occurred on roadways with a posted speed of 55 mph. For these 54 crashes, the average travel (or crash) speed was 65 mph and the reported travel speeds ranged from 28 to 97 mph. These and the other analyses described above were used to define a manageable (and rational) subset of fatal motorcycle crash locations for which orthoimages were sought. The FARS case selection process is summarized in the Methodology section below.



**Figure 3. Reported Travel/Crash Speed vs Posted Speed Limits for Guardrail Collisions on Curved Roads**



## METHODOLOGY

Beginning in 2001 the National Highway Traffic Safety Administration (NHTSA), which is responsible for the compilation of FARS data, has made an effort to geocode (or give real world latitude and longitude coordinates to) each fatal crash. This geocoding task was undertaken by NHTSA's National Center for Statistical Analysis (NCSA). NCSA has several methods by which to accomplish this task. The first is to use, whenever present, the crash coordinates that are provided by the responding emergency vehicles (which may be contained in the police accident report). The second method is to geocode the locations, which is a process that takes a street address or intersection, matches it to a streets database and geographic file, and returns real world coordinates. The last method is an interactive process by which the crashes are manually digitized and placed in the correct location on a computer map.

### FARS Case Selection

Using 2001, 2002, 2003, and 2004 FARS geocoded crash data for the 50 states and the District of Columbia, we identified 13,329 locations in the United States that had a fatal motorcycle crash in any one of the calendar years 2001, 2002, 2003, or 2004. Further classification of these crashes revealed that 6,448 of those crashes (48.4%) were single-vehicle (motorcycle) crashes. For 562 of these single vehicle crashes, the first harmful event was a collision with a guardrail, with 431 (of 562) characterized as having a curved roadway alignment. Of the 431 single-vehicle (motorcycle) crashes for which collision with a guard rail on a curved roadway was the first harmful event, 54 had a posted speed limit of 55 miles per hour and their actual (estimated) travel speeds were known. These 54 crashes represented the largest number of guardrail crashes on curved roadways at any single posted speed and subsequently became the set of

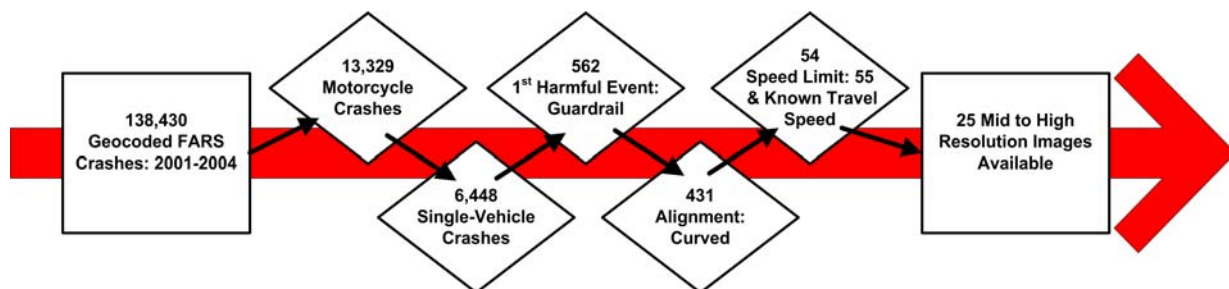
crashes selected for this orthoimagery study. This selection process or 'drill-down method' is illustrated below in **Figure 4**.

In actual practice, these motorcycle crashes were identified by using spatial and attribute queries of the NHTSA FARS database after the database was imported into a Geographic Information System (i.e., ESRI's ArcGIS 9.1 software). The processing of the data included first, selecting those crashes that were defined as 'motorcycle' crashes, which include all makes and models of motorcycles, and exporting this subset of crashes as the population of crashes used in this study for the 2001 through 2004 time frame.

### Analysis of Crashes Using Orthoimagery

The set of 54 crashes to be examined was exported and integrated within Google Earth Plus (4<sup>th</sup> edition) to find those crashes that had commonly available, medium to high resolution orthoimages available for measurement. By importing each crash's latitude and longitude coordinates into Google Earth Plus, a 'visit' of the 54 crash locations was conducted and a determination made as to whether a suitable image was available for each crash location. Of the 54 crashes, 25 images were found to have acceptable resolution so that the roadway radius of curvature could be measured.

For each curve, a nominal distance of 300 meters along the curved roadway was examined on either side of the crash site. A circle was constructed (on the orthoimage) which followed the road curvature over this distance and the circle's radius determined. **Figure 5** illustrates this process. Using the Google Earth measurement tool, the radius of curvature ( $r$ ) was recorded for each crash location. The orthoimages were then introduced into the ArcGIS environment and the measured radii validated using the ArcGIS internal measurement system.



**Figure 4. Flowchart Illustrating FARS Crash Case Selection**



**Figure 5. Orthoimage of Crash Site (on US-14) with Illustration of Approach for Measuring Radius of Curvature.**

## RESULTS

**Table 1** provides a summary of selected attributes (from the FARS database) associated with each of the 25 crashes for which high resolution orthoimages were examined. **Figure 6** and **Figure 7** show representative orthoimages of four fatal, single-vehicle motorcycle crash locations where the rider collided with a guardrail on a curved roadway. **Table 2** summarizes the roadway curvature data extracted from the orthoimages for each of the 25 crashes examined. Data on posted and reported travel speed from FARS is also tabulated. In addition, lateral accelerations were calculated for both the posted and crash reported speeds as follows:

$$\text{Posted Speed Lateral Acceleration} = S_p^2/r$$

where  $S_p$  is the posted speed at the crash location and  $r$  is the roadway radius of curvature. Similarly,

$$\text{Crash Speed Lateral Acceleration} = S_c^2/r$$

where  $S_c$  is the reported crash speed and  $r$  is the roadway radius of curvature.

The results of the lateral acceleration calculations are shown in Figures 8, 9 and 10. **Figure 8** illustrates the relationship between the roadway curvature and the crash lateral acceleration. As expected, the fatal crashes with the highest lateral accelerations tend to occur more frequently on roadways with small radii of curvature (i.e., sharper curves). **Figure 9** provides a crash case-by-case comparison of the crash lateral acceleration and posted speed lateral accelerations. Finally, **Figure 10** shows the number of fatal crashes in our study plotted against the difference between the crash and the posted speed lateral accelerations.

**Table 1. Summary of (Selected) FARS Attribute Data for Crashes Examined in Study**  
Crashes sorted by ID#

ID	Roadway Label	Year	Light Conditions	Roadway Profile	Speed Limit	Travel Speed	PDOF	Alcohol	Age
001	908M	2002	Dark but Lighted	Level	55	97	12	No	32
002	Cole Grade	2004	Daylight	Grade	55	28	12	No	53
003	I-35W	2002	Daylight	Level	55	55	12	No	61
004	I-464	2002	Daylight	Grade	55	97	10	Yes	63
005	I-70	2004	Daylight	Grade	55	65	3	No	33
006	I-74	2002	Daylight	Grade	55	90	Unknown	Yes	27
007	I-75	2002	Daylight	Grade	55	70	2	Yes	35
008	I-95	2003	Daylight	Level	55	97	11	No	29
009	I-95	2003	Dark but Lighted	Level	55	55	12	Yes	30
010	Pala Temecula	2001	Daylight	Grade	55	35	5	No	53
011	Southern St	2003	Dark but Lighted	Level	55	97	9	No	31
012	SR-1	2001	Daylight	Level	55	70	12	Yes	32
013	SR-13	2001	Daylight	Grade	55	30	12	No	70
014	SR-166	2004	Dusk	Level	55	97	3	No	23
015	SR-18	2004	Dark	Grade	55	40	12	Yes	50
016	SR-74	2001	Daylight	Level	55	40	12	No	64
017	SR-89	2003	Daylight	Grade	55	73	3	Yes	54
018	SR-94	2001	Daylight	Grade	55	55	12	No	21
019	Trona Wildrose	2004	Daylight	Grade	55	40	12	No	82
020	US-101	2003	Dark	Grade	55	55	12	No	50
021	US-14	2004	Daylight	Grade	55	88	2	No	22
022	US-169	2003	Dark but Lighted	Grade	55	97	1	No	26
023	US-301	2003	Daylight	Level	55	65	12	No	53
024	US-36	2002	Dusk	Hill crest	55	70	12	Yes	20
025	Wantagh St	2002	Dark	Level	55	97	12	No	20

Note: No adverse weather conditions reported for any crash. Surface conditions for all crashes reported as 'dry' except for US-36 crash (ID=24) which reported surface conditions as 'Other'.

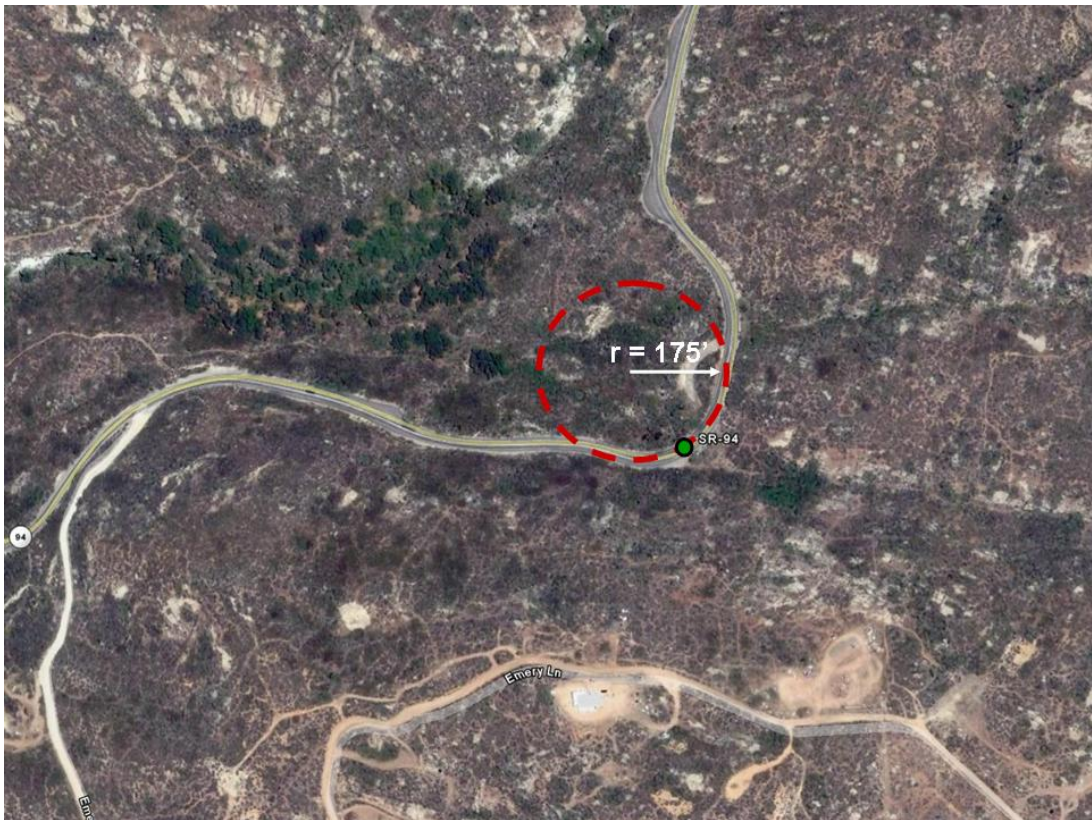


Figure 6 Orthoimages of Curves Where Fatal Crashes Occurred on SR-166 (top) and SR-94 (bottom)



Figure 7 Orthoimages of Curves Where Fatal Crashes Occurred on I-95 (top) and I-464 (bottom)

**Table 2 . Crash Characteristics Derived from Orthoimages**

(Crashes Sorted on Last Column)

Crash ID	Posted speed (mph)	Travel speed (mph)	Travel speed (ft/sec)	Travel speed (m/sec)	Roadway Curve			Values for Crash			Values for Posted Speed			Delta lat accel (crash-posted) (m/sec <sup>2</sup> )
					Roadway Label	Radius (ft)	Radius (m)	lat acc (ft/sec <sup>2</sup> )	lat acc (m/sec <sup>2</sup> )	lat acc (g's)	lat accel (ft/sec <sup>2</sup> )	lat accel (m/sec <sup>2</sup> )	lat accel (g's)	
013	55	30	44	13	SR-13	295	89.9	6.56	2.00	0.20	22.06	6.72	0.69	-4.72
015	55	40	59	18	SR-18	240	73.2	14.34	4.37	0.45	27.11	8.26	0.84	-3.89
002	55	28	41	13	Cole Grade	615	187.5	2.74	0.84	0.09	10.58	3.22	0.33	-2.39
010	55	35	51	16	Pala Temecula	645	196.6	4.09	1.25	0.13	10.09	3.07	0.31	-1.83
016	55	40	59	18	SR-74	1210	368.8	2.84	0.87	0.09	5.38	1.64	0.17	-0.77
019	55	40	59	18	Trona Wildrose	1885	574.5	1.83	0.56	0.06	3.45	1.05	0.11	-0.50
003	55	55	81	25	I-35W	950	289.6	6.85	2.09	0.21	6.85	2.09	0.21	0.00
008	55	55	81	25	I-95	2650	807.7	2.46	0.75	0.08	2.46	0.75	0.08	0.00
018	55	55	81	25	SR-94	175	53.3	37.18	11.33	1.15	37.18	11.33	1.15	0.00
020	55	55	81	25	US-101	1360	414.5	4.78	1.46	0.15	4.78	1.46	0.15	0.00
023	55	65	95	29	US-301	2665	812.3	3.41	1.04	0.11	2.44	0.74	0.08	0.30
005	55	65	95	29	I-70	1690	515.1	5.38	1.64	0.17	3.85	1.17	0.12	0.47
007	55	70	103	31	I-75	1950	594.4	5.41	1.65	0.17	3.34	1.02	0.10	0.63
012	55	70	103	31	SR-1	1865	568.5	5.65	1.72	0.18	3.49	1.06	0.11	0.66
009	55	97	142	43	I-95	4400	1341.1	4.60	1.40	0.14	1.48	0.45	0.05	0.95
024	55	70	103	31	US-36	1120	341.4	9.41	2.87	0.29	5.81	1.77	0.18	1.10
001	55	97	142	43	908M	2400	731.5	8.43	2.57	0.26	2.71	0.83	0.08	1.74
025	55	97	142	43	Wantagh St	1995	608.1	10.15	3.09	0.32	3.26	0.99	0.10	2.10
017	55	73	107	33	SR-89	695	211.8	16.49	5.03	0.51	9.36	2.85	0.29	2.17
006	55	90	132	40	I-74	1450	442.0	12.02	3.66	0.37	4.49	1.37	0.14	2.29
011	55	97	142	43	Southern St	1200	365.8	16.87	5.14	0.52	5.42	1.65	0.17	3.49
022	55	97	142	43	US-169	890	271.3	22.74	6.93	0.71	7.31	2.23	0.23	4.70
014	55	97	142	43	SR-166	840	256.0	24.10	7.34	0.75	7.75	2.36	0.24	4.98
021	55	88	129	39	US-14	600	182.9	27.76	8.46	0.86	10.85	3.31	0.34	5.16
004	55	97	142	43	I-464	165	50.3	122.67	37.39	3.81	39.44	12.02	1.22	25.37

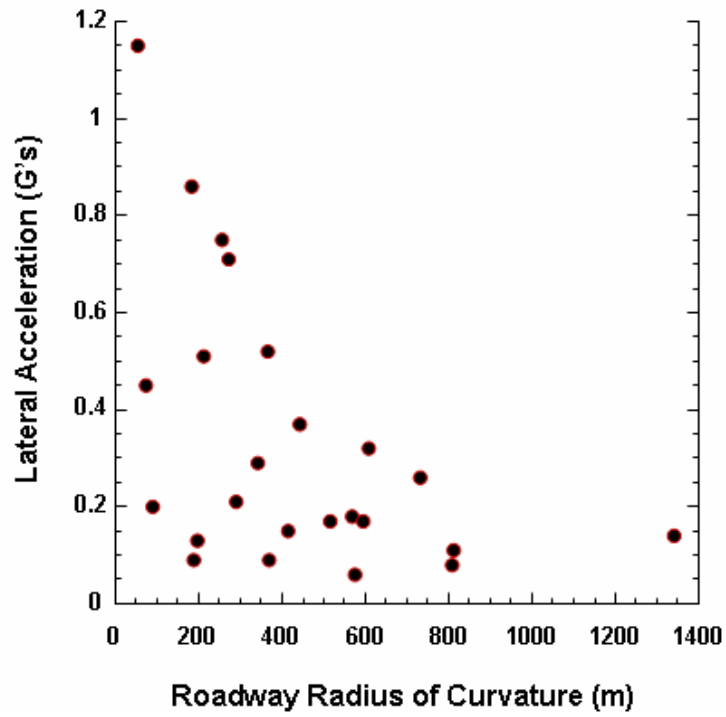


Figure 8. Lateral Acceleration vs Roadway Radius of Curvature

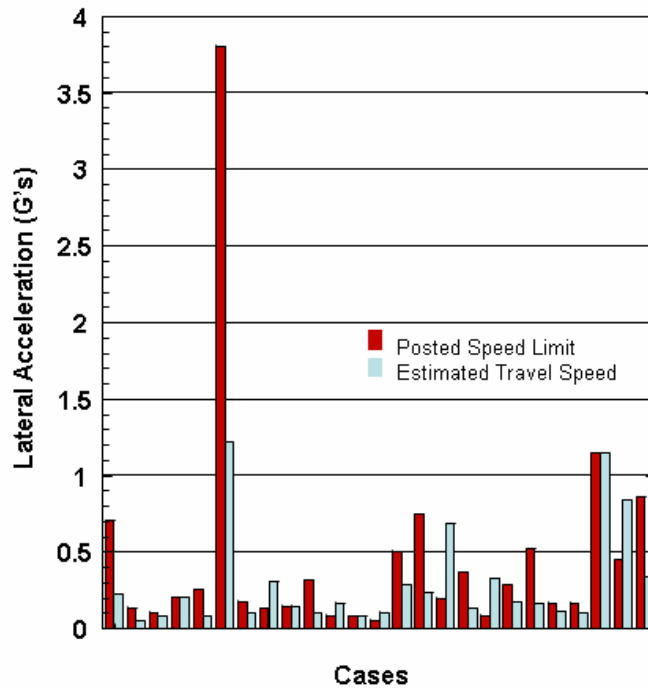
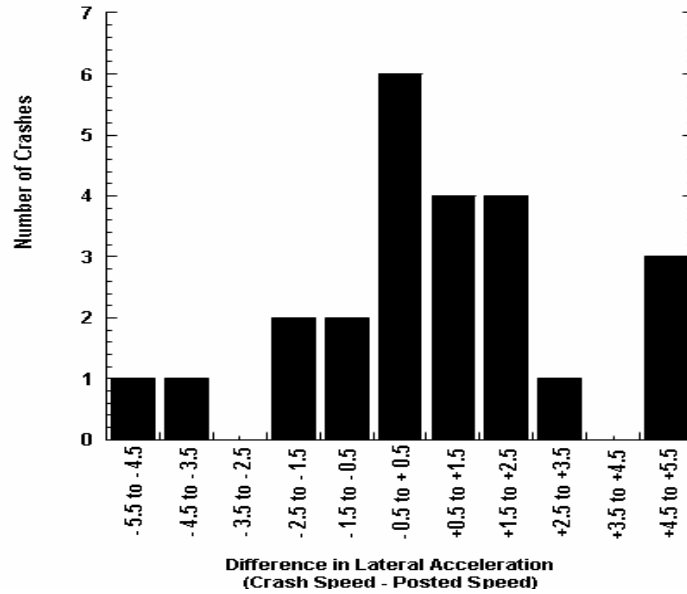


Figure 9. Case by Case Comparison of Posted Speed and Crash Speed Lateral Accelerations



**Figure 10. Bar Chart Showing Number of Crashes vs Difference in Lateral Acceleration (Crash Speed Minus Posted Speed in m/sec<sup>2</sup>)**

## Discussion

The use of orthoimagery to supplement the FARS database for motorcycle crashes has allowed us to determine the road curvature at the crash scene for 25 single vehicle crashes involving collision with a guardrail on a curved road. Lateral acceleration values based upon the posted speed limit and the estimated travel speed of the motorcycle prior to the collision event were calculated using the orthoimagery derived road curvatures.

Rider, vehicle and roadway characteristics, singly or in combination, are potential factors that can influence the maximum lateral acceleration values sustainable on these curves. Rider factors such as age, experience, training and drug use can clearly influence the driver's perception of risk and his understanding of the motorcycle's handling capabilities. Roadway factors include pavement type, surface condition, grade and elevation. Motorcycle type, weight, power and tire properties can also affect the lateral acceleration achievable by the rider without loss of control.

There is a dearth of data available on the lateral acceleration levels that average motorcycle riders are willing (or able) to achieve when negotiating a curve. For passenger vehicles, past research has indicated that the maximum lateral acceleration values drivers are willing to subject themselves to in crash type

situations falls in the range of 0.3 to 0.5 g's even though the cornering capabilities of vehicles vastly exceed these levels [13].

Thus, it may be reasonable to assume that the average motorcycle rider would typically negotiate a curve at a lateral acceleration level less than 0.5 g's. If one uses this assumption, then some interesting observations can be gleaned from the data in Table 2 and Figures 9 and 10. In seven of the selected cases (highlighted in blue in Table 2), the estimated travel speed resulted in a lateral acceleration level in excess of 0.5g's. Five of these were in excess of 0.7g's. It is assumed that a primary causal factor for these fatalities may have been a direct result of the rider entering the curve at too high a rate of speed to successfully negotiate the curve.

It is also noted that for the vast majority of curved roadways examined, the lateral acceleration one would experience when traveling at the posted speed limit was well below 0.4g's. However, in four cases (highlighted in green in Table 2), the lateral acceleration derived for motorcycles traveling the *posted* speed limit was also in excess of 0.5g's. The lateral acceleration values for these cases ranged from 0.69 to 1.22g's. Of particular note is the fact that in three of these four cases, the estimated travel speed of the motorcyclist was *at or below* the posted speed limit. This would lend some credence to the



belief that 0.5g's may be too high a threshold for average motorcyclists to handle in curves.

For our study, only commonly available mid to high resolution orthoimagery was utilized in the analysis of crash locations, specifically those available through Google Earth. Google Earth is a dynamic service which continually updates the orthoimagery they provide. During our investigation, roughly 50% of all motorcycle crashes on curved roadways with the first harmful event being a collision with a guardrail, were covered by mid to high resolution imagery. Due to expanded orthoimagery collection services, national organization and technological advances in collection methods, it is reasonable to assume that high resolution coverage of areas should increase in the future.

## CONCLUSIONS & RECOMMENDATIONS

This study illustrates the opportunity to increase our understanding of fatal motorcycle crashes by using geocoded crash data and orthoimages. Together these tools enable analysts to identify crash locations and visualize and measure crash scene roadway characteristics. Simple calculations of posted and crash lateral accelerations permit the identification of roadways with potential problems. For example, four curved roadways were identified in the analyses where the lateral accelerations calculated for the posted speed limits exceed the commonly accepted threshold of 0.5g's.

Further analyses could be strengthened if the accuracy of crash locations was improved. Currently, crash locations are approximate and include both recorded error and geocoded error. For example, the current accuracy is not sufficient to determine which side of the road the crash occurred on. Including direction of travel in FARS is recommended to overcome this hurdle.

## ACKNOWLEDGEMENTS

The authors would like to acknowledge and thank Mr. Barry Eisemann (NHTSA/NCSA) for making the geocoded FARS data available, and Mr. Louis V. Lombardo (NHTSA) for his technical guidance. This work was supported by Grant No. DTFH61-98-X-00103 from the Federal Highway Administration (FHWA) to CUBRC's Center for Transportation Injury Research.

## REFERENCES

- [1] Shankar U (NHTSA NCSA), "Fatal Single Vehicle Motorcycle Crashes", Technical Report DOT HS 809 360, Oct 2001.
- [2] Coben J., Steiner C, Owens P, 'Motorcycle-related hospitalizations in the United States, 2001'. American Journal of Preventive Medicine, Volume 27, Issue 5, Pages 355-362, 2004
- [3] McGwin G, Whatley J, Metzger J, Valent F, Barbone F, Rue LW III, 'The Effect of State Motorcycle Licensing Laws on Motorcycle Driver Mortality Rates', The Journal of Trauma, Injury, Infection, and Critical Care, Volume 56, Number 2, February 2004
- [4] Pierce JA, Ray LU, Wood S, Murrin P, 'Creating and Using a Geographic Information System for Motor Vehicle-Related Injury Surveillance in San Diego County.' Topics in Emergency Medicine. Emergency Medical Services. 21(1):26-31, March 1999.
- [5] Flanigan M, Blatt A, Lombardo L, Mancuso M, Miller M, Wiles D, Pirson H, Hwang J, Thill JC, Majka K, 'Assessment of Air Medical Coverage Using the Atlas & Database of Air Medical Services (ADAMS); Correlations with Reduced Highway Fatality Rates', Air Medical Journal, July / August 2005, p. 151
- [6] Black, W. 1991. Highway accidents: A spatial and temporal analysis. Transportation Research Record 1318, 75-82.
- [7] Thomas I, 'Spatial Data Aggregation: Exploratory Analysis of Road Accidents.' Accident Analysis and Prevention, 28:2, 251-264, 1996
- [8] Preusser DF, Williams AF, Ulmer RG, 'Analysis of Fatal Motorcycle Crashes: Crash Typing', Accident Analysis and Prevention, Vol. 27, No. 6, pp. 845-851, 1995
- [9] Strathman JG, Duecker KJ, Zhang J, Williams T, 'Analysis of Design Attributes and Crashes on the Oregon Highway System', Oregon Department of Transportation, Report FHWA-OR-RD-02-01, August 2001
- [10] "Content Standards for Digital Orthoimagery", Subcommittee on Base Cartographic Data, Federal Geographic Data Committee, FGDC-STD-008-1999, Feb 1999.
- [11] Fatality Analysis Reporting System (FARS), <http://www-fars.nhtsa.dot.gov>
- [12] 2006 Motorcycle Safety Program Plan, NHTSA, DOT HS 810 615, June 2006.
- [13] "An Assessment of the National Highway Traffic Safety Administration's Rating System for Rollover Resistance: Special Report 265" (2002), p. 34

# INTELLIGENT TRANSPORT SYSTEMS AND MOTORCYCLE SAFETY

**Megan Bayly**  
**Simon Hosking**  
**Michael Regan**

Monash University Accident Research Centre  
Australia  
Paper number 07-0301

## ABSTRACT

In comparison to the widespread advancement of safety-enhancing technologies for passenger vehicles, there has been only limited development of Intelligent Transport Systems (ITS) for motorcycles. Considering the international over-representation of motorcyclists in crash statistics, in particular, the high incidence of loss of control crashes and multiple-vehicle crashes and the critical issue of motorcycle conspicuity, it would appear that the development of ITS for motorcycles should be given greater priority. The current review aimed to investigate the extent to which ITS have been applied to motorcycles (including both existing and emerging technologies) and discuss these ITS according to their likely safety benefits to motorcycle safety. A literature review and expert consultations confirmed that very few motorcycle-specific ITS currently exist, with advanced braking systems a notable exception, although a number of prototype systems have been developed. The potential to adapt emerging and existing ITS for other vehicles to motorcycles is also highlighted. Technologies that were seen to enhance the stability and braking power of motorcycles have been regarded with highest priority as these are most likely to be relevant to almost all motorcycle crash types, particularly loss of control crashes. Future motorcycle ITS developments must be safety-driven, but also consider issues such as acceptability. Evaluative studies of existing and emerging systems are a critical next step.

## INTRODUCTION

This review was conducted in recognition of the lack of Intelligent Transport System (ITS) developments for motorcycles. There are numerous safety enhancing technologies for passenger and commercial vehicles, however, motorcycles to this point have been largely overlooked by both ITS and vehicle manufacturers. This is despite estimates that system-wide deployment of ITS would reduce crashes by up to 50% (e.g.,<sup>1,2,3</sup>). The demonstrated safety advantages of ITS for passenger and

commercial vehicles (e.g.,<sup>4,5,6,7,8</sup>) suggests that ITS for motorcycles could also have important implications for reducing motorcycle crashes. The aim of this review was to provide a snapshot of the technological research and development currently being undertaken with regard to ITS and motorcycle safety. In addition, advancements in ITS for other vehicle domains have been considered for their potential to be adapted to motorcycles. This paper provides an overview of a range of in-vehicle ITS that may be implemented in the motorcycling domain, and that address those crashes that are typical for motorcycle riders.

ITS has been classified both in terms of the location of the system, and the time at which it takes effect. System location classifications of ITS are: (i) in-vehicle-based, (ii) infrastructure-based, and (iii) cooperative systems that integrate in-vehicle and infrastructure-based technologies and allow vehicle-vehicle or vehicle-environment interactions. An alternative and complementary ITS classification differentiates the time at which the system takes effect. Active systems are crash avoidance technologies that serve to prevent a crash from occurring, either through constant support to the user, or intervention in an emergency situation. Passive systems are crash mitigation systems that serve to reduce the effects of the crash once it has occurred or is occurring. Combined active and passive systems (CAPS) combine both these functions. While numerous types of ITS exist that may enhance different aspects of the road user's experience (e.g., in-vehicle information systems), only ITS which are designed to enhance the safety of vehicle occupants are reviewed in this paper. Furthermore, since infrastructure-based ITS have potential benefits for all road users and there are no infrastructure-based ITS developed specifically for motorcyclists, only emerging and existing in-vehicle and cooperative ITS will be reviewed.

In order to appreciate which ITS would be most beneficial for motorcycles, an understanding of the critical safety issues relevant to motorcycling is

needed, as motorcycle crashes tend to show different characteristics to other vehicle types. The over-representation of motorcyclists in crash statistics is an international problem that is reflected in Australian crash statistics. Australian motorcyclists are three times more likely to be involved in a casualty crash than car drivers<sup>9</sup> and comprised 14% of the national road toll in 2005<sup>10</sup>. The overrepresentation of these crashes is evident in that only 3% of registered vehicles in the Australian vehicle fleet were motorcycles<sup>9</sup>.

Multiple-vehicle crashes (head-on, side-swipe, failing to give-way) and loss of control crashes on both straight and curved sections of road are dominant types of fatal and serious injury motorcycle crashes. It has been found that up to 75% of all motorcycle crashes involve other vehicles<sup>11</sup>. The MAIDS study<sup>12</sup> reported 60% of all motorcycle crashes involved passenger cars, and that 41.3% of US motorcycle crashes are run off-road, while approximately 10% involved head-on crashes with other vehicles<sup>13</sup>. It has also been repeatedly shown that rider error is a significant crash factor<sup>11 12 13</sup>, that alcohol is a factor in 25-53% of crashes, and that unlicensed riders are involved in significantly more crashes than licensed riders<sup>11 12</sup>. A common attribute of multiple vehicle crash causation is conspicuity, where the driver of the other vehicle claims not to have seen the motorcycle<sup>11 12</sup>. This may be due to driver inattention, temporary obstruction of the view of the motorcyclist, or low conspicuity of the motorcycle. Other factors, such as poor weather, poor visibility and poor road surface conditions have rarely found to be causal factors in motorcycle crashes, and collisions with pedestrians and animals comprise relatively small proportions of crashes<sup>11 12</sup>.

While these key safety issues may show patterns unique to motorcycling, there is potential for ITS developed for other vehicles to also address these issues. ITS currently exist that may address motorcycle crashes both in terms of crash prevention and harm minimisation. The extent to which this has already occurred will be reviewed in the following sections.

## **THE STATE OF DEVELOPMENT OF ITS SYSTEMS FOR MOTORCYCLES**

The lack of ITS-specific applications for motorcycles has not gone unnoticed in both the fields of motorcycling safety and ITS research and development. While vulnerable road users are often considered in the ITS literature (e.g.,<sup>14</sup>), widespread applications of ITS to motorcycling safety have not

yet occurred despite the clear need and potential for such safety countermeasures<sup>15 16 17</sup>. Motorcycling safety bodies have also called for ITS developments and criticised the lack of consideration given to motorcycles in the ITS field<sup>18</sup>. The potential for inter-vehicle communication systems to address motorcycle conspicuity issues has been previously recognised<sup>12</sup>, and stimulation of development of conspicuity enhancing technologies such as daytime running lights (DRLs), and advanced braking systems such as anti-lock braking systems (ABS) and linked braking systems, have been encouraged<sup>19</sup>.

One of the first discussions of the potential for ITS adaptation to motorcycles postulated that while ITS have been developed for passenger vehicles, this does not preclude their modification for other vehicle types<sup>15</sup>. ABS, blind spot warning systems, advanced lighting systems, intersection collision monitoring, and driver (rider) monitoring, among others, were identified as existing ITS for other vehicles that could practically and usefully be adapted to motorcycles<sup>15</sup>. Furthermore, systems such as adaptive cruise control, traction warnings, weather warnings, vision enhancement, rider monitoring, and curve speed warnings could also be applied to the motorcycling domain<sup>20</sup>. The notion of ITS for collision avoidance and stability enhancement in motorcycles has also previously been highlighted<sup>17</sup>.

The forerunners of most ITS developments of motorcycles stem from Japan's Advanced Safety Vehicle (ASV) initiative. The ASV program is concerned with the development of technologies for crash avoidance and crash minimisation. Several motorcycle manufacturers participating in this research program have developed a number of prototype in-vehicle systems. Areas of focus for these projects have included driver inattention, rear-end collisions and passive safety<sup>21</sup>.

In summary, there is potential for ITS for motorcycles to address issues such as conspicuity and vehicle handling, and multiple vehicle collisions. As already noted, the vast majority of ITS developments to date have focused on car safety and, to a lesser extent, heavy vehicle safety. Very few motorcycle-specific ITS have been developed, although active research programs are beginning to address this. However, as seen with recent trials of ISA on motorcycles conducted in Sweden (by SWECO and IMITA) and in the United Kingdom by MIRA<sup>22</sup>, there is potential for existing in-vehicle ITS to be adapted to motorcycles.

## EXISTING AND EMERGING ITS FOR MOTORCYCLES

In this section the various ITS that may be applied to the motorcycling domain will be reviewed. The following section provides a brief description of existing and emerging ITS for all vehicle types that show potential to address the safety issues already highlighted. Each ITS has been categorised nominally according to function. A functional overview of each system is provided, with a description of the state of development of these systems, for example, whether it is commercially available, or in prototype stage. Foreseen or known issues associated these systems are also identified. It should be noted that the information provided in this review is based on an extensive search of the literature and consultation with international industry experts in motorcycling and ITS, which formed the basis of an earlier report<sup>23</sup>. However, it is quite possible that some emerging ITS for motorcycles have not been reviewed here if such information has not been made publicly available.

### Active Safety ITS

#### Crash Avoidance ITS

Crash avoidance ITS are active systems that alert the rider to potential hazards in the road environment and/or dangerous riding behaviours. *Collision warning systems* are designed to detect potential hazards on the road using radar, laser, or infrared to monitor the frontal, rear and/or lateral roadway. Feedback is provided to the user when a hazard is detected. Some systems may also activate an automated collision avoidance function. The latter typically involve system intervention of steering and/or braking functions, and therefore adaptation of this function to motorcycles could be problematic. *Following distance warning systems* combine the information from forward-facing infrared cameras or radars with acceleration sensors to determine the time or distance headway to the leading vehicle, and alert the driver if some minimum headway threshold is reached. *Inter-vehicle communication* is a cooperative ITS that utilises GPS technology to communicate between vehicles. Information regarding location, direction and vehicle speed is transmitted between vehicles, allowing advanced warning of other approaching vehicles. Infrastructure-based versions of inter-vehicle communications systems, termed *intersection collision avoidance*, are also emerging.

*Lane departure warning systems* monitor the lateral position of the vehicle in relation to the lane edges with radar, infrared cameras, or similar detection hardware. If the vehicle is about to depart the lane, the departure warning system provides visual, auditory or tactile feedback to the user. *Lane keeping systems* utilise similar functions, and additionally apply steering force that prevents the vehicle from drifting further, which again may not be suitable for motorcycles. *Pre-crash systems* combine the active and passive collision avoidance technologies described above (CAPS systems). For example, potential collisions activate the pre-crash system that in turn primes other vehicle systems, such as advanced braking systems or passive ITS in order to minimise the effects of the crash.

Crash avoidance ITS have not been widely developed for motorcycles. However, some of these systems have clear potential for improving motorcycle safety and can be implemented without affecting the rider's control over the motorcycle. While collision warning systems are not commercially available for motorcycles, Yamaha's ASV-2 prototype vehicle includes such a system. Similar technologies that detect animals and pedestrians are currently being developed for passenger vehicles that may also apply to the motorcycling domain. The benefits of these latter systems for motorcycle use may be limited given that pedestrian and animal crashes comprise relatively small proportions of motorcycle crashes<sup>11</sup><sup>12</sup>. Inter-vehicle communication systems may prove very important for preventing the larger proportion of motorcycle-related multiple vehicle crashes occurring in urban areas<sup>12</sup>, in particular crashes occurring at intersections where the visual conspicuity of motorcycle riders and driver's inattention to approaching motorcycles are often factors<sup>24</sup>. It should be noted, however, that these systems require a large proportion of the vehicle fleet to have adapted this technology in order for it to have notable impact on crashes.

Following distance warning systems, lane keeping/departure warning systems, and pre-crash systems that link ABS with forward collision sensors, while commercially available on four-wheeled vehicles, have not yet been developed for motorcycles. Implementation of systems that include automation or intervention of vehicle functions would be problematic unless reliable steering and braking control systems were developed, and even then there may be low acceptability by motorcycle riders, who have been shown to ride motorcycles for reasons other than just transportation<sup>25</sup>. Furthermore, the potential positive effects of lane keeping and lane

departure warning systems on reducing run-off-road crashes may attenuate if such systems do not take into account purposeful changes in lane position such as when the motorcycle splits lanes.

### **Stability and Braking Enhancing ITS**

Numerous ITS exist that serve to increase the braking potential of vehicles. One common such system is *anti-lock brakes*, which controls and optimises the braking performance of the vehicle and prevents wheels from locking under forceful braking events. ABS monitors the rotation of the wheels, and regulates braking pressure should they begin to lock. Contact between the wheels and the road is maximised, and the stability and path of the vehicle is maintained. Another system which similarly maximises the braking potential of the vehicle in emergency situations is *brake assist*. Brake assist serves to reduce the stopping distances of the vehicle. Forceful braking pressure is detected, and the system applies additional hydraulic pressure to the brakes. Brake assist has been developed in recognition that maximum braking pressure is rarely achieved in emergency situations. This may be especially true of motorcycles, where the independent nature of the front and rear brakes means they are not always optimally applied. *Linked braking systems* aim to counteract the potential of non-optimum motorcycle braking behaviour by applying dual braking pressure (i.e. from both brakes) even when only one brake is applied.

Other systems address the stability characteristics of the vehicle. *Roll stability systems* monitor the yaw rate and speed of the vehicle, and the rider is warned if a critical threshold of tilt has been breached. Up to one-third of crashes have been found to occur on curves<sup>12</sup>, and roll stability systems for motorcycles may at least partially address this. *Electronic stability control* (ESC) detects wheel traction, lateral acceleration, yaw rate, steering wheel position and speed and determines whether the actual course of the vehicle is the same as the driver's intended course. If there is a discrepancy, ESC applies individual braking pressure to the wheels to correct the vehicles trajectory.

Although ESC is commercially available for passenger vehicles under numerous product names, stability enhancing ITS are less advanced in terms of development for motorcycles. In fact, whether such a system would be feasibly adapted to a two-wheeled vehicle is questionable due to the unique stability and braking characteristics of two wheel vehicles. However, given that this review has

attempted to encompass all ITS that may potentially address motorcycles safety issues, of which stability (in loss of control crashes) is a key factor, ESC can justifiably be included here. Furthermore, ESC in other vehicles has been associated with single-vehicle crash reductions of up to 67% (e.g.,<sup>26 27 28</sup>). Roll-stability systems for motorcycles are more advanced. While this technology has largely been developed for commercial vehicles and SUV's, tilt sensors are commercially available for motorcycles.

Advanced braking systems are a leading area of ITS developments for motorcycles, and much of the braking technology reviewed here already exists for motorcycles. Loss-of-control crashes may be significantly reduced with ABS for motorcycles. Until recently, however, surprisingly little implementation of ABS in motorcycles had occurred<sup>29</sup> despite ABS for cars and light trucks being available for many years, and numerous discussions in the literature of the potential benefits of ABS for motorcycles (e.g.,<sup>12 15</sup>). A notable exception is developments in ABS and other advanced braking systems from Honda. The only application as yet of brake assist to motorcycles has been to Yamaha's ASV-2 Model 1. Linked braking systems are a better-established ITS. These systems may be combined with brake assist or ABS (as in Honda's advanced braking systems). Evaluative studies of implemented advanced braking systems for motorcycles are not publicly available.

### **Visibility-enhancing Systems**

Advanced lighting systems should serve two benefits to motorcyclists. First, they may address the unique safety issue of conspicuity of motorcycles to other road users. Second, they may provide better illumination of the road environment for motorcycle riders. Serving the former function, *daytime running lights* provide a constant frontal light whenever the vehicle is in operation, typically employing an existing headlight at around 80% of its normal luminance. Traditional fixed headlights tend to illuminate the shoulder of the road when cornering rather than the intended path of the vehicle. Motorcycle DRLs have been associated with considerable reductions in daytime crashes in several Asian countries (e.g.,<sup>30 31 32</sup>). *Adaptive front lighting*, or *active headlights*, use input from vehicle speed and angular velocity sensors to adjust the angle of the headlight when cornering. A rotating mechanism in the headlight maintains a parallel angle with the road at all times, maximising illumination of the road at night<sup>33</sup>. There is potential for this system to both enhance the conspicuity of the motorcycle to other

vehicles while cornering, as well as the primary aim of improving the visibility of the riding environment. Therefore, adaptive front lighting may address the significant safety issues of conspicuity and crashes occurring on curves, at least at night-time. *Vision enhancement systems* provide an augmented view of the road environment. These may employ radar, laser or infrared imaging to detect objects on the road, and overlay this enhanced image on the windshield of the vehicle, and potentially the visor of the rider (see helmet mounted displays in the next section). These systems enhance the riders' functional viewing distance and increase the contrast of objects in poor visibility conditions such as at night-time or in fog.

DRLs are a technically mature ITS, are a standard feature on many motorcycles, and have been made mandatory in a number of jurisdictions. DRLs are widely considered an effective and economical vehicle safety technology<sup>34</sup>. There is debate whether daytime DRLs should be classified as ITS. However, given that DRLs are conspicuity-enhancing in-vehicle technologies with well-demonstrated safety enhancing effects, they have been included in this review. Adaptive front lighting is a less technically mature ITS, although such a system was implemented on Yamaha's ASV-2 Model 1. Vision enhancement systems are an emerging technology for all vehicle types.

### **Advanced Driver Assistance Systems**

Advanced driver assistance systems (ADAS) serve to provide additional information available to the user, and/or present integrated information from various warning ITS and the vehicle instrumentation panel. Additionally, numerous systems exist that address specific elements of the driving task. For example, *curve speed warnings* indicate to the rider that the current speed is inappropriate for upcoming changes in the road geometry. Such information is discerned cooperatively, through roadside beacons or GPS systems. *Road surface monitoring systems* continuously uses laser, radar, and/or video imaging to screen the road surface for abnormalities, such as debris, ice or potholes. The system may be used to either provide additional information to the rider, or integrate with advanced braking or collision avoidance systems to increase stopping distances and headways to suit the road conditions<sup>35</sup>. *Helmet-mounted* displays project vehicle information onto the rider onto an area of the helmet visor. These systems serve to eliminate the need for the rider to take their eyes off the road to view vehicle information, such as speed and RPM. The display is projected at a similar focal distance as the roadway,

so that the rider does not need to re-focus while viewing the information. However, the extent to which driver inattention or distraction resulting from looking at the vehicle's instrumentation panels is a crash factor is largely unknown at this stage. *Rear-view displays* provide the user a view of the roadway behind the vehicle. Rear-facing cameras continuously capture the road environment, and display this information either on visual interfaces within the vehicle, or on the upper area of the helmet visor. Such systems may help prevent multiple-vehicle crashes, such as rear-end or side-swipe crashes, although it is worth noting these have not been identified as leading motorcycle crash types. *Intelligent speed adaptation (ISA)* provides speed control to the user. Speed zones are transmitted cooperatively to the vehicle, and the system either passively alerts the user when excessive speeding occurs, or in intervening systems, prevents the driver from exceeding the speed limit. In passenger vehicles, this may be in the form of upward pressure on the accelerator pedal.

An ADAS 'rider support system' introduced on the Yamaha ASV-2 incorporates information from the forward collision warning system, curve speed warning system, speedometer, and navigation system, and conveys this information on a visual display on the console and via an earpiece worn by the rider. Integrated systems such as this are not specific to particular crash types, but serve to reduce rider workload and enhance the information available to the rider and are therefore expected to indirectly enhance motorcycle safety. Curve speed warnings are in an initial stage of development. Similar infrastructure-based systems for commercial vehicles currently exist, however, the only in-vehicle application of such technology to motorcycles known to date has been in Yamaha's ASV-2. Several types of commercially available visual display systems for motorcycles currently exist and are relatively advanced. Existing helmet-mounted display systems project information such as speed, fuel levels, RPM, and gear position to the rider's visor. Road surface monitoring technology is emerging in all vehicle types, and may serve to reduce loss of control crashes, although road surface conditions are rarely cited as key factors in motorcycle crashes<sup>11 12</sup>. While ISA for motorcycles has been tested in a number of European trials, no formal reports of these investigations are currently available. However, it was communicated to the authors that the different acceleration and deceleration patterns of motorcycles compared to other vehicles, as well as technical considerations such as throttle resistance as feedback and vibration from the motorcycle must be addressed.

Therefore, adaptation of ISA is at a formative stage. Notably, it has been shown that motorcycle accidents are not often characterised by excessive speed<sup>12</sup>.

### Driver Management/Monitoring Systems

Driver management/monitoring systems restrict or monitor the vehicle operator and may prevent an individual from turning on the vehicle's ignition, and/or continuously assess the ability of the operator to safely operate the vehicle. For example, *alcohol interlocks* analyse the breath alcohol content (BAC) of the user. The system typically disables the ignition of the vehicle, which is only enabled if the breath content of the vehicle is below a predetermined BAC level. The breath testing device may be mounted on the vehicle, or a device on the key fob. *Driver vigilance systems* monitor the status of the driver and/or driving performance and determine whether the driver is fatigued or inattentive. These systems monitor factors such as eye movement, steering wheel grip, lateral lane movement, or may involve devices that require regular input from the driver. While issues such as fatigue and intoxication are significant safety issues for car and heavy vehicle domains, where systems that monitor driving performance have been estimated to reduce fatal and injury-related crashes by 10-15%<sup>2</sup>, less is known about their potential impact on motorcycle crash rates.

*Electronic licenses* are mechanisms that prevent unauthorised individuals from operating a given vehicle. The engine is immobilised until an authorised card is present. The role of unlicensed vehicle operation in crash rates is largely unknown, although it has been shown that unlicensed riding is a factor in a significant proportion of crashes<sup>11</sup>. However, it is a common feature of motorcycle graduated licensing schemes to include power restrictions for learner riders, and this ITS may provide a mechanism for enforcement of these restrictions.

Alcohol interlocks on motorcycles for riders who have been convicted with riding over a legal BAC have been trialled in Australia, but as yet their effectiveness has not been evaluated. Driver vigilance monitoring systems are emerging technologies in other vehicle domains, but have not yet been applied to motorcycles and there are technical challenges in adapting such systems to inside the motorcycle helmet. Electronic licences are an emerging technology, with heavy vehicle fleet management leading the development of such systems. A similar technology, referred to as *smart cards*, has been

developed for motorcycles by Honda to reduce motorcycle theft, where the ignition can only be activated by one of these cards.

### Passive Safety ITS

Passive safety systems are those that take effect during or immediately after a crash in order to minimise harm to the vehicle occupant. For example *airbags* absorb the kinetic energy of the vehicle occupant during a crash, reducing injury severity. Airbags installed below the seat inflate when triggered by impact sensors in the front wheels, and are relevant to all frontal impact crashes. However, unique issues concern motorcycle airbags since they must be designed to take into account that the position of the rider is not always upright such that there may be smaller distances between the rider's face and the airbag than that typical for car drivers, and that the presence of pillion passengers will affect the forward force of the rider<sup>36</sup>. A motorcycle-specific innovation is inflatable *airbag jackets* that deploy when a cable connecting the jacket to the vehicle is severed when the rider is propelled from the vehicle, cushioning the rider from impact with the ground. *Automatic crash notification (ACN) systems* detect the occurrence of a crash through vehicle speed, tilt, and deceleration sensors, and automatically notify emergency services. GPS units inform emergency services of the vehicle's location. ACN should perform several important functions<sup>37</sup>, such as informing the user that emergency services have been contacted and when they are due to arrive through auditory and/or visual displays, providing information to the user from the emergency services operators, and updating this information in real-time. *Emergency lighting systems* illuminate the vehicle in the event of a crash (a passive system) and serves to enhance the visibility of the vehicle to other road users and emergency services. Emergency lighting systems for motorcycles are commercially available.

Relatively fewer passive than active ITS applications exist that are relevant to motorcycling. However, of those systems identified here, it is important to note that these systems are in considerably advanced development for motorcycles, particularly with regard to airbags. In-vehicle airbag systems have been developed by Honda through the Advanced Safety Vehicle program. These systems are currently commercially available, although no evaluative literature regarding their effectiveness could be identified. ACN systems for motorcycles are in a preliminary stage of development, and initial tests of their adaptability to motorcycles have been conducted<sup>38</sup>. No formal evaluations of their

effectiveness were available. Airbags, airbag jackets and automatic crash notification systems are applicable to all crash types that may result in serious injury or fatality. Systems that minimise occupant injury or improve the response times of emergency services have previously been predicted to improve crash outcomes. For example, it has been estimated that of crashes in which a motorcycle airbag could have been triggered, 44% would have resulted in less serious injury outcomes for the motorcyclists<sup>39</sup>. Numerous studies have predicted that automatic crash notification systems may be effective (for at least passenger vehicles) in reducing serious injury and fatal crashes by between 5-15%<sup>40 41 42</sup>. At least one Australian emergency lighting exists that product incorporates with a roll stability warning device currently.

## CONCLUSION

The present review, has identified nine existing safety enhancing ITS systems for motorcycles. In addition, eight emerging technologies currently in prototype form, and several additional 'potential' systems have been described. These have been discussed in terms of the critical motorcycling safety issues, namely loss of control crashes, multiple vehicle crashes, and additional factors such as conspicuity, alcohol and unlicensed riding. While some of these systems serve to address specific safety issues, such as interlocks and alcohol-related crashes, other systems will show comprehensive benefits across a number of crash types. For example, advanced braking systems are relevant to any event where forceful braking is applied. Importantly, this is one area of ITS development that has shown a significant amount of development. However to date there are no available studies on the effectiveness of the existing systems identified, with the exception of DRLs. In addition to technical development, future research should address issues such as acceptability, usability, negative behavioural adaptation, and further in-depth analysis of crash causal factors such as distraction.

## ACKNOWLEDGEMENTS

The authors would like to thank VicRoads, and in particular Chris Brennan, for assistance in funding and reviewing this research. The authors also wish to thank Brent Stafford, of ITS Australia, and Professor Narelle Haworth, from the Centre for Accident Research & Road Safety - Queensland, for their input to the research.

## REFERENCES

- [1] McKeever, B.B. 1998. "Working paper: Estimating the potential safety benefits of intelligent transport systems." Washington DC: Mitretek Systems.
- [2] Rumar, K. Fleury, D. Kildebogaard, J. Lind, G. Mauro, V. Berry, J. Carsten, O. Heijer, T. Kulmala, R. Machata, K. and Zackor, I. 1999. "Intelligent Transportation Systems and Road Safety." Report prepared for the European Transport Council, Brussels.
- [3] OECD. 2003. "Road safety: Impact of new technologies." Paris, France: Organisation for Economic Cooperation and Development.
- [4] Lee, J.D. McGehee, D.V. Brown, T.L. and Reyes, M.L. 2002. "Collision warning timing, driver distraction, and driver response to imminent rear-end collisions in a high-fidelity driving simulator". *Human Factors*, 44, 314-335.
- [5] Farmer, C.M. Wells, J.K. and Lund, A.K. 2003. "Effects of head restraint and seat redesign on neck injury risk in rear-end crashes." *Traffic Injury Prevention*, 4, 83-90.
- [6] Kulmala, R. 1997. "The potential of ITS to improve safety on rural roads." *Proceedings of the 4th World Congress on Intelligent Transport Systems* (Berlin, Germany Oct. 21-24).
- [7] Maccubbin, R.P. Staples, B.L. Mercer, M.R. Kabir, F. Abedon, D.R. and Bunch, J.A. 2005. "Intelligent Transport Systems benefits, costs, and lessons learned: 2005 update." FHWA-OP-05-002. Washington DC: Mitretek Systems.
- [8] NHTSA. 1996. "Effectiveness of occupant protection systems and their use." Washington DC: National Highway Traffic Safety Administration.
- [9] Australian Bureau of Statistics. 1996. "Australian Social Trends." Available at: [www.abs.gov.au/ausstats/](http://www.abs.gov.au/ausstats/), accessed 24/05/06.
- [10] Traffic Accident Commission. 2006. "Motorcycle Crash Data." Available at: [www.tacsafety.com.au](http://www.tacsafety.com.au), accessed 23/05/06
- [11] Hurt, H.H. Oullet, J.V. and Thom, D.R. 1981. "Motorcycle Accident Cause Factors and Identification of Countermeasures. Volume 1: Technical Report." Traffic Safety Centre, University



of Southern California.

[12] Association des Constructeurs Européens de Motorcycle. 2004. "The motorcycle industry in Europe: A plan for action." Available at: <http://www.acembike.org/html/start.htm>, accessed 05/02/2007.

[13] Preusser, D.F. Williams, A.F. and Ulmer, R.G. 1995. Analysis of fatal motorcycle crashes: Crash typing. *Accident Analysis and Prevention*, 27, 845-851.

[14] Lawrence, G.J.L. Hardy, B.J. Carroll, J.A. Donaldson, W.M.S. Visviskis C. and Peel, D.A. 2004. "A study on the feasibility of measures relating to the protection of pedestrians and other vulnerable road users." *Transportation Research Library*.

[15] Hsu, T.P. 1997. "Proposed ITS issues on motorcycle traffic." *Proceedings of the 4th World Congress on Intelligent Transport Systems*, (Berlin, Germany, June 6-7).

[16] Regan, M.A. Oxley, J.A. Godley, S.T. and Tingvall, C. 2001. "Intelligent Transport Systems: Safety and Human Factors Issues." Royal Automobile Club of Victoria Research Report 01/01. RACV: Melbourne, Australia.

[17] Thirumalai, K. 2001. "ITS innovation challenges for 21st century transportation safety and services market." 8th ITS World Congress (Sydney, Australia, Sept. 30- Oct. 4).

[18] Motorcycle Safety Foundation. 2000. "National Agenda for Motorcycle Safety." U.S. Department of Transportation. Available at: [www.nhtsa.dot.gov](http://www.nhtsa.dot.gov), accessed 3/07/06.

[19] Federation of European Motorcyclists Associations. 2004. "European Agenda for Motorcycle Safety. Outline." Available at: [http://www.fema.ridersrights.org/safety/EAMS\\_febr04.pdf](http://www.fema.ridersrights.org/safety/EAMS_febr04.pdf), accessed 05/02/07.

[20] Bishop, R. 2002. "The road ahead for intelligent vehicle systems: What's in store for riders?" Presented at the 8th Annual Minnesota Motorcycle Safety Conference (March).

[21] Asanuma, N. Kawai, M. Takahashi, A. Shigenari, R. and Ochi, K. 2000. "Intelligent technologies of ASV: The research and development of ASV-2 in Honda." *Proceedings of the 7th Annual Intelligent Transport Systems World Congress*

(Turin, Italy, Nov. 6-9).

[22] Fowkes, M. 2004. "News on ISA PTW." Presented at the International Working Group on Speed Control (Barcelona, Spain).

[23] Bayly, M. Regan, M. Hosking, S. 2006. *Intelligent Transport Systems and Motorcycle Safety*. Monash University Accident Research Centre Report 260. MUARC: Clayton, Australia.

[24] Satomura, M. 2000. "Motorcycle detection system." *Smart Cruise 21-Demo* (Tsukuba, Japan, Nov. 28 - Dec. 1).

[25] Tham, K.Y. Seow, E. and Lau, G. 2004. "Pattern of injuries in helmeted motorcyclists in Singapore." *Emergency Medical Journal*, 21, 478-482.

[26] Bahouth, G. 2005. "Real world crash evaluation of vehicle stability control (VSC) technology." *Proceedings of the 19th International Technical Conference on the Enhanced Safety of Vehicles* (Washington DC, June 6-9).

[27] Dang, J. 2004. "Preliminary results analyzing the effectiveness of Electronic Stability Control (ESC) systems." DOT HS 809 790. Washington DC: U.S. Department of Transportation, National Highway Traffic Safety Administration.

[28] Farmer, C. 2004. "Effect of Electronic Stability Control on automobile crash risk." *Traffic Injury Prevention*, 5, 317-325.

[29] Ulleberg, P. 2003. "Motorcycle safety – A literature review and meta-analysis." *Institute of Transport Economics*, Norway.

[30] Umar, R.S.R. Mackay, M.G. and Hills, B.L. 1996. "Modelling of conspicuity-related motorcycle accidents in Seremban and Shah Alam, Malaysia." *Accident Analysis and Prevention*, 28, 325-332.

[31] Elfvik R. and Olsen S. 2003. "Daytime running lights. A systematic review of effects on road safety." TØI report 688/2003. Oslo. Available at: [http://www.toi.no/attach/a456292r623287/688\\_2003\\_sum.pdf](http://www.toi.no/attach/a456292r623287/688_2003_sum.pdf), accessed 05/06/07.

[32] Yuan, W. 2000. "The effectiveness of the 'ride-bright' legislation for motorcycles in Singapore." *Accident Analysis and Prevention*, 32, 559-563.

[33] Nakai, N. 2000. "Adaptive front lighting system

(for motorcycle).” Smart Cruise 21-Demo (Tsukuba, Japan, Nov. 28 - Dec. 1).

[34] Olssen, T. Truedsson, N. Xafis, V. Tomasevic, N. Logan, D. Fildes, B. and Kullgren, A. 2006. “Safecar II: A review and evaluation of vehicle safety features and systems.” Clayton, Australia: Monash University Accident Research Centre.

[35] Bishop, R. 2005. “Intelligent Vehicle Technology and Trends.” Norwood: Artech House.

[36] Takeshi, Y. 2000. “Airbag system for motorcycle.” Smart Cruise 21-Demo, (Tsukuba, Japan, Nov. 28 - Dec. 1).

[37] Campbell, J. Carney, C. and Kantowitz, B. 1998. “Human factors design guidelines for advanced traveler information systems (ATIS) and commercial vehicle operations.” FHWA-RD-98-057. Washington, Federal Highway Administration.

[38] Finlay, A. and Morphet, A. 2003. “ITS enabled motorcycle safety and security.” Proceedings of the 10th World Congress and Exhibition on Intelligent Transport Systems and Services (Madrid, Spain, Nov. 16-19).

[39] Berg, F.A. and Rücker, P. 2003. “Analysis of the benefit potential of a motorcycle airbag to improve rider safety – results from accident research and crash tests.” In 9th EAEC International Congress: European Automotive Industry Driving Global Changes (Paris, France, June 16-18).

[40] Abele, J. Kerlen, C. Krueger, S. Baum, H. Geißler, T. Grawenhoff, S. Schneider, J. and Schulz, W.H. 2005. “Exploratory study on the potential socio-economic impact of the introduction of intelligent safety systems in road vehicles.” Tetlow, Germany: VDI/VDE Innovation.

[41] eSafety Forum. 2005. “Final report and recommendations of the implementation road map working group.” (Brussels, Belgium, Oct. 18) [http://www.esafetysupport.org/en/esafety\\_activities/esafety\\_working\\_groups/implementation\\_road\\_map.htm](http://www.esafetysupport.org/en/esafety_activities/esafety_working_groups/implementation_road_map.htm)

[42] Apogee/Haggler Baillie. 1998. “The effects of urban form on travel and emission: Synthesis of the literature.” Washington DC: US Environmental Protection Urban and Economics Division.

# THE MOTORCYCLE INTEGRAL BRAKE SYSTEM MIB – AN ADVANCED BRAKE SOLUTION FOR HIGH PERFORMANCE MOTORCYCLES

**Oliver Hoffmann**

**Alfred Eckert**

**James Remfrey**

**Jürgen Woywod**

Continental Automotive Systems

Germany

Paper Number 07-0312

## ABSTRACT

Brake systems for motorcycles are available in many different designs with different technical solutions. Beginning with a conventional brake system with two independent circuits, an ABS system can be added to improve safety and stability. A combined brake system can be created to enhance safety and comfort by establishing a hydraulic connection between the front brake control and the rear caliper or vice versa.

The Motorcycle Integral Brake System MIB, which was introduced to the market in 2006, provides motorcycle manufacturers with the possibility to realize any combined integral functionality characteristic. In addition, the pressure in each brake circuit can be built up actively independently of any rider input, so that the system reacts appropriately in any riding situation. Integral brake functions can be adapted to the philosophy of the motorcycle manufacturer, and many additional functions which were impossible until now can be incorporated.

This paper describes the Motorcycle Integral Brake system, its operating principles compared with other brake systems, and its various hydraulic and functional possibilities.

## INTRODUCTION

Motorcycle brake systems are in a constant state of technical development. The driving force behind this development is the end consumer's desire for continuous improvements in comfort, riding pleasure and safety.

Increasing comfort means, on the one hand, development of brake systems in which slight corrections in speed can be achieved by applying minor forces to the hand brake lever. Here, the hand lever feeling should correspond with the feeling of deceleration and should reflect the deceleration performance.

Moreover, comfort is also increased by additional functions that can be realized with the brake system or in connection with other motorcycle systems. These include, for example, brake systems that effectively prevent rolling-back when starting on

inclines, or allow comfortable starting on inclines without the need for the rider to balance the motorcycle with the throttle and brake.

Riding pleasure with regard to the basic brake system means direct response of the brake with a characteristic for the hand brake lever braking effect and deceleration that is adapted to the motorcycle characteristics. The rider expects a direct reaction of the motorcycle to his wish to brake.

Besides this, additional functions can also increase riding pleasure. These include functions that increase comfort (see above), as well as functions that reduce the number of actuating elements required to achieve a braking effect corresponding to the riding situation. Generally, however, riding pleasure means evoking emotions when riding, emotions which make the overall riding experience enjoyable.

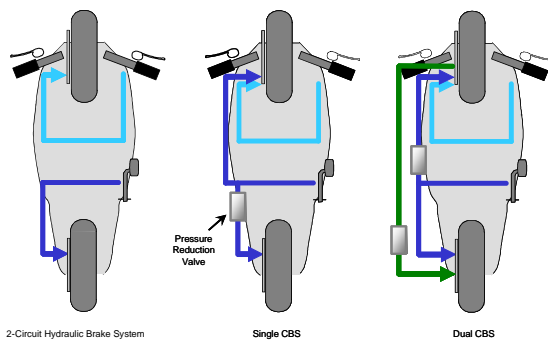
The desire for safety is paramount with motorcycles, even more so than with cars, since the consequences can be much more grave if a critical riding situation arises and a fall results. Even if the (possibly even subconscious or repressed) willingness of motorcycle riders to take a risk is greater than that of car drivers, the number of traffic deaths is the subject of increasing public criticism. The percentage of motorcycle traffic deaths among the total number of traffic deaths is comparatively high when the number of miles driven is taken into consideration. As a result, the active and passive safety of motorcycle riders must be continuously improved in the future as well. Here, ABS will increase in significance, since this system is capable of maintaining the stability of the vehicle, thus preventing a fall and an uncontrolled collision of a motorcycle rider with an obstacle. Maintaining stability is, therefore, the primary goal. Even if a collision cannot be avoided, ABS reduces the energy of the impact and provides a more favorable position for a collision since the rider remains sitting upright.

It is also important to achieve short braking distances, since reduction of the collision speed can also lessen the consequences of an accident, and this is also supported by such a system.

The operating principles of brake systems and the functional possibilities of various design forms are described below in order to show the resultant requirements and possibilities from a technical point of view.

## System Principles of Motorcycle ABS Brake Systems

**Hydraulic Brake Systems** - The system principles of motorcycle brake systems can also be understood as describing the evolution of these systems. Beginning with a 2-circuit brake system (Figure 1), in which the rider creates hydraulic pressure, for example by depressing a hand brake lever, which is transferred to the front wheel brake via hydraulic lines, and is then converted into braking force applied to the wheel. The same applies to actuation of the foot brake lever (or second hand brake lever). Nowadays, disk brakes are primarily used in brake systems. Such brake systems are technically sophisticated and are employed in a variety of ways, but without additional measures they do not live up to the requirements placed on modern brake systems for motorcycles with regard to the avoidance of wheel lockup. The rider must self modulate the pressure in the brake system in order to achieve a short braking distance. This means that build up of braking pressure at the front wheel must be as quickly as possible in accordance with the ideal braking force distribution, without causing the wheel to lock up. At the same time, braking pressure must also be built up as quickly as possible on the rear wheel, but must also be reduced again during braking due to the dynamic shift in the center of gravity.



**Figure 1. Principles of Hydraulic Brake Systems.**

This is the only behavior that ensures a short braking distance while simultaneously maintaining the stability of the motorcycle.

In general, however, a motorcycle rider is completely overtaxed by such a requirement, especially in emergency situations. This either leads to the vehicle not being decelerated ideally (the pressure build-up is either too weak, too late or too low), or the wheels are over-braked, i.e. they lock up, which by definition endangers the stability of the vehicle and usually leads to a fall.

In order to ensure nearly ideal brake force distribution between the front and rear wheels,

motorcycles are available on the market with so-called CBS systems (Combined Brake Systems). These systems are available in 2 versions:

- Single CBS, in which the hand control acts on the front wheel and the foot control (or the second hand control) acts on the front and rear wheels. This allows relatively high rates of deceleration to be achieved by actuating only one of the control elements.

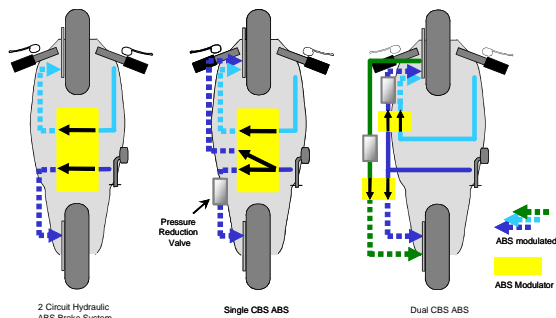
- Dual CBS, in which both wheels are braked by actuation of the hand and foot brake levers.

The hydraulics of such systems are relatively complex, since a floating front caliper with an additionally connected actuating cylinder (so-called secondary cylinder) is required in both systems. This is responsible for pressure build-up on the rear wheel. However, this configuration also requires an additional hydraulic connection from the front wheel caliper to the rear wheel caliper. In addition, the front wheel caliper is divided hydraulically (e.g. 5 pistons connected with the hand control, 1 piston connected with the foot brake), which also has a decisive influence on the cost of the overall system. Pressure limitation on the front and rear wheels in accordance with a desired brake force distribution is achieved by augmenting these brake systems by pressure limiters or brake force control valves.

**Hydraulic ABS Brake Systems** - Preventing wheel lockup and thus maintaining stability can be ensured only by a system that actively modulates the brake pressure, i.e. a system which reduces the braking pressure in certain situations, so that the wheel can be released to accelerate again if a lockup threatens, thereby maintaining lateral stability. Such anti-lock brake systems (ABS) have been available for passenger cars since their introduction in 1978. Since then, they are considered a key element in active safety, the mandatory ACEA self-commitment for new cars on the European market to have ABS has taken effect since 2004.

The first motorcycle ABS system was introduced in 1988 on a BMW K100LT, and it has been gaining recognition in the motorcycle segment since then. It is an undisputed fact that preventing lockup of the wheels ensures the stability of the vehicle, thus significantly reducing the consequences of accidents or preventing them in the first place.

In a dual-circuit brake system (Figure 2), the ABS is positioned between the control and the wheel brake. It detects the motion of the wheels in each hydraulic circuit via wheel speed sensors. The system recognizes if the rotational speed drops disproportionately quickly during a braking operation, and the braking pressure is reduced again via valve outlet action.



**Figure 2. Principles of ABS Brake Systems.**

When the wheel has nearly reached the reference speed of the vehicle again, the braking pressure is increased once more in order to continue decelerating the vehicle.

The principle is similar for a single CBS-ABS system, except that there is an additional modulator circuit on the front wheel due to the connection of the rear wheel control. Such systems require a total of 3 control channels which can be regulated independently of one another.

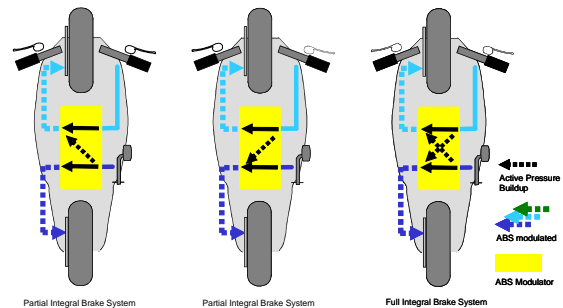
Dual CBS-ABS is characterized by the fact that the dual CBS brake system mentioned above is supplemented by ABS modulators. Here, a total of 4 control channels are needed, since one channel is required in each case for regulating the brake pressure from the hand lever to the front wheel, from the foot brake to the front wheel and to rear wheel, and from the secondary cylinder on the front wheel to the rear wheel.

In addition, there are also systems on the market that have an integrated boost function for the CBS-ABS function. These systems are designed to reduce the actuation force in order to increase comfort when braking. In this case, the hydraulic circuits of the operating elements are separated from the wheel brakes. A hydraulic pump is activated for each actuation, even in the case of partial braking, so that pressure can be built up in the wheel brake cylinder.

#### Electro hydraulic Integral Brake Systems -

Pure ABS systems are operated passively, since they cannot build up braking pressure autonomously. However, systems are known from the automotive sector that are capable of building up pressure on the individual wheels actively.

Such systems are used for Electronic Stability Control (ESC). This principle is utilized for motorcycles in developing electronic integral brake systems. Like single CBS systems, the devices can initially be systems that build up pressure on the front wheel brake when the rider actuates the foot control lever. This is a partial integral brake system which acts in forward direction. Analogously, a partial integral system acting to the rear can also be implemented, where pressure is applied to the rear wheel via an electrically controlled pump each time the hand brake lever is actuated.



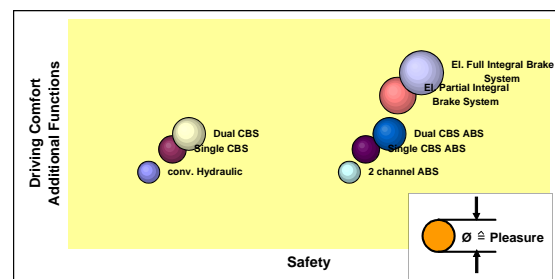
**Figure 3. Principles of Electronic Integral Brake Systems.**

If the brakes are always applied to both wheels when a brake control is actuated, this is called a full integral brake system. The design principle of this system means that it is capable of actively building up pressure on both wheels. As a result, several additional functions can be realized for applying pressure to the brakes depending on the riding situation, as well as in conjunction with other control devices.

The 2-channel ABS system, rear-acting partial integral brake system, and full integral brake systems are described in detail below.

#### Functional Potential of Different Brake Systems -

The categorization mentioned in the introduction according to comfort, riding pleasure and safety can be used to outline the possibilities of the respective brake systems (Figure 4). This categorization is, however, heavily dependent on the vehicle or type of rider. A cruiser rider will most certainly evaluate comfort criteria differently than the rider of a sports machine. In addition, the details are also dependent on the philosophy of each individual motorcycle manufacturer. Nonetheless, an attempt will be made here to evaluate the above-mentioned systems generally with regard to riding comfort and pleasure and especially to safety.



**Figure 4. Potential of Different Brake Systems.**

Based on conventional hydraulics, increased riding safety initially means greater deceleration when both wheels are braked by operation of control, or a reduction in the tendency of a wheel to lock up for a given deceleration. The wheel lockup tendency is reduced by way of the predefined brake force

distribution. This was essentially achieved with the introduction of the CBS systems.

Brake systems experienced a large increase in safety with the introduction of 2-channel ABS systems. These systems significantly improve the stability of the motorcycle during a braking operation and reduce the frequency of falls. As with the CBS systems without ABS, the safety potential is increased via the fixed, preset brake force distribution of the CBS systems. Electronic integral brake systems are able to shorten the braking distance once again thanks to the electric brake force distribution, which also means an increase in safety.

Riding comfort can be improved, for example, through use of hydraulic integral brake systems such as CBS. High deceleration is achieved by actuation of a control and, depending on the system, pitching is reduced at the same time. If additional functions are counted towards riding comfort, electronic integral brake systems allow functions to be implemented that make operation easier for the rider. Several of these additional functions will be described below.

Riding pleasure is the variable that is most difficult to define, and it is the one that is most dependent on the personal preferences of a motorcycle rider or the manufacturer's philosophy. It is primarily associated with emotions that the motorcycle rider experiences. In terms of the basic brake, this corresponds to a brake that responds directly with a clearly reproducible pressure point on the hand brake lever and therefore reflects the deceleration characteristic. This was positively influenced by the introduction of CBS and CBS-ABS systems, since pitching of the motorcycle is reduced and relatively high deceleration can be achieved with pressure build-up at one control.

With the aid of the electronic integral brake system, however, the functions can also be adapted to the specific requirements of motorcycle manufacturers and the end customer in much greater detail, thus also increasing riding pleasure.

### Functional Principles of Electro hydraulic Brake Systems with Valve Control

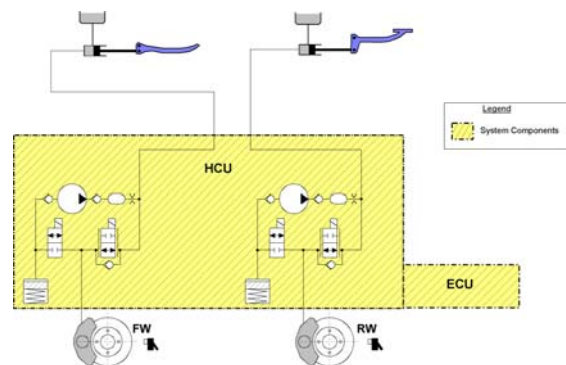
**2-Channel ABS System** - In this HECU (Hydraulic-Electronic Control Unit), two valves (an inlet valve and an outlet valve) per wheel circuit are responsible for modulation of the braking pressure at the wheel (Figure 5).

If ABS is activated, the inlet valve ensures that the actuating cylinder is hydraulically separated from the wheel brake. The outlet valve is opened in order to allow the hydraulic volume in the wheel brake to escape into the low pressure accumulator, thus reducing the braking force and allowing the wheel to reaccelerate. Once the wheel has reached the reference speed of the vehicle again, the outlet

valve is closed and the inlet valve is reopened, so that the rider can again build up brake pressure at the wheel.

A hydraulic pump sucks the hydraulic volume out of the low pressure accumulator and feeds the actuating cylinder. The rider perceives the continuous build up and release of pressure as pulsation in the controls, informing him that ABS is active. The rider therefore is aware that he is at the brake-slip threshold.

The inlet valve is designed in such a manner that it is open in de-energized state, i.e. the hydraulic pressure is directed towards the brake. The outlet valve is closed when de-energized. If the ECU fails, the hydraulic pressure of the brake cylinder is therefore routed directly to the wheel brake, and the rider is notified of this by a warning lamp in the cockpit display.



**Figure 5. Motorcycle Anti-lock Brake System (MAB) System Diagram.**

Rotation of the wheels is detected by wheel speed sensors on the front and rear wheels. In addition, the ECU is connected to the on-board 12 V supply, in order to provide the HECU with the required power. The ECU may also control cockpit warning lamps. Connection to the CAN network is possible in order to communicate the status of the ABS system, internal signals or other dynamic riding variables to other control devices.

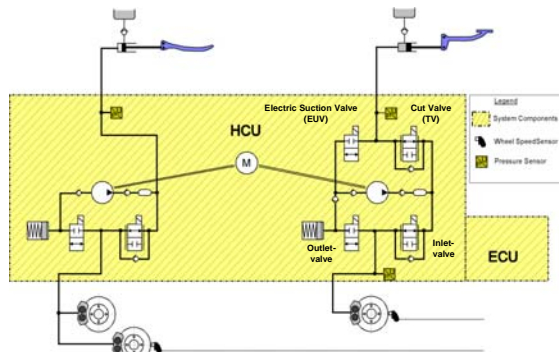
### **MIB MK 1-3 Partial Integral Brake System** -

In addition to the functionality of a pure ABS system, an integral brake system can actively build up braking pressure on the wheels without the rider having to operate the corresponding controls (Figure 6).

A special design variant is the partial integral brake system, in which the braking pressure is actively built up at the rear only. This means that an integral function is realized from the hand brake lever to the rear wheel with such a system.

A partial integral brake system consists in total of 6 hydraulic valves, two for the front wheel circuit, four for the rear wheel circuit, 3 pressure sensors, one low pressure accumulator and one hydraulic pump per wheel circuit and an ECU (Electronic

Control Unit). The two pumps of each wheel circuit are both driven by an electric motor.



**Figure 6. Motorcycle Integral Brake System (MIB) Partial Integral Brake Function.**

If the rider actuates the hand brake lever, the pressure is hydraulically applied to the front wheel brake. At the same time, the pressure sensor measures the pressure increase and sends this information to the ECU. The pump motor is controlled in accordance with preset characteristics, operating modes or other characteristic variables. To actively build up pressure at the rear wheel, the cut valve (TV-HR) is closed and the suction valve (EUV-HR) is opened. Then the pump sucks brake fluid out of the reservoir and builds up pressure in the rear brake caliper.

If the rider additionally activates the foot brake lever, the suction valve is closed once again the wheel braking pressure is attained, and the cut valve is reopened, so that the rider has direct intervention from the foot pedal to the rear wheel brake once more.

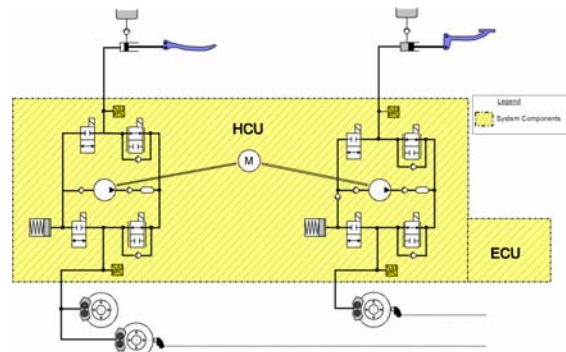
The transitions represent a particular challenge in this respect. The goal is to design the transitions in such a manner that the rider hardly perceives any feedback in the foot lever. This is possible with a balanced design of the hydraulics and the control software.

The front wheel circuit is designed as an ABS circuit with regard to the valve configuration. Only the pressure of the front wheel is modulated if the front wheel threatens to lock up during a braking operation.

Three solenoid valves (inlet valves on the front and rear wheels and block valve on the rear wheel) are designed as analog valves in order to achieve highly precise pressure modulation. This leads to exact adjustment of the pressure at the wheels and also to a reduction in the force feedback at the controls, thereby significantly improving comfort.

**MIB MK 1-4 Full Integral Brake System** - In addition to the functionality of the partial integral brake system (which acts to the rear), the full integral brake system also offers the possibility of actively building up pressure at the front wheel. This is realized by using two additional solenoid

valves and a pressure sensor to complement the front wheel circuit (Figure 7).



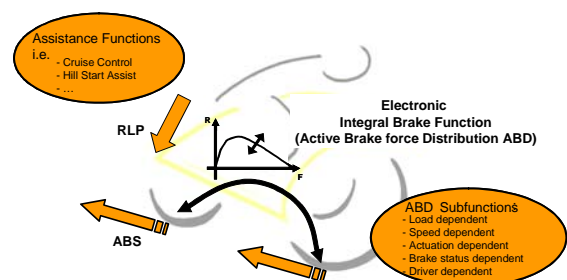
**Figure 7. Motorcycle Integral Brake System (MIB) Full Integral Brake Function.**

The functionality is similar to that of the partial integral brake system, except that additionally the rider input is also measured at the rear wheel control. Braking pressure can also be built up at the front wheel corresponding to the riding conditions and desired function.

The possibilities of realizing additional functions with such systems are described below.

### Overview of the Most Important Functions

The functional basis of the motorcycle integral brake system is the anti-lock function of the ABS system (Figure 8). The goal of this safety function is to maximize utilization of the friction coefficient potential between the motorcycle tire and the road in order to prevent lockup. Especially with motorcycles, a front wheel lockup of more than several hundred milliseconds with the resultant loss of stability and a subsequent fall can have fatal consequences.



**Figure 8. Motorcycle Integral Brake System (MIB) Function Overview.**

Rear Wheel Lift-Off Protection (RLP) is indispensable for most motorcycles as a functional supplement to ABS for the vertical dynamics of the motorcycle. Here, the goal is to ensure a stabilizing remaining load for the rear wheel in order to prevent a flip. The heart of the MIB system is the electronic integral braking function with Active Brake force Distribution (ABD) for distributing the

rider's braking command to the basic brakes at the front and rear. In the case of the partial integral brake, active brake pressure generation can be functionally applied at the rear wheel due to the hand lever being actuated (ABD front to rear) or the brake pressure can be adjusted at the front wheel due to the foot lever being actuated (ABD rear to front). The full integral brake system incorporates both partial functions. Overall, ABD is variable depending on the load, vehicle speed, actuation characteristics and the two actuating controls.

There is also the possibility of providing adjustment options for the individual rider.

Assistant functionalities can be integrated thanks to the possibility of changing or generating brake pressure in an interaction with the motorcycle rider. Cruise control including brake intervention and hill start assist are only a few examples of such functions.

**Rear Wheel Lift-Off Protection (RLP) -**

When the brakes are fully applied, there is a major dynamic wheel load displacement from the rear to the front wheel. Depending on the motorcycle design or the rider position, the rear wheel may lift off as a result (Figure 9).



**Figure 9. Motorcycle Integral Brake System (MIB) Rear wheel Lift-off Protection.**

The loss of wheel contact force on the rear wheel not only results in an early lockup tendency, but also very imprecise handling of the motorcycle when braking. Experienced riders compensate for this by removing braking pressure from the front wheel or performing a “stoppie”.

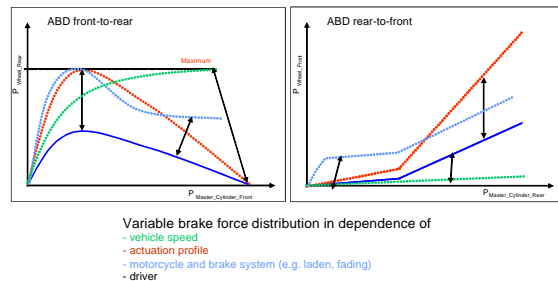
However, there is a high risk of a flip in the case of a rapidly executed panic stop with the associated high dynamic forces acting around the transversal axis. RLP prevents this, thus taking the fear of fully applying the brakes from the rider.

RLP compares the wheel speed signals and the derived signals of both wheels during the braking operation. In addition, the pressure information of the individual control circuits is processed to determine a lift-off tendency. The pressure control algorithm of the front wheel reduces the braking pressure below the ABS limit in such a way that a minimum wheel contact force is maintained. This eliminates the risk of a flip while simultaneously maintaining ideal deceleration.

**Active Brake force Distribution (ABD) -**

ABD is responsible for the appropriate distribution of the rider's braking command to both wheels. This is carried out in interaction with the brake pressure directly applied by the rider hydraulically via the two actuating controls, whereby the individual distributions, from the hand lever to the rear wheel and from the foot lever to the front wheel are realized using software (Figure 10).

The basic characteristic can be based on the ideal braking force distribution and then adapted to suit the situation. Here, input variables such as vehicle speed, as well as signals that describe the rider braking profile are used. This means, for example, that the influence of the rear wheel brake can be reduced at very low speeds in order to achieve ideal handling.



**Figure 10. Motorcycle Integral Brake System (MIB), Active Brake force Distribution (ABD).**

Additional possibilities for influencing the brake force distribution are the detected load change and brake state changes such as fading. The rider is also provided with the possibility of customizing the motorcycle by switching between different modes using preset tuning options.

**Hill Start Assist (HSA) -**

The rider is required to perform complex operations using a wide variety of operating controls particularly when stopping and starting on steep gradients or off-road. The stopping operation is made more difficult in situations where locking the front wheel with the hand lever is not sufficient to prevent the motorcycle from rolling/sliding away due to the incline. Here, the foot brake also needs to be used.

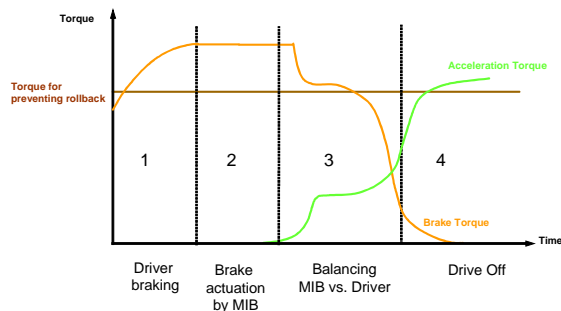
With MIB it is possible to significantly relieve the rider's workload for operation of motorcycle via the HSA function. The system assists the rider in stopping and starting, so he can concentrate on more important, higher priority tasks.

If the rider brings the motorcycle to a stop on an uphill slope, the HSA function freezes the required brake pressure at the wheels (Figure 11). The hydraulic configurations of a partial integral brake suffice for this, while the full integral brake offers the most comprehensive set of options.

The rider can now release the brake controls and observe the surrounding traffic, and MIB keeps the



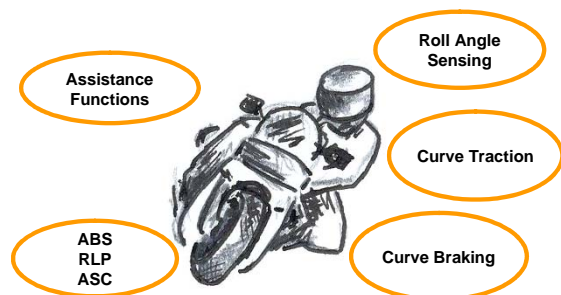
motorcycle stationary on the incline. All that is needed to start is the application of the clutch and throttle. Enough residual pressure remains in the brakes to prevent roll-back as long as the engine power is insufficient for safe acceleration.



**Figure 11. Motorcycle Integral Brake System (MIB) Hill Start Assist (HSA).**

## CONCLUSION

With MIB, the necessary basis has been created for integrating additional safety functions beyond the basic functions of ABS and RLP, and for improving the performance of the existing functionality. A variety of assistant functions will continue to relieve the rider, as in passenger cars, and increase riding safety in the future. First examples have already demonstrated this.



**Figure 12. Motorcycle Integral Brake System (MIB) Outlook.**

Additionally, sensitive sensors that better describe the riding dynamics of motorcycles extend the possibilities for safe use of traction control systems (Figure 12). Here too, the first steps towards enhanced safety in cornering situations have recently been taken by integrating the information from roll angle sensors into the control systems.

## REFERENCES

Hoffman, O., Eckert, A., Woywod, J. "The Motorcycle Integral Brakesystem MIB: an advanced brake solution for high performance motorcycles", 6. Internationale Motorradkonferenz, Köln, 9.-10.10.2006

# TECHNICAL BASES FOR THE DEVELOPMENT OF A TEST STANDARD FOR IMPACTS OF POWERED TWO-WHEELERS ON ROADSIDE BARRIERS

**Steffen Peldschus**

**Erich Schuller**

Ludwig-Maximilians University

**Jens Koenig**

**Marcus Gaertner**

DEKRA Automobil GmbH

Germany

**David García Ruiz**

CIDAUT

**Alberto Mansilla**

Universidad de Valladolid

Spain

Paper Number 07-0332

## ABSTRACT

The problem of injuries to motorcyclists caused by impacts on roadside barriers has numerously been pointed out in the literature. Nevertheless, there is a lack of agreement concerning injury criteria for these particular cases. One of the objectives of the European research project APROSYS SP4 "Motorcycle Accidents" is to propose a European crash test standard for the assessment of impact performance of roadside barriers with respect to injury risks. This paper describes the methodology of work that has been followed for the proposal of the standard.

In-depth databases have been analysed in order to evaluate the nature of motorcyclists' impacts to barriers and to gain knowledge in addition to the anecdotal cases reported in the literature. About 1000 accidents of powered two-wheelers from four different databases were analysed. In contrast to previous views, impacts in upright riding position seem to occur equally often as impacts in sliding position. A detailed analysis of the current testing procedures (e.g. the Spanish standard, the procedure developed by INRETS, France) has been performed. Full-scale crash tests in sliding position, performed by CIDAUT, and upright position, performed by DEKRA, were included in this analysis. The selection of the injury criteria, especially in head, neck and thorax, has to take into consideration the peculiarities of this kind of accidents. It was concluded that the biofidelity of available dummies (Hybrid III) needs to be further assessed for this particular application, e.g. by comparative simulations using HUMOS2 model.

The knowledge gained at the light of the results obtained from the described methodology will be used in the future development of a standard.

## INTRODUCTION

Road infrastructure is of particular importance for accidents of powered two-wheelers (PTW). This is not only due to the potential involvement in the accident causation, but occupants of PTW can, unlike those of other vehicles, easily establish direct contact with the road infrastructure in the course of an accident.

Most of the previous work on this topic has focused on roadside crash barriers as an impact obstacle. It is widely acknowledged that these barriers constitute a particular hazard to motorcyclists once they have fallen, although there are controversial opinions on this topic as for example stated in [Otte et al, 1986] where the importance of injuries caused by guardrail impacts was considered to be rather low, with 1.9 % of all injuries in an analysis of 379 motorcycle accidents in the Hannover region (Germany).

A widely followed approach to reduce potential injury hazards is to prevent contact with geometries that could potentially concentrate impact forces on the human body. This idea led for instance to the development of additional lower rails and of absorbing envelopes for the metal barrier posts. Several test procedures have been developed in order to assess the efficacy of such countermeasures. Within the European research project APROSYS SP4 "Motorcycle Accidents" a crash test standard for Europe will be proposed. This paper describes the methodology followed for this work.

Representative impact conditions have to be known and biofidelic dummies with associated injury criteria for these particular impacts are needed for the development of a crash test proposal. Therefore

in-depth databases have been analysed in order to evaluate the nature of motorcyclists' impacts to barriers and to gain knowledge in addition to the anecdotal cases reported in the literature. In addition, existing testing procedures were reviewed including the analysis of full-scale crash tests performed by CIDAUT and DEKRA.

## ACCIDENT ANALYSIS

### Accident Data Sources

For the analysis of in-depth data performed in the APROSYS SP4 project [Peldschus 2005] several in-depth databases were available within the consortium: the DEKRA database and the GIDAS data of 2002 (Germany), the data of the COST 327 project (Finland, UK, Germany), and the Dutch part of the MAIDS database.

**GIDAS 2002** – GIDAS stands for “German In-Depth Accident Study” which is being carried out by two independent teams. The Hannover team is sponsored by BAST (Federal Highway Research Institute) while an industry consortium under the auspices of VDA/FAT is financing a second investigation team at the Technical University of Dresden. Both teams share a common data structure and the cases are stored in a single database. A random sampling scheme was introduced in August 1984 and is still in use. So 1985 is the first year for which this database can be considered representative of the German national statistics. Accidents are investigated at-scene using blue-light response vehicles. In most cases extensive photo documentation is also available. The data covers the accident situation, participants (including cars, motorcycles, pedestrians/cyclists, trucks, buses, trams, trains), accident cause, injury cause, human factors and vehicle technologies. The qualifying criteria are that:

- the road accident resulted in at least one person being injured.
- the accident occurred within specified regions around Hannover or Dresden.
- the accident occurred while the team was on duty (2 six-hour shifts per day, alternating on a weekly basis).

Approximately 2,000 new accident cases are investigated each year. The GIDAS 2002 dataset which was analysed for the several tasks within this work was purchased from DEKRA and relates to 230 powered two-wheelers and 248 PTW users.

**COST 327** – The European Co-operation in the Field of Scientific and Technical Research (COST) 327 was formed to investigate head and neck injuries suffered by motorcyclists by carrying out a comprehensive and detailed analysis. The COST 327 accident database consists of 253 cases collected from July 1996 to June 1998 in the UK by the Southern General Hospital, Glasgow, in

Germany by the Medical School of Hannover and Munich University (LMU) and in Finland by the Road Accident Investigation Team. All cases are characterised by the following criteria:

- a powered two-wheeler was involved.
- a full or open face helmet was worn.
- head/neck injuries of AIS 1 or above were suffered - or known head/helmet contact without head injuries occurred.

**DEKRA Accident Database** – The fundamental basis of the DEKRA accident databases is the accumulation of written expert opinions containing the accident analyses that are drawn up by skilled forensic experts at the DEKRA branches throughout Germany and totalling about 25,000 annually. The particular feature of these reports is that generally the experts are called by the police or prosecuting attorney to come to the accident scene directly after the accident happened. The DEKRA experts have to answer case specific questions in their expert opinions. Therefore they have the right to determine the accident circumstances, which includes, if necessary, a detailed technical inspection of the involved vehicles. The DEKRA experts operate all over Germany on a 24hour/7day week basis. Thus, the nearly 500 DEKRA accident experts have the opportunity to attain all the information necessary for their task. The reports provide a substantial basis for accident research work. The DEKRA Accident Research & Crash Test Center has the opportunity to select and analyse interesting cases, which normally consist of the written expert opinions, detailed accident reconstructions, sketches and photo material. Sometimes single injuries are described but by and large only the general injury severity is stated. The actual DEKRA PTW database comprises 350 cases from 1996 to 2005 with all kinds of other vehicles as well as single PTW accidents. About 300 parameters per accident are reviewed when using the DEKRA questionnaires. Since expert opinions are normally commissioned only when the accident is of a really serious nature, the main focus of the PTW database is on accidents resulting in severely or fatally injured occupants. These accidents happen mostly in rural areas and involve high speeds. Therefore, the outcome of each accident and the relevant impact velocities have to be interpreted under the circumstances mentioned above.

**Dutch MAIDS Data Set** – In order to better understand the nature and causes of PTW accidents, the Association of European Motorcycle Manufacturers (ACEM) with the support of the European Commission and other partners conducted an extensive in-depth study of motorcycle and moped accidents during the period 1999-2000. Sampling was carried out in five areas located in France, Germany, Netherlands, Spain and Italy, resulting in a large PTW accident

database called after the MAIDS (Motorcycle Accident In Depth Study) project. The methodology developed by the Organisation for Economic Co-operation and Development (OECD) for on-scene in-depth motorcycle accident investigations was used by all five research groups in order to maintain consistency in the data collected in each sampling area. A total of 921 accidents was investigated in detail, resulting in approximately 2,000 variables being coded for each accident. The investigation included:

- a full reconstruction of the accident
- detailed inspection of vehicles
- interviews with accident witnesses
- collection of factual medical records relating to the injured riders and passengers. These were subject to the applicable privacy laws and were obtained with the full cooperation and consent of both the injured person and the local authorities.

The in-depth data gathered in the Netherlands by TNO are part of the MAIDS database. In this segment of the database 200 accidents were investigated and coded. The accidents incorporated were PTW accidents in the Haaglanden region (The Hague, Rotterdam), in which a police alert was sent to the Dutch accident research team. The coverage was over 90 % of all PTW accidents in the region.

### Findings in the Database Analysis

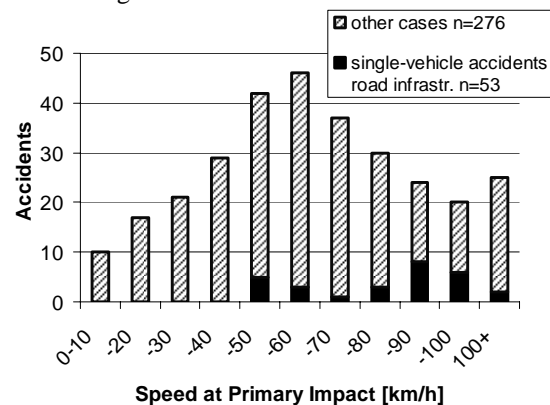
Due to very different data and inclusion criteria of the several databases results can only be given for each database separately. In addition, the queries for the analysis had to be adapted to each database specifically.

The impact velocities for accidents involving contact with road infrastructure were analysed. The impact speed could not be exactly determined for the actual impacts at the object of interest from some databases. Therefore the primary impact speed was analysed. Some uncertainty remains for the accidents which involved further impacts to other objects.

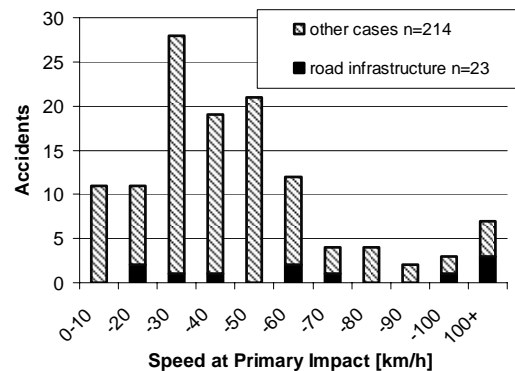
The median primary impact speed for accidents involving impacts to road infrastructure was above 50km/h for all the four databases. Figure 1 and 2 give the distribution of impact speeds for the DEKRA data and the GIDAS data, respectively. These figures show the quite different overall distribution of impact speeds between the two databases. The numbers of relevant cases within the COST data and the Dutch MAIDS data were small with 16 and 4, respectively.

Only the GIDAS data contained information on the road-leaving angle, i.e. the angle between the velocity vector of the powered two-wheeler and the road tangent. In case a roadside barrier was installed next to the road, this angle would be

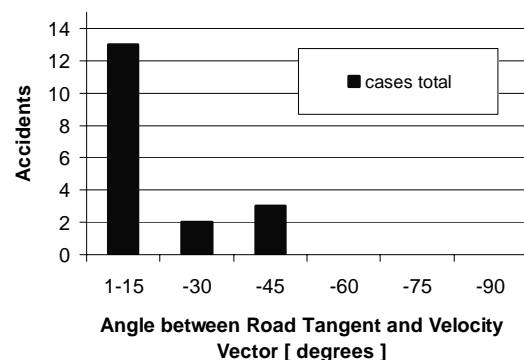
approximately the impact angle. Figure 3 shows the distribution within different angle ranges. This supports the observations found in the literature, that impacts to roadside barriers usually involve shallow angles.



**Figure 1. Impact speed for accidents involving impacts to road infrastructure compared to all other cases (DEKRA data).**



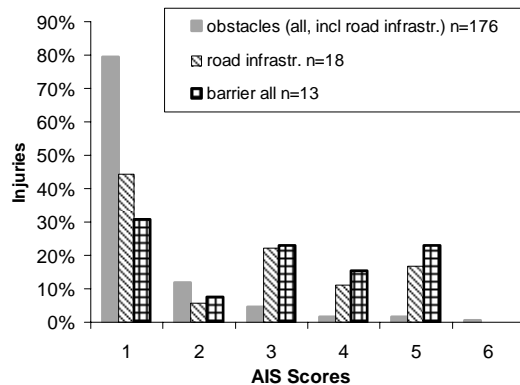
**Figure 2. Impact speed for accidents involving impacts to road infrastructure compared to all other cases (GIDAS 2002 data).**



**Figure 3. Road leaving angle (GIDAS 2002 data).**

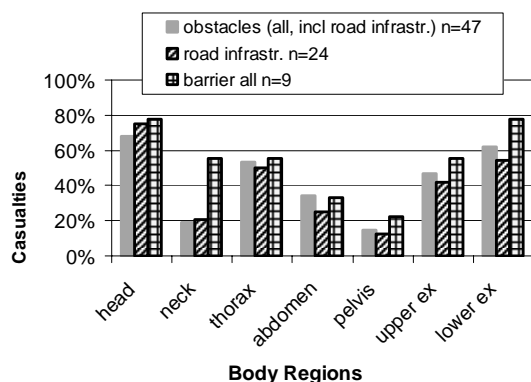
The GIDAS and the COST data allowed an analysis of injuries and the objects that had caused them. Figure 4 shows the severity of injuries caused by impacts to different groups of obstacles. Injuries caused by obstacles in general were predominantly of AIS1 score. However, looking at injuries caused

by road infrastructure or barriers, a shift towards higher AIS scores can be observed.



**Figure 4. Severity of injuries caused by different groups of obstacles (GIDAS 2002 data).**

Figure 5 gives the location of the injuries that were caused by impacts to obstacles in general, road infrastructure and roadside barriers. The most commonly injured body regions are the head and the lower extremities, followed by the thorax and the upper extremities. There was a high incidence of neck injuries caused by barrier impacts. The number of cases is small however, and this result could also be related to the inclusion criteria of the COST database.



**Figure 5. Location of injuries caused by different groups of obstacles (COST 327 data).**

The position of the rider with respect to the powered two-wheeler at the time of impact to an obstacle was analysed in the manner of a single-case analysis for the DEKRA, COST and Dutch MAIDS data. This analysis included impacts to trees and poles as well as to roadside barriers. The results are given in table 1. In most of the cases, for which the constellation could be determined, the occupant impacted the obstacle still being on his vehicle, with the powered two-wheeler in an upright position.

In summary, high velocities (above 50km/h), shallow impact angles and upright riding position as well as sliding after separation from the PTW

seem to constitute typical impact scenarios for road infrastructure and similar obstacles. Even if the incidence of such impacts is not high, the problem appears to be of importance as related injuries are severe. Head, thorax and lower extremities seem to be most commonly injured by such impacts.

**Table 1. Position of occupant with respect to PTW at time of impact (tree/pole/barrier, cases counted)**

	DEKRA	COST	Dutch MAIDS
Separated	5	6	1
Not separated, upright	19	14	9
Not separated, sliding	2	0	0

## CRASH TESTING

### Analysed Crash Test Procedures

Three different procedures, which were seen to be suitable in order to represent the above-mentioned accident impact conditions, were analysed.

**DEKRA Tests** - The analysed DEKRA crash tests were carried out within a research project [Gaertner et al 2006] by order of the German Federal Highway Research Institute (BAST). This included impact tests of occupant and powered two-wheeler in two different configurations. The aim of this project in continuation of a previous one [Buerkle and Berg 2001] was to develop a new, motorcyclist-friendly safety barrier which can easily and with reasonable efforts be adopted to already existing barriers in Germany. Two main issues have been worked out to define a motorcyclist-friendly safety barrier. The contact of a motorcyclist in upright riding position with sharp edges and injurious parts of the upper safety barrier has to be prevented as well as the impact of a sliding motorcyclist against the barrier posts. Many efforts had been undertaken for the development of devices to prevent a sliding motorcyclist from severe or fatal injuries by impact to barrier posts. The risks in an upright impact have been identified but there were no practicable solutions available to adopt to existing barriers. Therefore new solutions had to be designed and tested.

An MATD (Motorcyclist Anthropometric Test Device) Dummy was used. This dummy has been especially designed for the multiple movements and loads at motorcyclists' impacts. The MATD is equipped with 9 uni-axial instead of one tri-axial acceleration sensor in a Hybrid III. Therefore the MATD-Dummy would also allow measurement of the rotational accelerations of an impacting head. In

the neck the moments and forces in all 3 directions are measured. Four tackle-potentiometer in the chest measure the intrusion for the upper and lower chest area in x and y-direction as well as the upper and lower intrusion velocity. The sensors of the femur measure forces and torque. The femur itself is made out of fiber-reinforced plastics and can break if a certain force level is exceeded. Shear pins and elastic plastic elements in the knee reproduce the twisting of the knee. The tibias are also breakable and are equipped with sensors that measure the forces and moments in all 3 dimensions. In total, the MATD dummy was equipped with 66 measurement channels in the head, neck, chest, pelvis, femurs and tibias. The motorcycle recorded acceleration data with two tri-axial acceleration sensors in the front and rear frame – a total of 6 channels.

The first of the two impact configurations is depicted in figure 6. The initial velocity of the motorcycle leaving the sledge was 60 km/h and the impact angle was 25°.

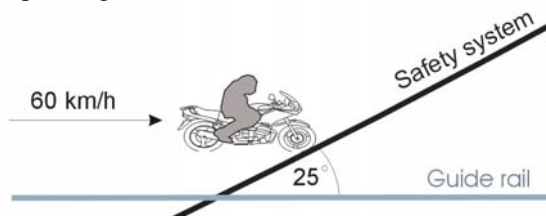


Figure 6. Parameters inclined impact.

Figure 7 shows the sled that was used for this impact configuration. It is in principle the same as used in the second configuration but with an additional device which is mounted. This device enables an inclination of 45° which initiates the tumble of the dummy and the motorcycle.

Some loads of the test are displayed in Table 2. To distinguish the data between actual contact with the system and loads that are due to the fall on the ground, the data was divided into primary and secondary data. This separation into primary and secondary data is necessary because the impact of the head against the ground results in a very high peak in the acceleration data. This would otherwise modify the evaluation of the protection potential of the barrier system. At the test displayed in Table 2 head contact with the ground occurred during secondary data recording – resulting in a very high peak of 101 g's. But the significant values that show the performance of the safety system appear during primary data recording.

The second of the two impact configurations was in purely upright position of the occupant and the motorcycle. Like in the first impact tests the initial velocity of the sledge was 60 km/h. The angle between the velocity vector of the impacting

motorcycle and the safety system was elaborated to 12° – Figure 8.



Figure 7. Test sled inclined impact with dummy and motorcycle.

Table 2. MATD data of the inclined test

	limit	primary	%**	secondary	%**
<b>Head</b>					
a <sub>res</sub> 3ms	80 g	33,2	42	101	127
HIC <sub>36</sub> ms	1000	69,0	7	584	58
<b>Neck</b>					
M <sub>b y</sub>	57 Nm	11,5	20	18	31
F <sub>x</sub> max	3100 N	175,8	6	243	8
F <sub>z</sub> max	4000 N	31,6	1	1283	32
<b>Chest</b>					
a <sub>res</sub> 3ms	60 g	11	19	9	16
<b>Pelvis</b>					
a <sub>res</sub> 3ms	60 g	12	20	14	24
<b>Femur</b>					
F <sub>z</sub> right max	9070 N	-2764	30	776	9
F <sub>z</sub> left max	9070 N	401	4	-774	9

\*: neg. values = compression, pos. values = tension

\*\*: % of the limit

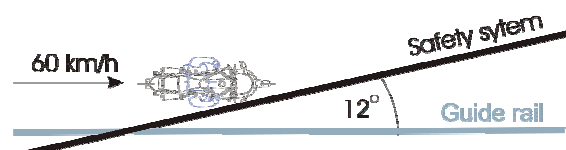


Figure 8. Parameters upright impact.

Figure 9 shows the sled with the mounted motorcycle and the dummy. A motion sequence of both impact configurations is depicted in figure 10.

Some loads of the upright test are displayed in Table 3. The separation into primary and secondary data can roughly be seen in Figure 10 right column. Secondary data begins at the last picture sequence just when the dummy has left the guard rail. The data collected until this point is primary data. Data after this point – including head impact on the ground – is secondary data.



Figure 9. Test sled upright impact with dummy and motorcycle.



Figure 10. Motion sequence of inclined and upright crash test.

Table 3.  
MATD data of the upright test

	limit	primary	%	secondary	%
<b>Head</b>					
a <sub>res 3ms</sub>	80 g	10	13	84	106
HIC <sub>36 ms</sub>	1000	5	1	383	38
<b>Neck</b>					
M <sub>b y</sub>	57 Nm	26	45	56	98
F <sub>x max</sub>	3100 N	144	5	317	10
F <sub>z max</sub>	4000 N	391	10	3406	85
<b>Chest</b>					
a <sub>res 3ms</sub>	60 g	13	21	51	85
<b>Pelvis</b>					
a <sub>res 3ms</sub>	60 g	18	30	12	20
<b>Femur</b>					
F <sub>z right max</sub>	9070 N	-6744	74	-590	7
F <sub>z left max</sub>	9070 N	-2960	33	-815	9

\*: neg. values = compression, pos. values = tension  
\*\*: % of the limit

**INRETS/LIER Procedure** – The procedure has been defined based on an accidentology study performed by the LIER laboratory of INRETS [Bouquet et al 1998, Quincy 1998] in 1995 through the medical investigation of 230 motorcyclists involved in accidents in the region of Lyon. Although the quantity of cases is high, the disadvantage of this study is that the information contained in this study concerns all type of motorcyclist accidents, not only collisions against barriers.

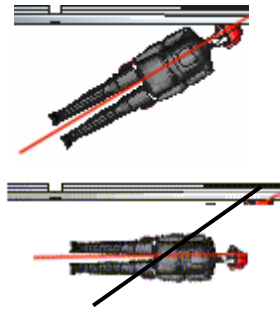
The consideration that LIER has taken for the test definition is that when a motorcyclist has an accident in a curve, the vehicle skids and the motorcyclist falls. After that, the motorcyclist slips on the roadway following a nearly rectilinear trajectory, runs off the roadway and impacts against a post of the barrier. The variables ‘impact angle’ and ‘impact speed’ are complementary, in the sense that, a greater impact angle can compensate for a reduction of impact speed. Also, the definition of LIER test is based on ‘impact angle’ detailed in the study by Cayet and Godge [Cayet and Godge 1978]. LIER took into account the two mentioned studies and technical aspects such as the impossibility of throwing a dummy with a small impact angle, because it is pursued that head be the only part of the body impacting the barrier. Considering these limitations, the final LIER test consists on throwing a dummy against the metal barrier with an impact angle of 30° as shown in figure 11) with the dummy lying on its back and with the head towards the barrier.

From the accidentology analysis, two test configurations were identified:

- Configuration 30°: the motorcyclist is launched against the safety device (guardrail) lying

down with the back on the floor and the head in the impact direction, describing a trajectory that forms a 30° angle (tolerance 0.5°) with the barrier.

- Configuration 0°: the motorcyclist is launched against the safety device describing a 30° angle trajectory. However, in this case, the body is parallel to the barrier to be tested and so the dummy will impact with the shoulder, the arm and the head.



**Figure 11. Impact configuration LIER tests.**

In the LIER test, the ‘motorcyclist’s impact speed’ used is 60 km/h, which could be associated with a travelling speed equal to 80 km/h. The main problem in the dummy selection to perform the test is that there is not a specifically designed dummy for this type of test and it is necessary to make modifications from a standard dummy. The dummy selected by LIER for performing the tests was an assembly of elements coming from other dummies. This dummy comprised:

- Hybrid II thorax, limbs and shoulders,
- a pelvis of pedestrian kit in order to give it an articulate standing position,
- Hybrid III Head and Neck allowing measures of accelerations, forces and moments,
- motorcyclist equipment: suit, glove, boots and helmet.

The biomechanical criteria that are applied as limits to pass the test are given in table 4. These focus on head and neck. No value is defined for the lateral flexion (Mx) although this parameter is also measured to be used as an indicative and comparative index between the different systems tested. All the measured curves were filtered with 1000Hz.

**Table 4. Biomechanical criteria used in LIER tests**

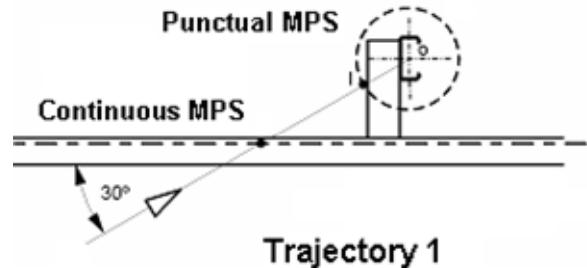
Measurement	Biomechanical limit	Filter class
Resultant head acceleration	220 g	CFC 1000
HIC	1000	CFC 1000
Neck flexional moment	190 Nm	CFC 1000
Neck extension moment	57 Nm	CFC 1000

It was reported that parts of the dummy fractured in the impact tests. The failed part was usually the clavicle. It was therefore suggested to improve the design of the Hybrid II in order to better withstand lateral loading.

**Spanish Standard** – In 2005, the Spanish standard (UNE 135900) ‘The assessment of motorcyclists’ protection systems performance situated in safety roadside barriers and pretils was defined by CIDAUT under requirements of the Spanish Transport Ministry (Ministerio de Fomento) [CIDAUT 2005]. The purpose of this standard is to define the methods that allow evaluating the behaviour of the motorcyclist protection systems (MPS), punctual as well as continuous ones.

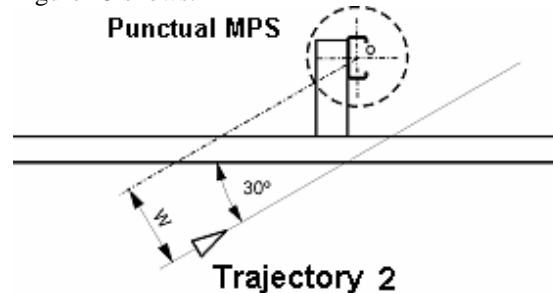
Depending on the kind of system to be tested, a different trajectory is chosen:

- Trajectory 1 – Centred post impact: Applicable to punctual and continuous MPS with an approaching angle equal to 30°, as the Figure 12 shows.

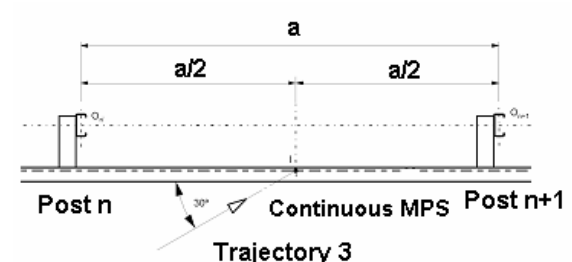


**Figure 12. Trajectory 1.**

- Trajectory 2: Excentric post impact: Applicable only to punctual MPS. It is the horizontal line that goes at a distance ‘W’ of the center of masses of the post, with an approaching angle equal to 30°, as the Figure 13 shows.



**Figure 13. Trajectory 2.**



**Figure 14. Trajectory 3**



- Trajectory 3: Centred rail impact: Applicable only to continuous MPS (figure 14).

The main objective of the roadside barriers is to redirect the motorcyclist into the road but very close to the barrier. The roadside barriers should have the appropriate stiffness to achieve this objective. A very high stiffness barrier can cause serious injuries of an impacting motorcyclist. On the other hand, a very compliant barrier could absorb a lot of energy but also allow the rider to override the upper rail of the system. To assess this issue, a rail-centred impact has to be performed (figure 14). A very compliant lower rail can also lead to a severe contact of the motorcyclist with the post in trajectory 1 (figure 12), which is actually to be prevented by the MPS.

The Spanish standard defines the impact speed of 60 km/h as the impact speed for the all three possible trajectories detailed in the standard for punctual (PS) and continuous (CS) motorcycle protective systems (MPS). Taking into account the three trajectories, the launching position is defined as depicted in figure 15, where the dummy spine axis coincides with the approximation trajectory.



**Figure 15. Trajectory and dummy position.**

As LIER specified, the variables ‘impact angle’ and ‘impact speed’ are complementary, and this Spanish standard tries to cover the worst situation.

The requirements of this procedure are that the dummy (motorcyclist) should travel sliding on the floor by itself, separated from the motorcycle, and hit the protection system to be tested, with a specific entrance angle and speed. Once a test is performed, the conclusions about the behavior of a specific protection device are obtained taking into account the severity level defined from the combination of biomechanical severity indexes that appear determined in the report. Though this report of standard tries to give some guidelines in order to identify whether a motorcyclist protection system is valid or not, every motorcyclist protection device installed in a safety crash barrier or pretil and every crash barrier or pretil especially designed to improve motorcyclists protection, have to guarantee that it does not affect in a negative way in the

performance when impacted by road vehicles (according to EN 1317-2).

The dummy is to be equipped with an integral helmet that should comply with the requirements of Regulation ECE R22. The dummy will be equipped with a leather motorcyclist suit of thickness from 1mm to 1,5mm, complying with the Standard UNE-EN 1621. For performing tests, the dummy shall be a Hybrid III 50th Percentile Male, equipped with a kit pedestrian that allows a standing position. The following measurements are to be taken for the evaluation of the impact severity:

- HEAD: HIC36
- NECK: Fx, Fy, Fz, Mx, My

In order to measure the head accelerations a three-axe sensor should be installed in the Hybrid III head centre of gravity and in order to measure the neck forces, a load six-axe cell should be used, 3 channels for measuring the forces and the other three for the moments. The twist moment is measured but it is not used in the acceptance criteria.

The first part of the acceptance criteria of the impact test is the behavior of the safety device. No element from the crash safety barrier or pretil weighting 2Kg or more should result separated from the device unless that is necessary for its correct performance. The working width and dynamic deflection of the device with the dummy impact should not be in any case equal or higher than those defined by the Standard UNE EN 1317-2 for a vehicle impact. The behavior of the dummy is the second part of the acceptance criteria. The dummy used for the test should not have intrusions, dummy breakage except the clavicle, result beheaded or suffer any dismemberment. On the other hand, the dummy clothing (general equipment) should not result cut. Finally, the dummy should not get hooked by any part of the safety device.

By courtesy of HIASA, an example of an impact test passed with level I result (best level) according to the Spanish standard is shown in figures 16 and 17.

Table 5 gives the according measurement results for this test together with the maximum accepted values, according to the better of two different types of protection levels.



Figure 16. Test side view.

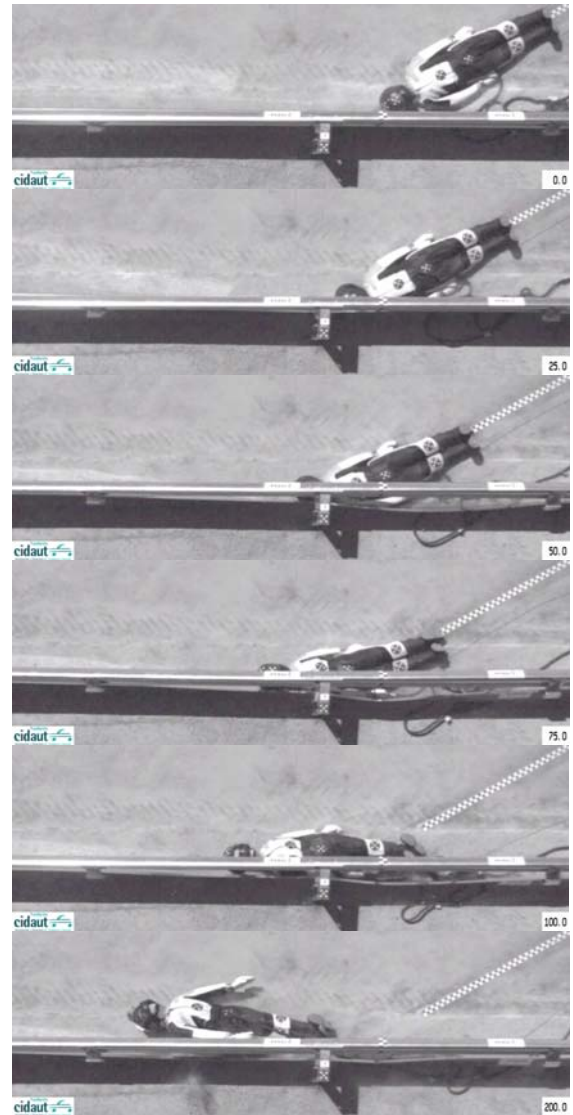


Figure 17. Test top view.

**Table 5.**  
**Test results and acceptance limits for sliding barrier impact**

	Test results	Limit Level I
HIC 36	107.16	650
Fx	Appendix A	Appendix A
Fz traction	Appendix B	Appendix B
Fz compression	Appendix C	Appendix C
Mxc	75.63	134 Nm
Myc flexion	42.75	190 Nm
Myc extension	37.26	42 Nm
Working width	0.41	EN1317 m

### Injury Criteria and Biofidelity

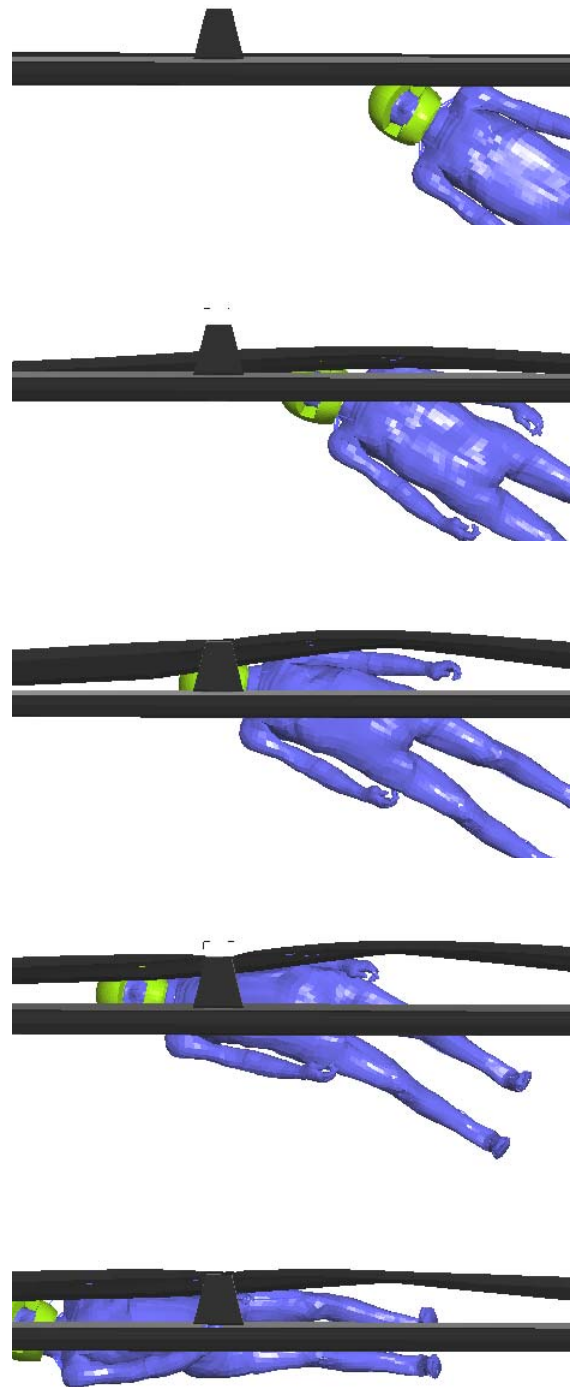
Different injury criteria have been encountered in existing crash test procedures. Those have mostly been transferred from other kinds of crash tests, which leads to the question of the suitability of the used dummies and the validity of the injury criteria. Accident reconstruction and PMHS testing would

be necessary in order to properly investigate relevant injury mechanisms and to establish valid injury criteria. The in-depth accident data analysis described in this paper did not provide single cases suitable for reconstruction of both the course of the accident and the injury causation. On the other hand, only one report [Schueler et al. 1984] on PMHS testing in this field - focusing on upper extremities - can be found in the literature.

The analysis of the full-scale crash testing may however serve to identify some potential for further improvements in biofidelity and injury criteria. The results of the tests performed by DEKRA suggest to consider the extremities in more detail. Particularly the second impact configuration, in purely upright position, potentially involves high injury risks for the upper and lower extremities. The upper extremities can be caught in the parts at the top of the barrier (like spacers), while the lower extremities can be clamped between the motorcycle and the barrier. Even if impacts and injuries to the extremities are not as threatening as those to other parts of the body, they may greatly influence the kinematics of the rider and this in turn influences the overall injury outcome and the protection potential of a barrier system.

The tests in sliding impact position performed by CIDAUT demonstrate that the shoulder and the arm establish contact to the barrier post through the lower rail. This leads to the question whether the thorax is remarkably loaded in such an impact. In the light of the lack of suitable data and investigation methods, a preliminary numerical crash simulation with a human model was applied to gain insight into this problem.

**Simulation with Human Model** – The PAMCrash HUMOS2 model has been validated for lateral thorax loading [Merten 2006] and it has been demonstrated to depict injury mechanisms in motorcyclists' impacts to roadside barriers [Peldschus & Schuller 2006]. The sequence of the simulation given in figure 18 shows an impact as in the test of figure 17 with a similar barrier model provided by HIASA. In this simulation the deflections of the impacted half of the thorax were measured according to the methodology presented in [Kuppa et al. 2003]. The maximum deflections at 50% of the half circumference of the thorax at the height of rib 4 and rib 8 were 51mm and 48mm, respectively. These results indicate a risk for severe thoracical injuries caused by lateral loading in such an impact. It is therefore suggested to include injury criteria for lateral thorax loading in a test procedure of sliding barrier impact.



**Figure 18. Impact simulation with human model (steps of 25ms).**

**Implications for Dummy Modification** – The Hybrid III dummy was designed for frontal impact testing. The only measurement, that can be taken to assess lateral loading with a reasonable effort, is equipping the dummy with a sensor to measure lateral acceleration at Th4. However, as the dummy is not biofidelic in lateral loading, the measurement results may be misleading. As a first step to improve the biofidelity for a sliding impact of a motorcyclist into a barrier it is proposed to use a frangible shoulder as depicted in figure 19. Apart from the possible improvement of the biofidelity, some of the components of a Hybrid III dummy may not fully comply with the strong load requirements in lateral tests. An irreparable and costly fracture of the dummy shoulder has not only been reported for the LIER tests as stated above. Also Buerkle and Berg [Buerkle and Berg 2001] reported such a shoulder fracture. The Spanish impact standard described above considers such a modified shoulder for the Hybrid III. Inertial moments and weight are not changed significantly from the original dummy and its failure is aiming at reproducing that of a clavicle in the human body.



**Figure 19. Frangible shoulder/clavicle.**

## CONCLUSIONS AND RECOMMENDATIONS

The results of the in-depth data analysis suggest that impacts of motorcyclists into roadside barriers typically occur at speeds above 50 km/h under shallow angles. At the time of impact the rider seems to be more often on its PTW in upright position than sliding on the ground after separation from the motorcycle. Injury mechanisms and the establishment of related injury criteria remain an issue to be investigated in more detail. For this purpose, more in-depth accident data would be needed. First studies on full-scale crash testing including the motorcycle have been performed, but future efforts should concentrate more on this issue than the work performed so far in the field of PTW and roadside barriers. Concerning the impact in sliding position an additional measurement for lateral loading of the thorax is suggested. This should however be introduced in combination with a modification of the dummy shoulder, which is

also proposed in terms of durability. The results of this study will be used for the development of a standard for sliding impact within the APROSYS SP4 project. Similar efforts on upright impact, including the PTW, should be undertaken in the future.

## ACKNOWLEDGEMENTS

The authors would like to acknowledge the support of HIASA and the ESI Group. Part of this work was funded by the European Commission within the APROSYS project under the 6<sup>th</sup> Framework Programme.

## REFERENCES

- Bouquet, R., Ramet, M., Dejamme, M. 1998. "Protocole d'essais de dispositifs de retenue assurant la sécurité des motocyclistes." Report LBSU N°9807 for LIER/INRETS.
- Buerkle H. and Berg F. A. 2001. "Anprallversuche mit Motorrädern an passiven Schutzeinrichtungen. Berichte der Bundesanstalt für Straßenwesen", Reihe Verkehrstechnik, Heft V90, Verlag Neue Wissenschaft GmbH, Bremerhaven
- Cayet J.C. and Godde Ch. 1978. "Conditions de choc sur glissière de sécurité survenues sur autoroutes"; Rapport ONSER.
- CIDAUT Fundación para la Investigación y Desarrollo en Automoción. 2005. UNE 135900-1 report. Final report for the assessment of motorcyclists' protection systems performance situated in safety roadside barriers and pretails.
- Gärtner M., Rücker P., Berg F.A. 2006. "Entwicklung und Prüfung der Anforderungen an Schutzeinrichtungen zur Verbesserung der Sicherheit von Motorradfahrern", Reihe Verkehrstechnik, Heft 940, Verlag Neue Wissenschaft GmbH, Bremerhaven.
- Kuppa, S.; Eppinger, R. H.; McKoy, F., Nguyen, T.; Pintar, F. A. ; Yoganandan, N. 2003. "Development of Side Impact Thoracic Injury Criteria and Their Application to the Modified ES-2 Dummy with Rib Extensions (ES-2re)". In: *Stapp Car Crash Journal* 47. SAE, 189 – 210.
- Merten, K. von, 2006. "Using HUMOS2 model for the reconstruction of accidents with thoracical injuries". In *Journal of Biomechanics* 39, supplement 1, 165.
- Otte, D., Suren, E., Appel, H. 1986. "Leitplankenverletzungen bei motorisierten Zweiradbenutzern." In *Zeitschrift fuer*

Verkehrssicherheit, Nr 32/3, Verlag TUEV Rheinland GmbH, Koeln.

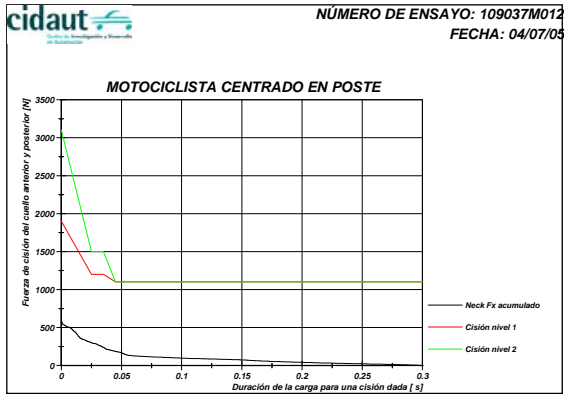
Peldschus, S., 2005. "APROSYS SP4.1: Report on accident scenarios for motorcycle-motorcyclist-infrastructure interaction. State-of-the-art. Future research guidelines". Deliverable 4.1.3. AP-SP41-0003

Peldschus, S. and Schuller, E. 2006. "Simulation of motorcyclists` impacts on roadside barriers using a numerical human model" In Proceedings of the 6<sup>th</sup> International Motorcycle Conference (Cologne). Ifz research publications.

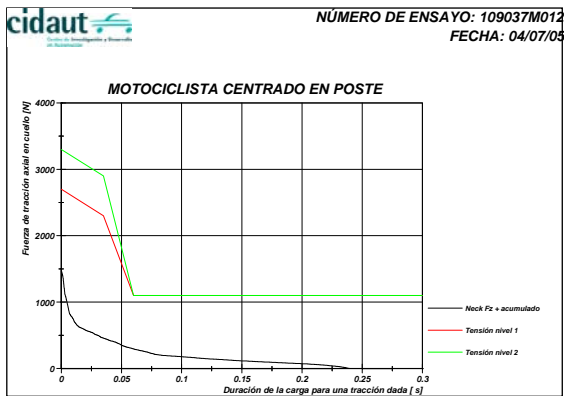
Quincy R. 1998. "Protocole d'essais de dispositif de retenue assurant la securite des motocyclistes", Laboratoire d'essais Inrets Equipments de la Route (LIER).

Schueler F, Bayer B, Mattern R, Helbling M, 1984. "Der Koerperanprall gegen Schutzplanken beim Verkehrsunfall motorisierter Zweiradbenutzer". Institut fuer Zweiradsicherheit, Bochum.

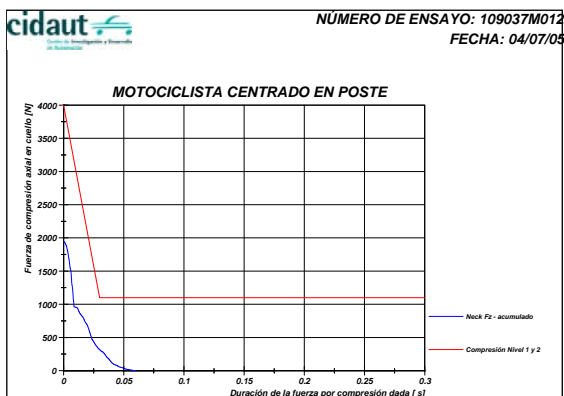
## Appendix A Fx measured on neck



## Appendix B Fz traction measured on neck



## Appendix C Fz compression measured on neck



## REAL CASES MOTORCYCLE AND RIDER RACE DATA INVESTIGATION: FALL BEHAVIOR ANALYSIS

**Vittore Cossalter**

**Andrea Aguggiari**

*Department of Mechanical Engineering  
University of Padova, Italy*

**Dirk Debus**

*2D-datarecording GmbH  
Germany*

**Alessandro Bellati**

**Andrea Ambrogi**

*Dainese S.p.A.*

*Italy*

Paper Number : 07-0342

### ABSTRACT

The need for more safety is beginning to be perceived also in the motorcycle race context, and the demand for more protective motorcycle garments is becoming more challenging. In this scenario DAINESE is working together with some racing teams for investigating new solutions to improve rider safety.

In this paper, dynamical measurements of several motorcycle crashes, recorded both on the rider and the motorcycle, will be presented and analyzed. General tendencies among the different cases and repeatability have been investigated.

The available data was collected during the 2006 MotoGp Championship, which proven to be a perfect scenario for acquiring limit-condition-driving data, and a challenging environment for testing innovative safety devices.

Although focused on the race competitions, this study should also be useful in the future for developing more general purpose rider protection systems.

### INTRODUCTION

Predominantly developed for cars airbag technology is still in its first stages with regards to motorcycles. Nevertheless motorcyclists, especially on tracks, are likely to experience falls due to front slippage, rear slippage or high-side phenomena. The dynamic behavior of the motorcycle-rider system during falls is very complex, and the development of a proper rider protection system is to be considered a challenge. The possibility of utilizing the airbag technology also on motorcycles is promising, however to achieve this task numerous fall samples are needed to understand the phenomena.

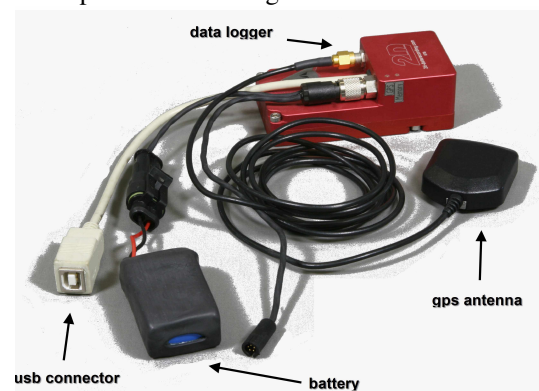
In this paper example of data recorded during real race falls are reported. A first analysis of these data have been carried out in order to understand what happens during a crash. Several crash simulations

in different computing environments [1] and real fall analysis [2] showed some guidelines in this kind of investigations. To analyze repeatability and general tendencies in race crash phenomena a campaign to collect dynamic bike-rider system data has been carried out by DAINESE during 2006 MotoGp World Championship.

### DATA COLLECTION

Thanks to the cooperation of some MotoGp racing teams and some of their riders a proper data acquisition apparatus have been installed on some rider-bike system. This led to the possibility to compare actively motorcycle and rider data with the need to place two recording systems on each motorcycle-rider assembly.

This approach has been followed because it is very difficult to understand the dynamic behaviour of a rider without the possibility of analyzing also the motorcycle data. The systems utilized for acquiring the data were 2D data-recording units specifically designed for this task. The assembly is composed of an inertial platform with three accelerometers and three gyrometers, a GPS unit able to record both speed and bank angle.



**Figure 1. Recording apparatus designed by 2D.**

The apparatus is designed to respect the requirements of the race context: it is lightweight, small, very robust. An other big advantage offered, is the widespread diffusion of the 2D software that permitted to share the acquired data with racing teams.

In Figure 2 the position of the two systems with reference to the motorcycle and the rider, is shown. The motorcycle unit was placed in the undertail, damped inside a vibration absorbent material; the rider unit was placed inside the aerodynamic appendix of the leather suit, not to impair the rider movements.



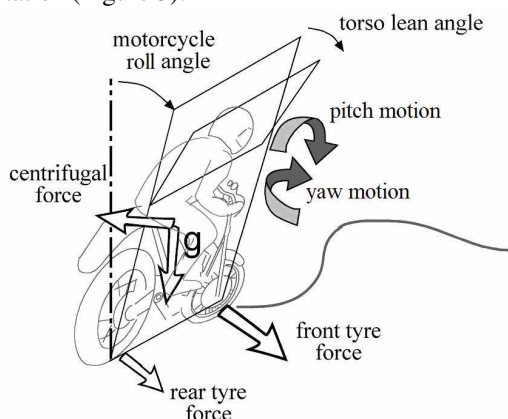
**Figure 2. Positioning of the recording systems.**

Different bikes and motorcycles were instrumented collecting data from eight riders among sixteen different circuits for both 125 and 250 displacements. These racing classes were chosen because being lower the motorcycle-rider weight ratio, and being the overall dynamic subject to faster directional changes, they could be useful for exploring the dynamic response of motorcycle and rider under limit riding conditions.

### FALL DYNAMICS

While racing, two are the more common types of fall which can be experienced: lowside and highside.

Lowside [2] [3] [4] (referring to a world fixed triad), is a yaw movement, which normally turns the bike in an over-steering rotation. From a theoretical point of view the typical lowside experienced under race conditions is caused by a uncompensated asymmetry in the distribution of the tyres forces. Once a tyre loose friction with the terrain the centrifugal force and the weight force, which are centred in the centre of gravity, create a momentum that leads the motorcycle to an sudden rotation (Figure 3).



**Figure 3. Disequilibrium in the motorcycle adherence forces during a fall.**

Due to the high inclination of the bike (over  $45^\circ$ ) the yaw moment will be recorded in the motorcycle relative triad, as GZ gyrometer (relative yaw) and GY gyrometer (relative pitch) measurements.

The second kind of typical fall, the highside [2] [3], is an impulsive oscillation around the roll axis, that can lead to a compression of the back suspension with a following upward ejection of the rider. This oscillation is normally caused by sudden lost of adherence with a subsequent traction recovery that creates a disequilibrium in the lateral forces of the tires. Typical condition in which this type of fall can happen is during curve exit, during the acceleration phase and while the motorcycle is slightly tilted. With a bigger roll angle the motorcycle could difficultly regain adherence and the fall would turn into a lowside movement. The less the traction coefficient the smaller the angle at which this fall can happen.

### STATISTICAL ANALYSIS OF DATA

Motorcycle is a vehicle intrinsically unstable, especially at low speeds. For this reason the threshold between normal dynamics and fall dynamics can be very thin; and it's difficult to distinguish between them. During races, very high degrees of rotations are experienced.

A statistical analysis can prove helpful in understanding motorcycle movements under extreme driving conditions, and to see the limits of the dynamic behavior. In Figure 4 and Figure 5, statistical trends of respectively motorcycle and rider measurements are reported. Roll angle, longitudinal and lateral accelerations, and gyrometers signals are reported, showing the probability of a certain value being recorded. A value of 1 (dark blue), indicates the most probable recorded value of the signals, where else a value of zero (white), means a never recurring value.

As it is possible to see in Figure 4 and Figure 5, roll angle values normally range from  $-50$  degrees to  $+50$  degrees, but the most typical values are the central and the extreme ones. This means that the more common positions held by a motorcycle during race competitions are the perfect straight line or the maximum roll angle reachable by the rider. This happens for speeding up the turn completion. The values reported for the roll angle, are computed using the GPS so they have to be intended in an absolute reference triad.

Same considerations can be made for the acceleration plots in Figure 4 and Figure 5: the acceleration is maximum during cornering and the more frequent values are the center value and the extreme values. Laterally the maximum acceleration reached is about  $17-18 \text{ m/s}^2$ , while for what regards the longitudinal acceleration, it's clearly visible an asymmetry between acceleration and deceleration. In particular during deceleration it's possible to reach values up to  $12 \text{ m/s}^2$ . Accelerating it's difficult to surpass  $7 \text{ m/s}^2$ , after the start of the race. It's interesting to note that high values of longitudinal acceleration, are more



frequent exiting from the corners; this happens because when the speed is low and the motorcycle is cornering; the aerodynamic drag force is also low, and so the available trust acceleration is higher. Also in this case values come from GPS measuring, so they have to be intended in an absolute reference triad.

Both in the roll angle data and in the acceleration data, it is possible to see that positive values are more frequent than negative ones (the sign depends on the reference axis used). This can be easily understood because of the direction of rotation during races; normally tracks in clock wise direction are more common than counter clock wise ones.

The GX gyrometer measurements show a distribution of values which is almost symmetrical and the higher values are reached around the value of 140km/h. The total sum of longitudinal axis rotations along a closed lap, must be zero indeed. GY gyrometer values are mostly positive because measured in a motorcycle relative triad [2]; they depend on the absolute yaw rate and the roll angle of the bike.

Looking at the GZ gyrometer measurements, it's easy to note, a shape resembling an "up pointing" arrow. As the speed rises, it becomes more difficult to realize high yaw rate turning, because the cornering radius of the trajectories become wider. The higher the forward speed the lesser the cornering yaw speed recorded by the gyrometers. Also in this case is present an asymmetry between positive and negative values; this is again explained with the prevalence of the clock wise circuits. There are not much differences between motorcycle and rider values because in normal driving conditions the rider can be considered substantially as part of the motorcycle, except for small movements. However it is possible to note some variation in the distribution of the gyrometers measurements. This is because the rider adds to the movement of the motorcycle some independent motion for better controlling the bike and keeping the equilibrium. For example, during braking the rider torso is pointing upward while at full speed is completely leaned horizontally.

### **FALL MEASUREMENTS EXAMPLES**

Coherently with what explained in the theoretical approach, Figure 6 shows what happens during a lowside. The rotational speeds are normalized with respect to a nominal value. Time dependent signals show long yaw and pitch motions, registered by the GZ and the GY sensors, while GX especially for the motorcycle mounted sensors remains shorter. When the fall starts, the motorcycle is already tilted after entering in a curve, so when the sliding motion starts, the main sensors which can record

the out of plane movements are the GY and GZ gyrometers.

In the highside in Figure 7, very high values of the GX and GZ gyrometers are recorded on the motorcycle while other gyrometer data reach lower values. This is because the tilt angle of the bike is smaller.

Similarities can be noted between motorcycle and rider recorded data. However as a first instance, there are differences between the two motions, and these become more and more evident as the fall evolves, because the movement of the rider, sliding apart, differs from motorcycle. In every different fall event there is a great deal of variation, since the rider movements can change considerably among the possible cases.

As a general tendency, during a lowside the rider starts the fall rotation movement shortly after the motorcycle; during highside is the same: the motorcycle is the first to experience the sudden rotation around the longitudinal axis. For a better graphs understanding, the peaks recorded during normal driving values are reported using a set of comparative lines.

Looking at the peak normal driving lines, in both type of fall cases it is clearly visible how different are the maximum normal driving values, with respect to fall data registered. In normal driving maximum values of gyrometers never exceed 1/8th of values registered during a sudden fall.

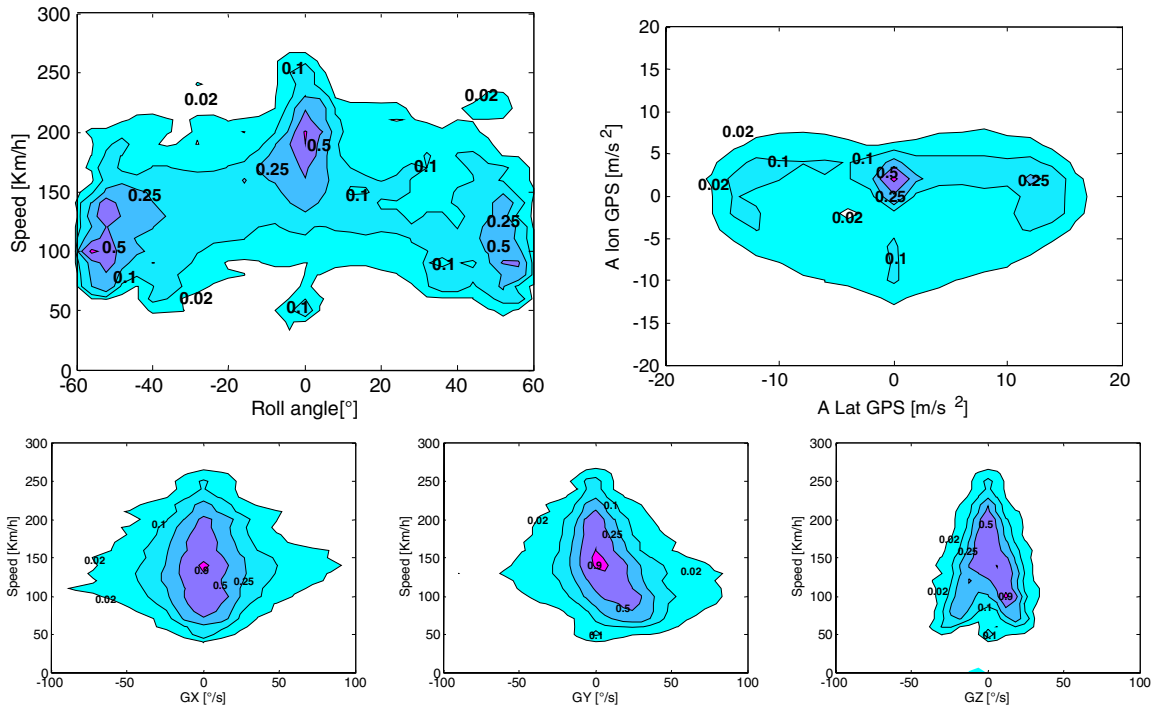
### **GENERAL TENDENCIES IN THE DIFFERENT TYPE OF FALL**

Analyzing different data from various sources, it has been searched for common lines and repeatability between the various falls.

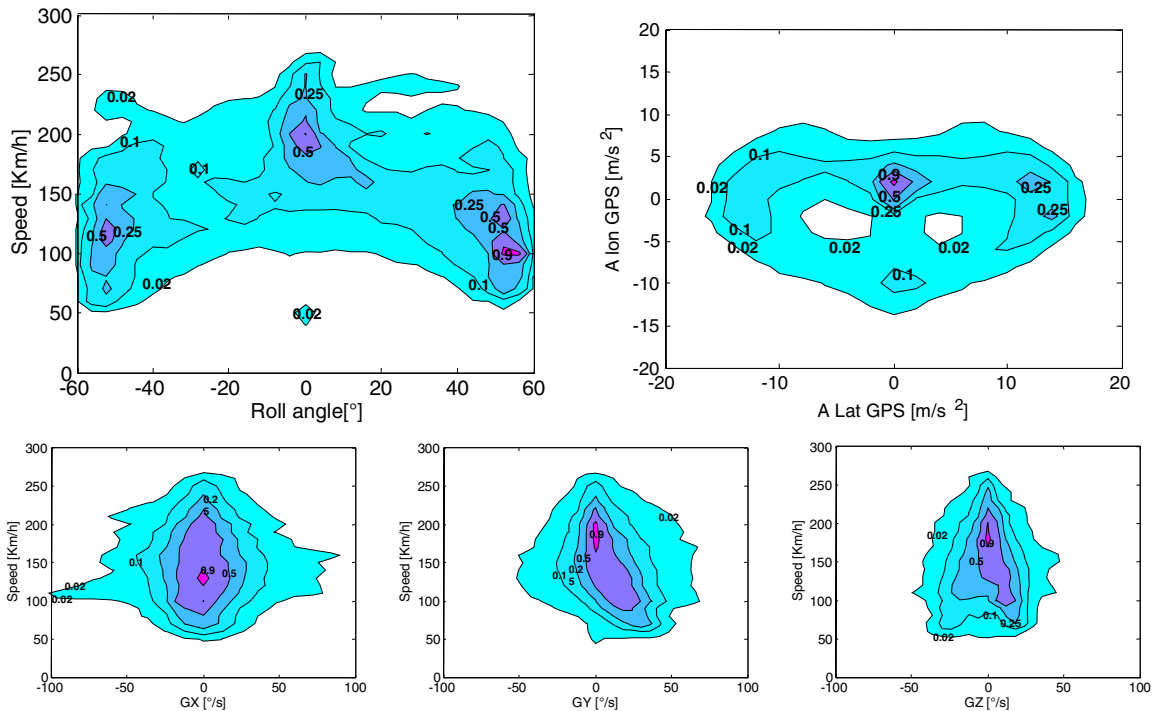
Figure 8 and Figure 9, show a correlation between maximum absolute values and RMS values recorded on the motorcycle and the rider by the three gyrometers axis among 14 different falls. Three of these falls are highside, while the other are all lowside ones.

Graphs show a possible distinction between the two types of fall; lowside tends to have lower absolute maximum and lower RMS values while highside tends to show higher values of both absolute maximum and RMS. In the lowside the rotation is progressive, in the highside instead it comes in the form of sudden burst. This difference is evident from the timings involved in the two events: in the lowside the fluctuations are longer and more progressive, while in the highside they are shorter but more powerful.

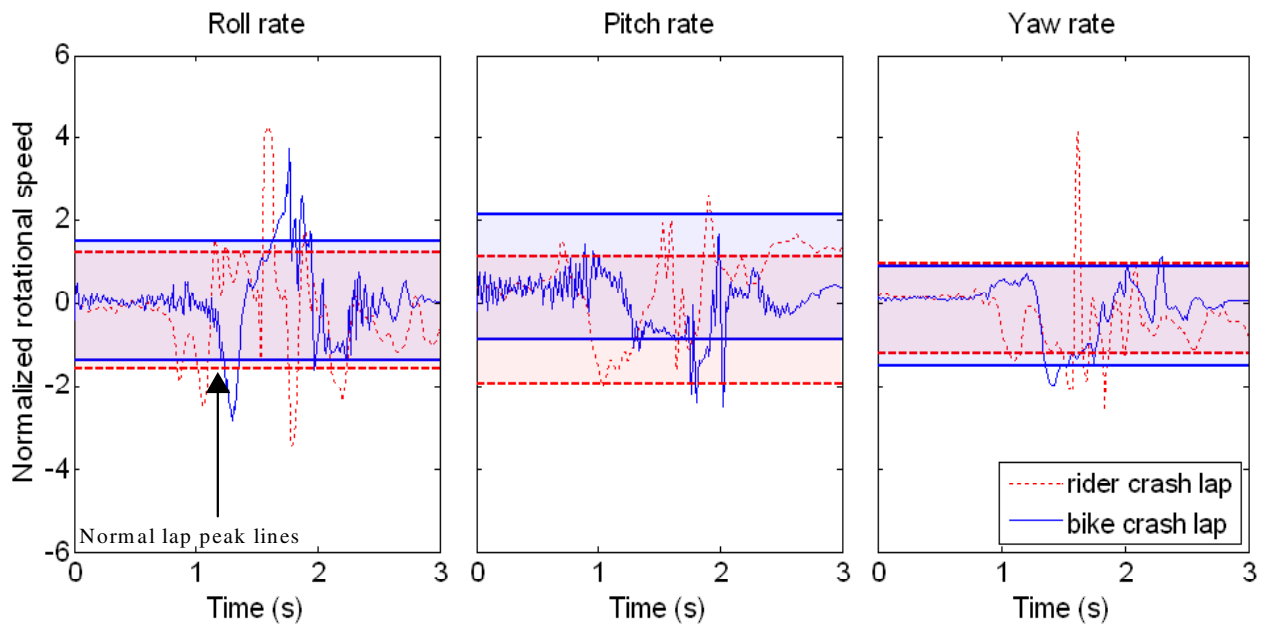
Concluding it is possible to isolate two different areas, one which identifies lowside and one for highside. This highlights the fact that even if the falls are different, there is repeatability among the fall events of the same type.



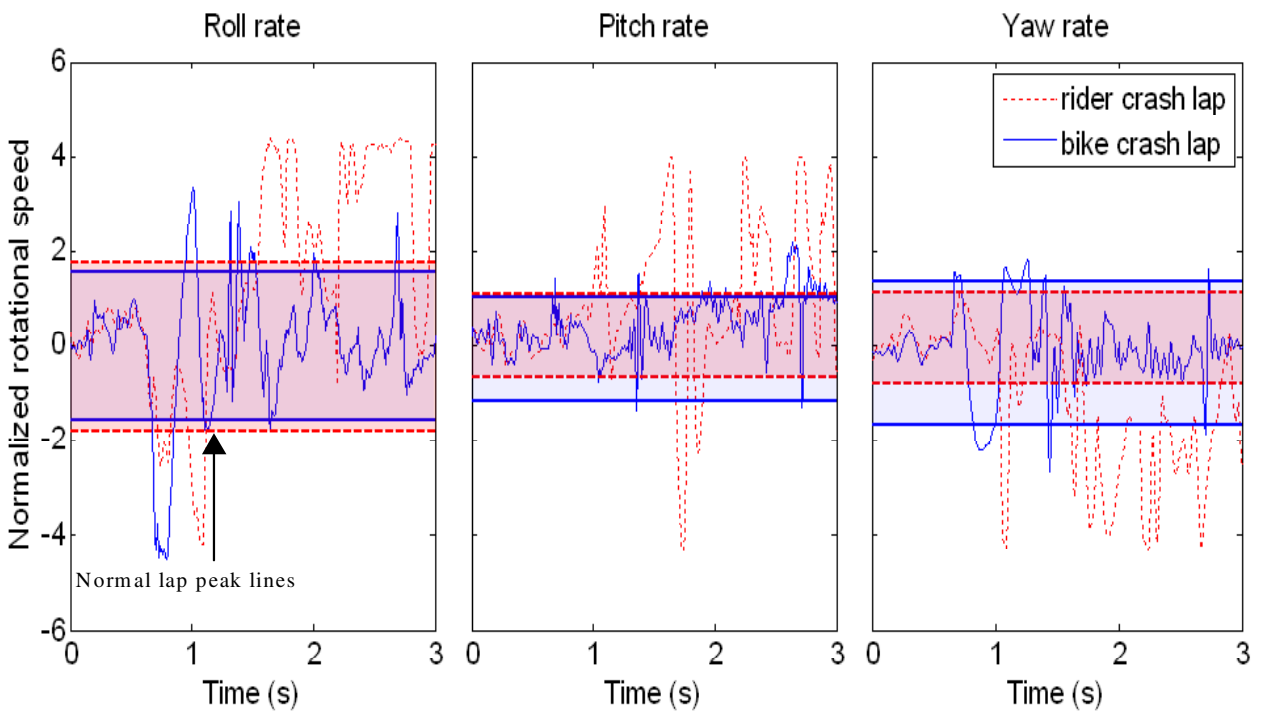
**Figure 4. Statistical frequency of the motorcycle signals: roll angle, GPS measured accelerations, GX, GY, GZ, gyrometers data.**



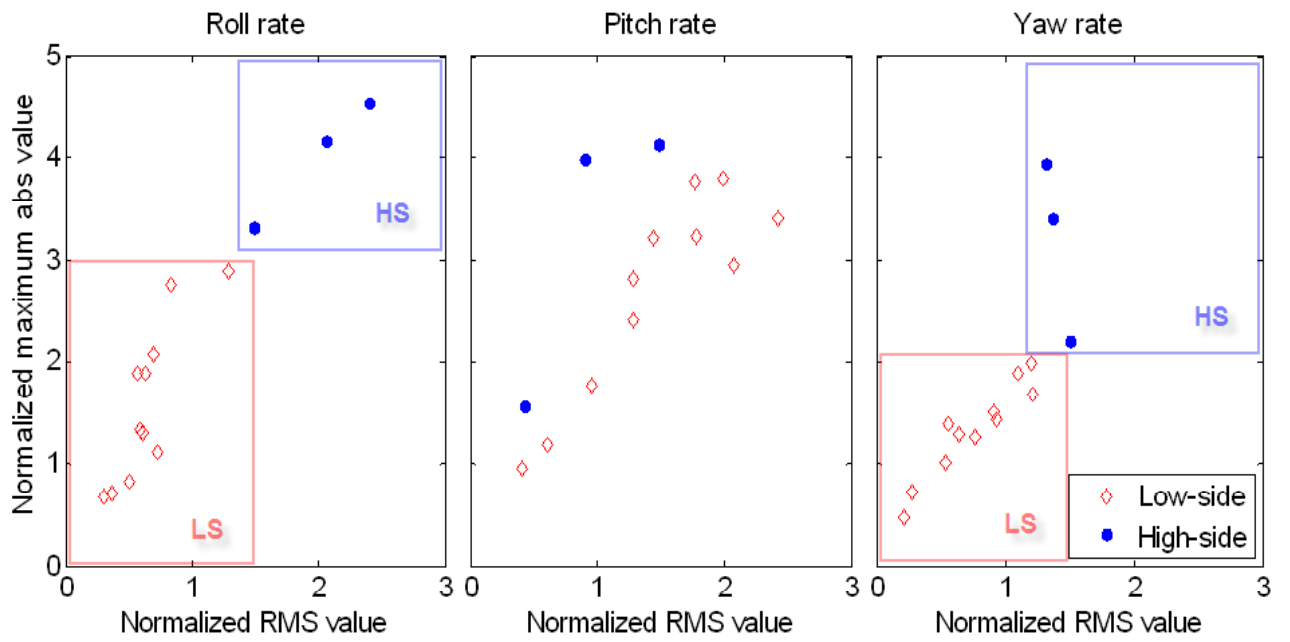
**Figure 5. Statistical frequency of the rider signals: roll angle, GPS measured accelerations, GX, GY, GZ, gyrometers data.**



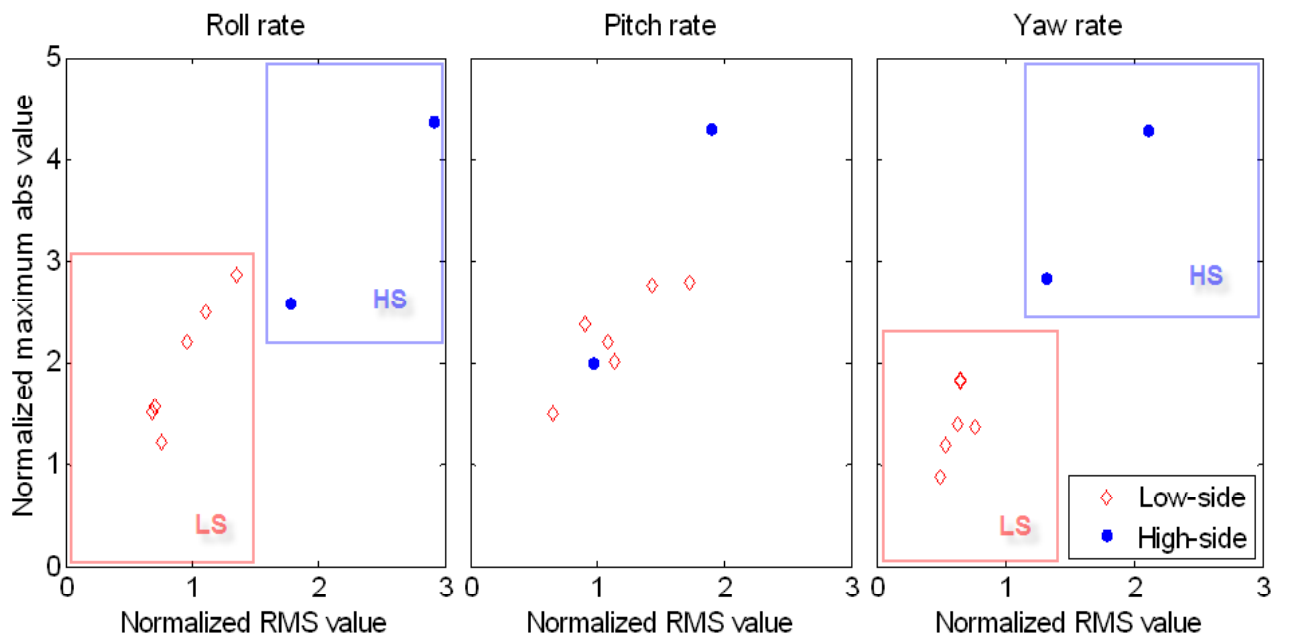
**Figure 6. Dynamic measurements of motorcycle and rider data acquired during a lowside fall.**



**Figure 7. Dynamic measurements of motorcycle and rider data acquired during a highside fall.**



**Figure 8. Distribution of the absolute maximum gyrometers values of motorcycle with respect to RMS values.**



**Figure 9. Distribution of the absolute maximum gyrometers values of rider with respect to RMS values.**

## CONCLUSIONS

Last year, a data collection campaign was carried out, and interesting dynamical data on both motorcycle and rider data were recorded during race competitions.

Example of real falls showing some similarities and differences between the rider and the motorcycle data during normal lap and crash events are presented. General tendencies and common lines in the different fall configurations are analyzed and reported.

This study aim to improve our knowledge of the dynamic behavior of motorcycle-rider system during critical conditions and furthermore to identify some parameters that could be used to improve current and future active and passive safety systems.

## ACKNOWLEDGEMENTS

Thanks to the KTM racing teams for the technical support during data acquisition.

## REFERENCES

- [1] V. Cossalter, A. Bellati, V. Cafaggi. 2005. "Exploratory Study of the Dynamic Behaviour of Motorcycle-Rider During Incipient Fall Events" Paper Number 05-0266, Proceeding of 19th International Technical Conference on the Enhanced Safety of Vehicles Conference (ESV) in Washington, D.C. 6-9 June 2005.
- [2] A. Bellati, V. Cossalter, R. Lot, A. Ambrogio. 2006. "Preliminary investigation on the dynamics of motorcycle fall behaviour: influence of a simple airbag jacket system on rider safety", Proceeding of 6th International Motorcycle Conference, IFZ Institute for Motorcycle Safety, Cologne, 9 -10 October 2006.
- [3] Cossalter, V., R. Berritta. 1999. "Analysis of the dynamic behaviour of motorcycles in dangerous manoeuvres using the multi-body code MSC Working Model." Proceeding of the 1999 High-tech Engine and Cars Conference (Modena, Italy).
- [4] Cossalter, V. 2006. " Motorcycle Dynamics", ISBN: 978-1-4303-0861-4, Publisher: Lulu.com.

# OPPORTUNITIES FOR SAFETY IMPROVEMENTS IN MOTORCYCLE CRASHES IN THE UNITED STATES

**Randa Radwan Samaha, Kazuyoshi Kuroki, Kennerly H. Digges**

George Washington University

**James V. Ouellet**

Motorcycle Accident Analysis

United States

Paper Number 07- 0370

## ABSTRACT

Given the steady growth of the crash problem since the late 1990s, a descriptive analysis of motorcycle crashes on U. S. roads was performed to gain insight into crash causation and investigate opportunities for improving rider safety. Data from the 1992-2004 National Automotive Sampling System/General Estimate System (NASS/GES) were studied relative to crash configuration and rider, motorcycle, and environment characteristics. Data trends before and after 1998 were examined. Key findings show that, in addition to the increase in crash risk due to exposure, motorcycle crashes are becoming more deadly. Contributing factors to increased severity and higher fatalities rates were: increased road departures and decreased helmet use for riders, especially those under 19 or 40-49 years of age, increased alcohol involvement for riders ages 30-49; vehicles turning into the path of the motorcycle, and head on crashes; lack of awareness of the impending crash; vulnerability of over 750cc engine size motorcycles in frontal crashes; riding on roads with higher speed limits; crashes away from a junction, and riders over 40 in dark road conditions. Overall, as compared to all crashes, a rider was about two times more likely to be killed in a road departure. Also, riders under age 30 were most vulnerable followed by riders over 50 in all motorcycle crashes. Findings support opportunities in safety strategies such as rider education, grouped by age, relative to speeding, helmet use, and alcohol consumption. Findings also support opportunities in countermeasures such as improved visibility including enhanced lighting, for the motorcycle and/or roadway, and improved performance of larger motorcycles in frontal crashes. Findings highlight the need to study the vulnerability of riders over 50 in motorcycle crashes and the need for a more in-depth study of the growing road departure motorcycle crash problem.

## INTRODUCTION

The number of motorcycle riders killed in traffic crashes on United States (U. S.) roads has increased for eight years in a row and has more than doubled since 1997 [1]. This increase recently overshadowed the decrease in passenger car crash fatalities and has led to an overall increase of

traffic fatalities in the U. S. In 2005, 4553 motorcycle riders died in U. S. crashes, accounting for 10.5% of all traffic fatalities. Given the recent growth of the motorcycle crash problem on U. S. roads, there is a critical need to gain an understanding of the factors contributing to motorcycle crashes. In this paper, results from a nationally representative descriptive analysis of U. S. motorcycle crashes are presented, including assessment of problem size and examination of recent trends. The goal of the research was to gain insight into crash causation and investigate opportunities for improving rider safety.

## STUDY POPULATION AND METHODS

**Database Selection** - In the U. S., there are two national traffic crash databases: the Fatality Analysis Reporting System (FARS) starting in 1975, and the National Automotive Sampling System (NASS) starting in 1988. FARS is a census of all fatal crashes and, as such, includes motorcycle fatalities. NASS is a stratified sample of police reported crashes of all severities and is composed of two systems: the General Estimate System (GES) and the Crashworthiness Data System (CDS). National estimates are calculated from NASS data by applying a national weight for each case. This national weight is the product of inverse probabilities of selection in a three stage sampling process.

Although CDS includes detailed vehicle, crash scene, and occupant data that allow study of injury mechanisms, the 5,000 tow-away crashes that are investigated per year do not include motorcycles. NASS/GES used for this study samples around 55,000 cases per year with major property damage, injury, or death from the several million police-reported crashes. GES data taken from police reports include motorcycle crashes and incorporates pre-event, rider, vehicle, environment, and limited injury data. NASS/GES was the most suitable database for this study. FARS was the source of the overall number of crash fatalities.

**Crash Population** - Weighted NASS/GES data from 1992-2004 of crashes with at least one motorcycle were used for this study. Motorcycles of all engine displacements were included. ATVs (all terrain vehicles) were excluded. The study population involved a national

estimate of 1,003,665 riders (motorcycle operators and passengers) summarized in Table 1.

**Table 1. 1992-2004 NASS/GES Motorcycle Population**

Crash Types	Sample Size	National Estimates
Single-Vehicle: one motorcycle	<b>9,993</b> (291)	<b>437,261</b> (9,993)
Two-vehicle	<b>9,904</b> (258)	<b>536,857</b> (9,904)
Multiple Vehicle	<b>631</b> (35)	<b>29,547</b> (631)

Fatalities in ( )

Motorcycles made up 2.54% of total vehicle registrations in 2005, with a low of 1.86% in 1998 and a high of 3.9% in 1981 [1]. Furthermore, motorcycle traffic exposure is expected to be far lower than registrations. In the landmark study by Hurt et al of on-scene and in-depth investigations of motorcycle crashes in Los Angeles during 1976 and 1977, motorcycles were reported to be 4% of registrations but were only 0.5% of vehicles observed in traffic [2]. In effect, seven out of eight motorcycles were parked at home in the garage. This leads to motorcycle crashes being a small segment of the police reported crashes sampled by GES. The sparse sample size is accentuated when looking at fatal crashes, which occur less frequently. Fatal motorcycle crashes are believed to be under-represented in GES. In the case of motorcycles, GES is more suited to look at trends and problem characterizations using data collected over several years.

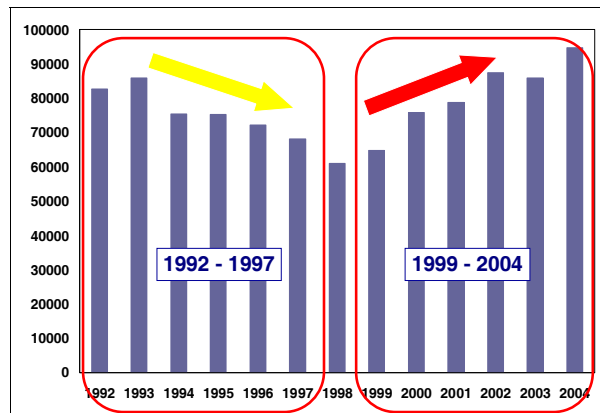
In this paper, crash configuration, rider, motorcycle, and environment characteristics were investigated by grouping thirteen years of weighted GES data from 1992 to 2004. The variables investigated variables are listed in Table 2. Although the visual obstruction and speed relation variables for the motorcycle rider were examined, results were deemed to be less reliable.

**Table 2. GES Variables Investigated**

<b>Crash Configuration:</b> - Accident Type	<b>Rider Related:</b> - Injury Severity - Age
<b>Environment Related:</b> - Speed Limit - Relation to Junction - Light Condition - Visual Obstruction - Road Surface Condition	- Safety Equipment Use - Restraint System Use (helmet) - Police Reported Alcohol Involvement - Driver Maneuvered to Avoid - Vehicle Maneuver
<b>Motorcycle Related:</b> - Make - Make (engine size) - Vehicle Contribution Factor	- Corrective Action Attempted

Motorcycle crashes had a downward trend in 1992-1997 followed by an upward trend in 1999-2004 as shown in Figure 1. A trend analysis grouping the two ranges of years was also performed. Crash characteristics were compared between the two ranges of years to study both involvement and severity for motorcycle crashes as shown in the sections below. Injury rates per 100 crash-involved occupants were examined and are presented beginning in Table 5.

**Crash Configuration Groupings** - The standard GES crash configuration groups were reassigned (Table 3) to better define the role of the motorcycle in the crash. The new assignments specify the crash configuration relative to the motorcycle. For example, in the case of rear-end with a passenger vehicle, the new groups identify if the motorcycle impacted the rear of the passenger car or vice-versa.



**Figure 1. Recent Trends of Motorcycle Crashes (GES)**

**Table 3.**

GES Category	Study Crash Configuration: GES ACCIDENT TYPE Codes
Single-Vehicle Crash	<b>Road Departure:</b> 01-10 <b>Frontal Impact:</b> 11-16
Pair and Multiple Vehicle Crashes	<b>Frontal Impact:</b> 20, 24, 28, 34, 36, 38, 40, 50-63, 69, 71, 73, 80, 81, 83, 86, 88 <b>Sideswipes:</b> 44-49, 64-67, 76-79 <b>Side Impact:</b> 68, 70, 72, 82, 87, 89 <b>Rollover:</b> 97 <b>Rear:</b> 21, 22, 23, 25, 26, 27, 29, 30, 31, 35, 37, 39, 41 <b>Other:</b> 92,93,98,99,00

**Note:** GES ACCIDENT TYPE codes [3]

Some GES cases were eliminated because the specifics were unknown and the role of the motorcycle could not be

determined. Most of these were multiple vehicle crashes. This resulted in 18,358 cases lost from 1,003,665 or less than 2% of the study population.

**Injury Severity Groupings** - The GES injury severity codes were grouped as non-severe injury, severe injury, and fatal injuries (Table 4).

Table 4. Study Injury Groups

	GES codes
Fatal Injury= K	K : Fatal Injury
Severe Injury = A	A : Incapacitating Injury
Non-Severe Injury = B+C+U	B : Non-incapacitating Injury C : Possible Injury U : Injured, Severity Unknown

**OVERALL MOTORCYCLE CRASH TREND AND RISK ASSESSMENT**

Motorcycle crashes and resulting rider fatalities have followed a similar trend in the last decade (Figure 2). In fact, since the mid 1980s, both the number of motorcycles on U. S. roads (registrations) and rider fatalities were decreasing until the reversal of trend in the late 1990s (Figure 3). The increase in motorcycle registrations, driven by the rapid increase in sales shown in Figure 3 [4], is a main factor contributing to the increase in motorcycle crashes on U. S. roads.

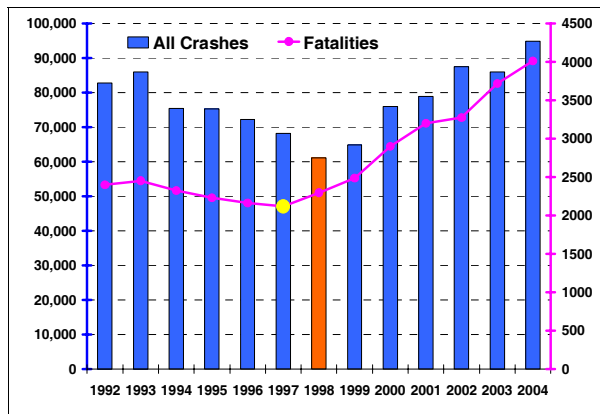


Figure 2. Motorcycle Crashes and Fatalities Trend. Crashes (weighted GES 1992-2004), Fatalities (FARS).

If we account for the increase in the size of the motorcycle fleet by normalizing with the number of registrations from the Federal Highway Administration (FHWA) [5], we find that motorcycle fatality rates per 100,000 registered

motorcycles increased from a low of 55 in 1997 to 73 in 2005 (Figure 4).

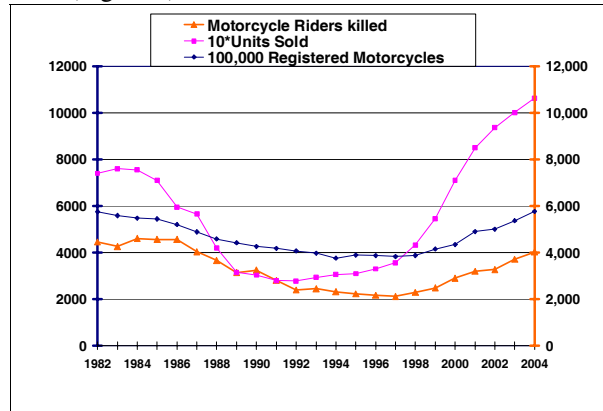


Figure 3. Motorcycle Fatalities (FARS), New Unit Sales (Motor Cycle Industry Council), Registrations (FHWA)

Motorcycle fatality rates have been rising since 1997 while, in comparison, passenger cars fatality rates have been steadily decreasing. Motorcycle riders represent a very vulnerable segment of road users in the U.S. In 2005, riders were 5.4 times more likely to be killed in motor vehicle traffic crashes per registered vehicle than occupants of passenger cars (who had a fatality rate of 13.6 per 100,000 registrations).

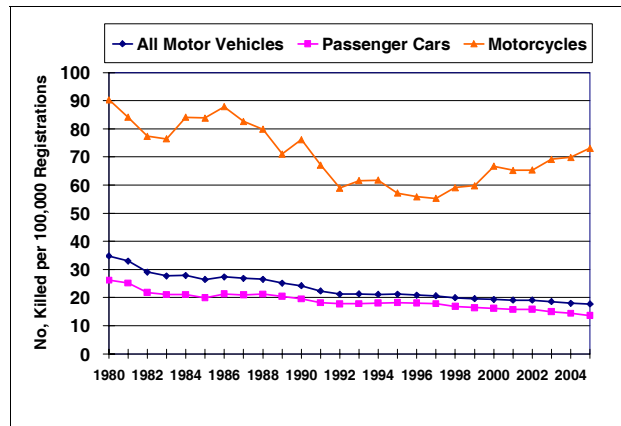


Figure 4. Fatality Rates per 100,000 Registered Vehicles (FARS, FHWA)

**Risk Assessment** - Are motorcycle crashes just becoming more prevalent and thus resulting in higher fatality rates per registered vehicle or are motorcycle crashes also becoming more dangerous? To obtain some insight into this question, the number of motorcycle crashes with different severity outcome (fatal, severe injury, non-severe injury, and no injury) per 100,000 registered vehicles was used as a relative measure of risk. Fatal risk was the ratio of fatalities from FARS and the injury risks were based on data from GES. The ratio for the total number of crashes was defined as involvement risk. It is worth noting that



miles traveled per registration would be the preferred metric for exposure. However, at this time, there is not much confidence in the miles travel data for motorcycle in the U. S. [6].

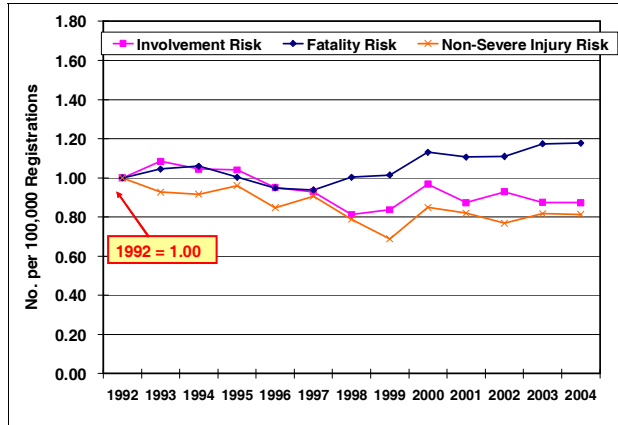


Figure 5. Motorcycle Crashes and Fatalities Risk Trend

In 2004, the risk for crash involvement decreased to 87% and non-severe injury risk decreased to 81% of 1992 levels, while the fatality risk was 18% higher in 2004 than in 1992 (Figure 5). This indicates that, although that there seems to be fewer crashes per registered motorcycle, the crashes tend to be more deadly in recent years.

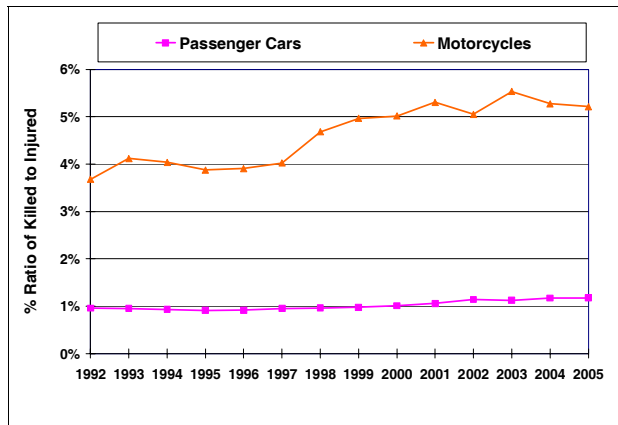


Figure 6. Ratio of People Killed (FARS) to the Number Injured in U. S. Crashes (GES) Trend

As another measure of risk, the ratio of people killed to the number injured people in traffic crashes over the last fourteen years was considered. For motorcycles, this ratio increased from 3.7% in 1992 to 5.2% in 2005 (Figure 6). In contrast, the ratio for passenger cars has more or less stayed in the same range with a relatively small increase (1% to 1.2%). This provides further evidence that, in

addition to becoming more prevalent, motorcycle crashes are becoming more severe.

**MOTORCYCLE CRASH CHARACTERISTICS**

**Crash Configuration** - Single-vehicle crashes, where only the motorcycle was involved, made up 44.2 % of the 1992-2004 GES population. Crashes with one other vehicle were 52.8% and crashes with multiple vehicles were 3.0%. The percent of single-vehicle crashes has been increasing in recent years to 47.5% in 2004 (Figure 7).

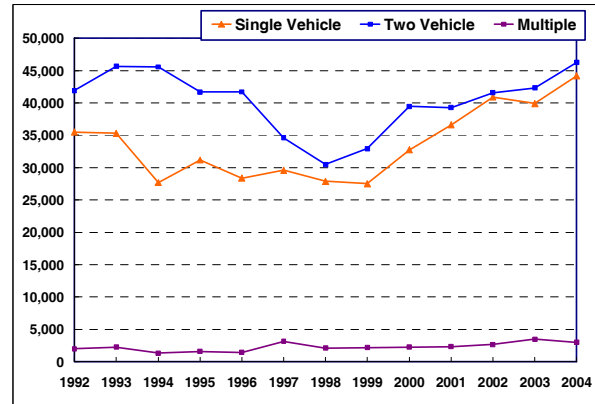


Figure 7. Motorcycle Crash Types (GES)

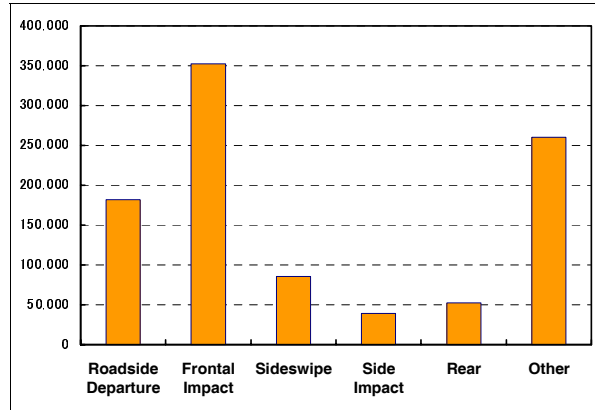
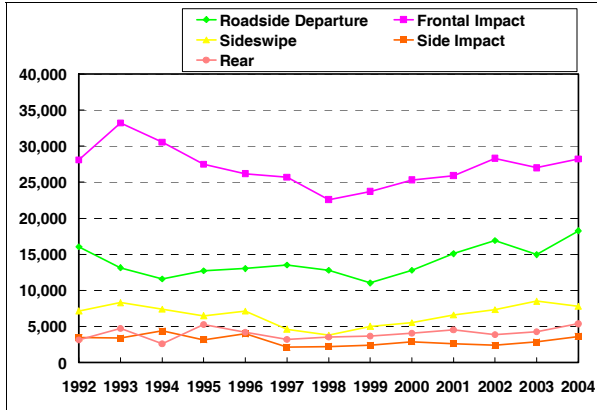


Figure 8. Motorcycle Crash Configurations (GES 1992-2004)

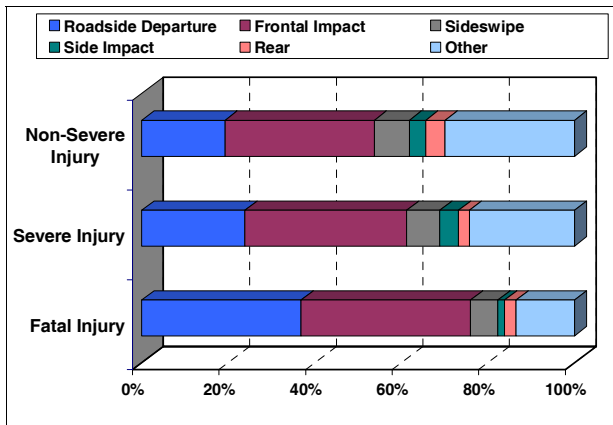
Frontal impact and road departure are the most common U.S. motorcycle crash configurations; both have been increasing in recent years (Figures 8 and 9). They are also the two most common configurations for all injury severities, especially fatal crashes, accounting for 75% of motorcycle riders killed from 1992-2004 (Figure 10).

However, road departures were especially lethal, accounting for 18.7% of all motorcycle crashes but 36.8% of the fatalities in the 1992-2004 GES data (Figures 9 and 10).



**Figure 9. Motorcycles Crash Configurations Trend (GES)**

As compared to all motorcycle crashes, a rider was about twice as likely to be killed in a road departure (ratio of 1.97 times). This corresponds to 1675 riders killed in road departures crashes from a total of 4553 fatalities in 2005 based on FARS. Frontal crashes were 36.3% of the GES crashes and resulted in 39.2% of the fatalities (1784 in 2005 based on FARS).



**Figure 10. Injury Severity by Motorcycle Crash Configuration (GES 1992-2004)**

**Table 5. Injury Rates per 100 Involved Riders in Frontal Crashes**

	1992-1997 GES	1999-2004 GES
Fatal	2.5	4.3
Severe Injury	26.2	27.7
Non-Severe Injury	53.2	48.9
No Injury	18.1	19.2

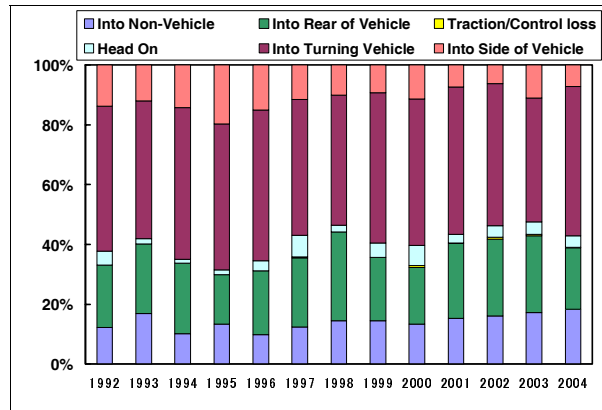
When comparing injury rates per crash before 1998 and after, GES data shows that both frontal and road departure crashes have become more severe in recent years (Tables 5 and 6). Deaths and severe injuries were a bigger percentage of the total crash population after 1998, while the percentage of non-severe injuries declined. Road departures had a higher fatality rate of 6.5 as compared to 4.3 for frontal crashes after 1998.

**Table 6.**

**Injury Rates per 100 Involved Riders in Road Departures**

	1992-1997 GES	1999-2004 GES
Fatal	4.5	6.5
Severe Injury	28.4	30.4
Non-Severe Injury	57.9	54.5
No Injury	9.1	8.6

**Motorcycle Frontal Crashes** - For a more in-depth examination, the frontal crash grouping was subdivided into six configurations outlined in Figure 11.

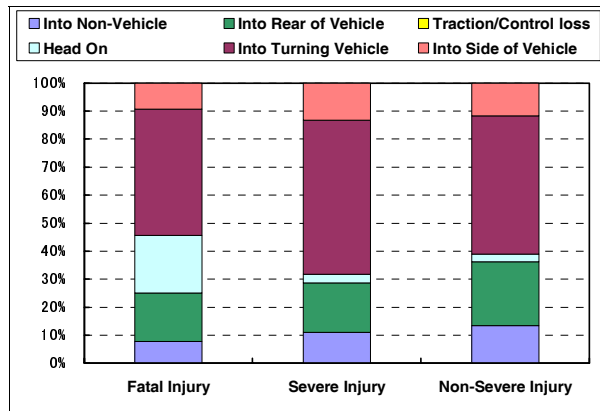


**Figure 11. Motorcycle Frontal Crash Configurations**

“Into Turning-Vehicle” configuration basically involves another vehicle turning into or across the path of a motorcycle moving straight forward. It is the most prevalent frontal crash configuration from 1992 through 2004, making up at 48.4% of the frontal crashes (Table 7) and 17% of all motorcycle crashes in the GES sample. “Into Rear of Vehicle” and “Into Non-Vehicle” follow at 23.4% and 13.5% of all frontal crashes respectively in 1992-2004.

**Table 7. Motorcycle Frontal Crashes GES (1992-2004)**

	% Frontal	% all GES	% Frontal Fatal	% all GES Fatal	Fatality Rate
Into Non-Vehicle	13.5%	4.7%	7.8%	3.0%	1.7
Into Rear of Vehicle	23.4%	8.2%	17.3%	6.7%	2.2
Head On	3.1%	1.1%	20.5%	8.0%	19.2
Into Turning Vehicle	48.4%	17.0%	45.0%	17.6%	2.7
Into Side of Vehicle	12%	4.1%	9.4%	3.7%	2.4

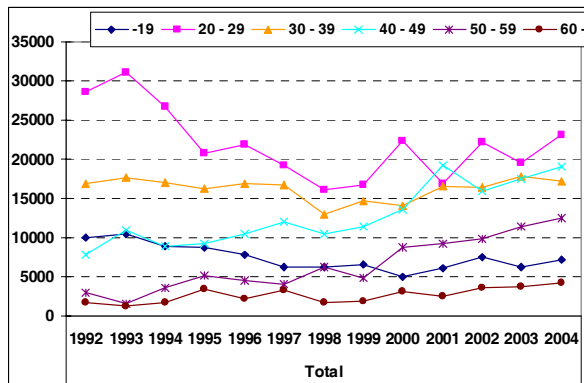


**Figure 12. Motorcycle Frontal Crashes by Injury Severity (GES 1992-2004)**

Head on crashes were only 3% of all the frontal crashes, but were vastly over-represented in fatalities, accounting for 20.5% of the riders killed. Crashes, where another vehicle turned into or across the path of a motorcycle, resulted in 45% of the fatalities for frontal collisions (Figure 12). Crashes where the motorcycle rear-ended another vehicle accounted for another 17.3% and crashes where the motorcycle crashed into the side of another vehicle resulted in 9.4% of the riders killed in frontal motorcycle crashes.

“Head On” motorcycle crashes have an exceptionally high fatality rate: 22% of head on collisions result in the rider being killed.

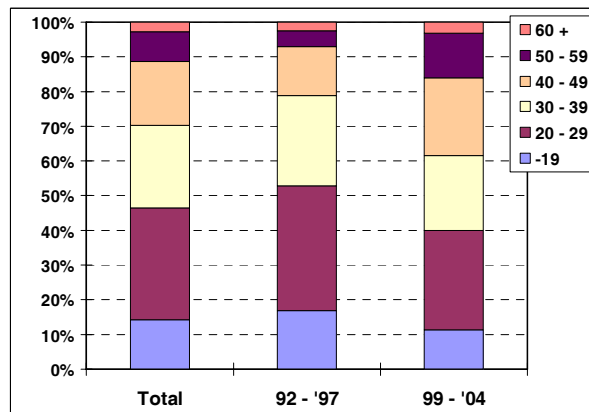
**Rider Age** - In 2004, riders in their twenties were still the largest segment (28%) of crash involved motorcycles riders; however, riders in their forties and fifties increased rapidly while the proportion of teenagers declined (Figure 13). In 2004, riders aged 40-49 were 23% of the GES crash population. Riders under 30 years old were 36% and riders over 40 were 43% of crash involved riders.



**Figure 13. Rider Age in Motorcycle Crashes (GES)**

Comparing involvement and fatality rates per crash involvement in the two ranges of years (1992-1997) and (1999-2004), riders under 30 years old were 42% of crash population and 51% of fatalities before 1998 but decreased to 36% of the accident population and 38% of fatalities after 1998. On the other hand, riders over age 40 increased from 24% of the crash population and 23% of the fatalities before 1998 to 38% of crashes and 40% of the fatalities after.

**Rider Age in Frontal Crashes:** Similar to the overall trend, the proportion of riders aged 40-49 and 50-59 involved and killed has increased in frontal crashes in recent years (Table 8 and Figures 14 and 15). However, while the number of crash involved riders in their twenties has decreased, they were a larger proportion of frontal crash fatalities in later years. Considering the ratio of fatalities to crash involvement, under 30 riders were 1.9 times more likely to be killed in a frontal crash in 1999-2004 than in 1992-1997. Over-50 riders were 1.7 times more likely to be killed in later years.



**Figure 14. Trend of Frontal Crashes by Rider Age (GES)**

**Table 8. GES Frontal Crashes by Rider Age**

Rider Age	1992-1997		1999-2004		Fatality Rate	
	All	Fatal	All	Fatal	92-97	99-04
-19	17%	12%	11%	6%	1.9	1.8
20 - 29	36%	28%	29%	37%	2.1	4.6
30 - 39	26%	40%	22%	19%	4.1	3.2
40 - 49	14%	13%	22%	20%	2.3	3.2
50 - 59	4%	2%	13%	13%	1.3	3.5
Over 40	21%	19%	38%	38%	2.3	3.6

**Rider Age in Road Departures:** There were similar trends for over-40 riders in road departures (Table 9). Riders under 30 were also twice more likely to be killed in a road departure in 1999-2004 than in 1992-1997. Riders

aged 40-60 were 1.5 times more likely to be killed in road departures in the later years.

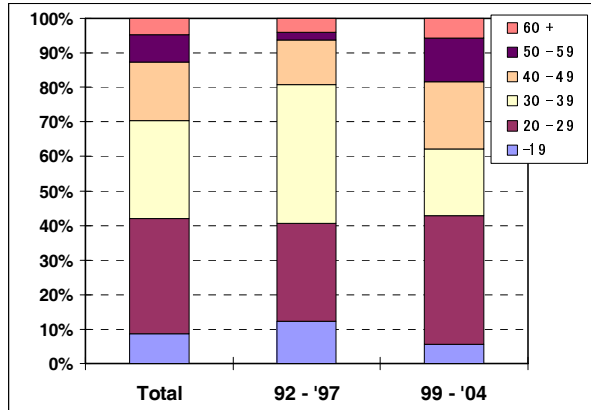


Figure 15. Trend in Fatal Frontal Crashes by Rider Age (GES)

Table 9. GES Road Departures by Rider Age

Rider Age	1992-1997		1999-2004		Fatality Rate	
	All	Fatal	All	Fatal	92-97	99-04
-19	13%	4%	8%	5%	1.5	4.0
20 - 29	38%	36%	29%	36%	4.3	8.0
30 - 39	25%	32%	23%	23%	5.9	6.4
40 - 49	14%	11%	20%	17%	3.3	5.5
50 - 59	6%	9%	14%	18%	6.8	8.4
Over 40	24%	27%	39%	35%	5.2	5.9

**Rider Action** - In 55% of recent motorcycle crashes, the rider was going straight prior to impact or prior to realizing an impending harmful event; however, in around 15% of the crashes the rider was negotiating a curve (Figure 16).

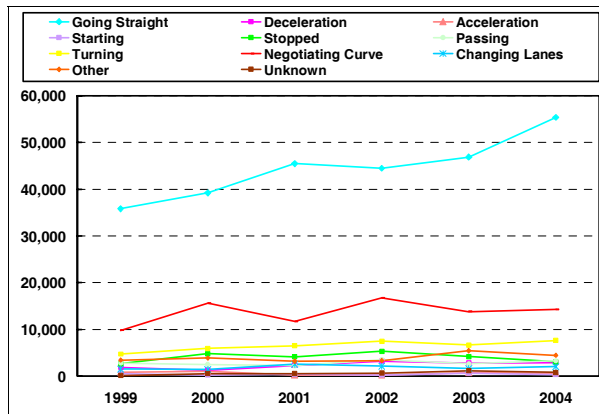


Figure 16. Motorcycle Rider Pre-Crash Action (GES)

As reported by GES, eighty percent of riders took no pre-crash evasive action in 1992-1997 (Figure 17) but this decreased to 73% in recent years. The driver attempted to brake and/or steer in 20% of the crashes after 1998.

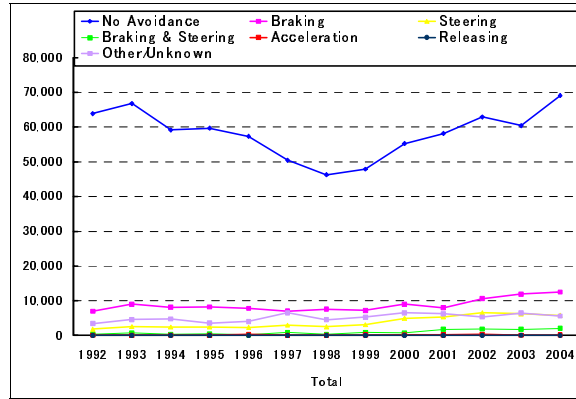


Figure 17. Crash Avoidance Action Taken by the Motorcycle Rider (GES)

In the GES data, in most crashes and at all severity levels, the rider was not able to or did not attempt any avoidance maneuver (Figure 18). In fatal crashes, 71% of all riders killed did not maneuver. The 50-59 age riders did not attempt to maneuver in 77% of fatal crashes. Given the challenges to establishing avoidance maneuvers from reports prepared by police officers who often lack any training or expertise in motorcycle accident investigation, these estimates are suspected to be high.

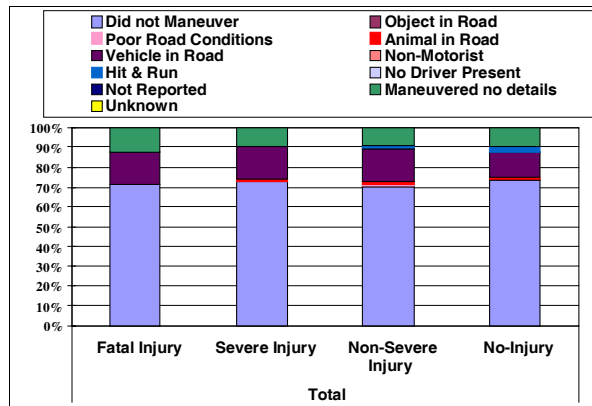


Figure 18. Situation that the Rider Maneuvered to Avoid (GES 1992-2004)

**Alcohol Involvement** - Most riders who were involved in crashes did not drink (Figure 19). However, alcohol use in fatal crashes increased from 18% in 1992-1997 to 22% in 1999-2004. This is a conservative estimate of alcohol use in fatal crashes because, as shown in Figure 20, alcohol use so often goes unreported by the police, particularly

when the rider survives more than a few hours after the crash.

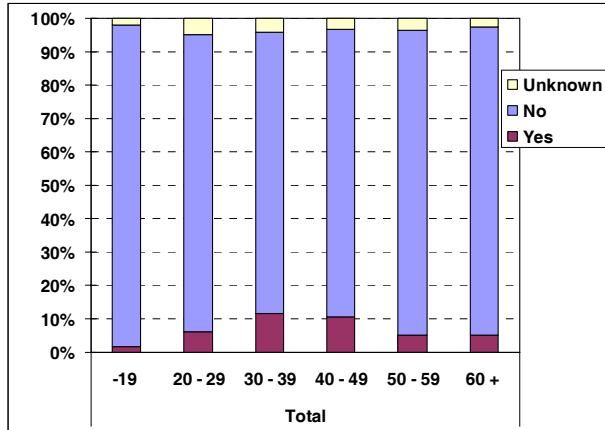


Figure 19. Alcohol Involvement by Age Group in Motorcycle Crashes (GES 1999-2004)

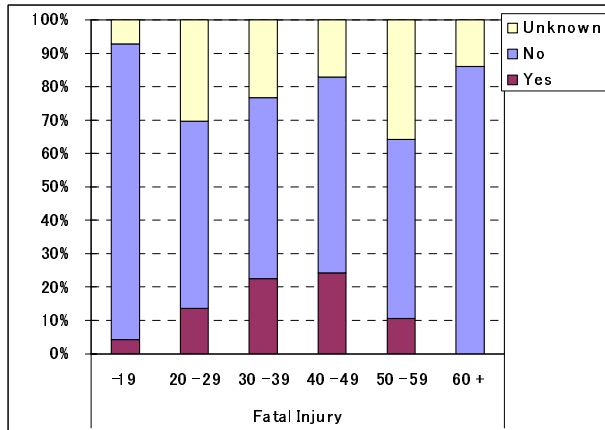


Figure 20. Alcohol Involvement by Age Group for Fatal Motorcycle Crashes (GES 1999-2004)

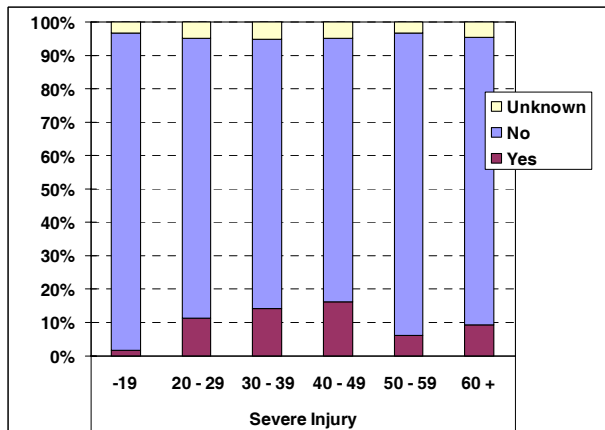


Figure 21. Alcohol Involvement by Age Group for Severe Injury Motorcycle Crashes (GES 1999-2004)

Looking at GES data with known alcohol involvement, there is marked increase in 30-49 year old riders who were drinking in motorcycle crashes at all severity levels relative to other riders (fatalities and Severe Injuries shown in Figures 20 and 21).

**Helmet Use** - Reported helmet use increased from 52% in 1992-1997 to 57% in the years since 1998 (Figure 22). However, some caution is required in interpreting this data, because of the growing use in the last 15 years of ineffective and unqualified “novelty” head gear that provide no protection in a crash [7]. If users of “novelty” head gear are classified as “helmeted” it can make head protection usage appear higher than it really is.

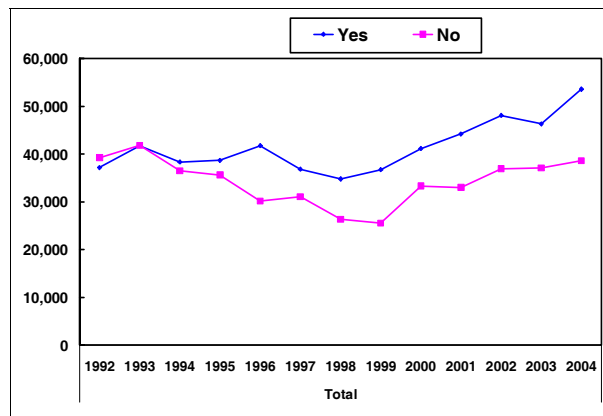


Figure 22. Helmet Use in GES Motorcycle Crashes

Taking a look at fatalities by age group, there is marked decrease of helmet use for the 40-49 and under-20 age groups since 1998, and to a lesser degree in the 20-29 age group (Figure 23). After 1998, fatally injured riders aged 40-49 were 75% as likely to have a helmet on compared to 1992-1997 (45% vs. 61%). Helmet use declined by 22% among fatally injured teenage riders after 1998 (from 54% to 42%).

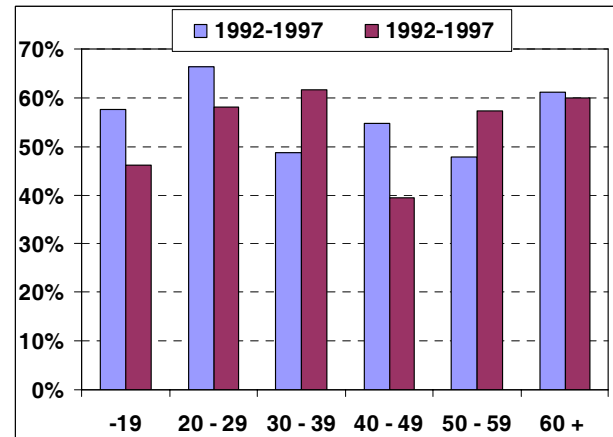


Figure 23. Helmeted Riders by Age Group in Fatal GES Crashes

**Speed Relation** - A large percentage of fatal GES motorcycle crashes were coded as speed related when compared with crashes with less severe outcomes: 39.5% of fatal crashes, 27.1% of severe crashes versus 13.7% of no injury crashes were coded by police in 1992-2004 with speed being a contributing cause of the crash. Also, a larger proportion of fatal crashes were coded as speed related for the younger riders. Actually, 54% of fatal crashes for rider under 30 are coded as speed related in contrast with 26% of fatal crashes for riders over 40 years old. As a caveat, speeding as reported by the police is approximate and not determined by rigorous speed analysis methods. Given the cursory nature of reporting speeding, it is the judgment of the authors that the type of motorcycle involved (sport bike vs. cruiser) or the severity of rider injuries may play a major role in the investigating officer's conclusion that speed was a factor in the crash. As such, the speed relation data reported in GES is not considered to be very reliable.

**Motorcycle Engine Displacement** - The motorcycle engine displacement in cc (cubic centimeters), an indication of size, was extracted from the vehicle model variable in GES. The engine size was identified for around two-thirds of the GES motorcycle crash population from 1999-2004 but only for one-fourth of the population in 1992-1997. As such, only GES crashes after 1998 were further examined by engine size.

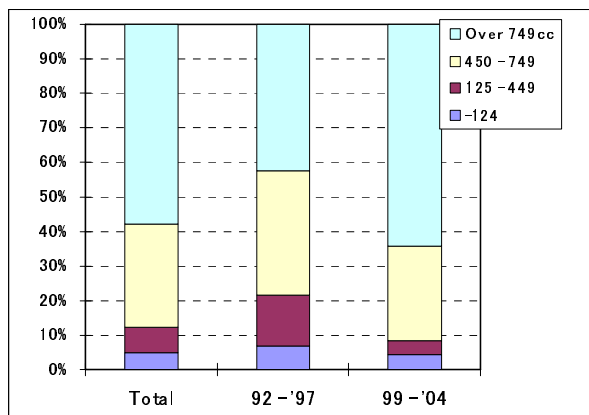


Figure 24. Frontal Crashes by Engine Size in cc

The data indicate a relative increase in bigger bikes in both frontal and road departure crashes in recent years. (Frontal crashes are shown in Figure 24). Motorcycles with engine displacement over 750cc were dominant in both frontal impacts and road departures at all severity levels (Table 10). Larger motorcycles had a higher fatality rate per crash involvement than the 450-749cc in frontal crashes: over 750cc riders were 1.5 times more likely to be killed in frontal crashes than those on 450-749cc bikes. On the

other hand, both motorcycle sizes had a similar but high fatality rate in road departure crashes (riders of over 750cc size where 1.1 times more likely to be killed as those on smaller motorcycles).

Table 10. Fatal Crashes by Engine Displacement GES (1999-2004)

Severity	Engine size (cc)	Rate per 100 Crash involved		% Total	
		Frontal	Road Depart	Frontal	Road Depart
Killed	450-749	3.5	6.4	22%	25%
	≥ 750	5.2	6.8	77%	68%
Severe injury	450-749	24	32	24%	30%
	≥ 750	29	31	67%	66%
Non-Severe injury	450-749	51	57	28%	31%
	≥ 750	48	53	64%	63%
All crashes	450-749	-	-	27%	29%
	≥ 750	-	-	64%	64%

**Motorcycle Contributing Factor** - Motorcycle components, listed in Figure 29, did not have any failures and were not a contributing factor in almost all the crashes (Figure 25).

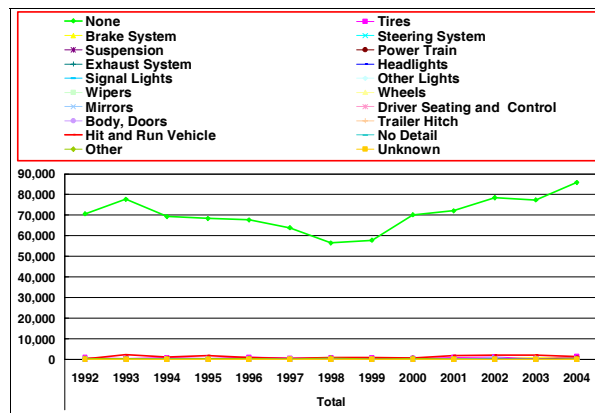
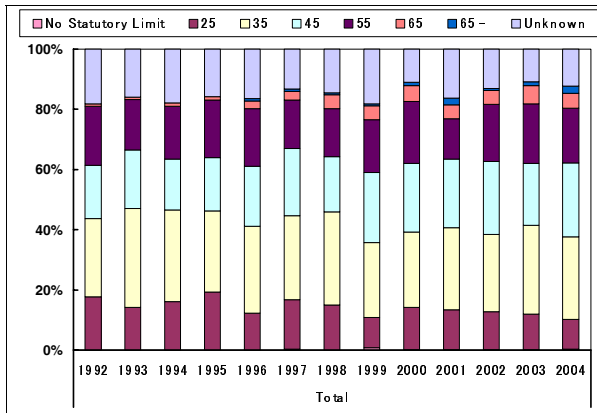


Figure 25. Motorcycle Contributing Factor in GES Crashes

### Crash Environment Variables

**Speed Limit** - Motorcycle crashes from 1992-2004 occurred on roads with all speed limits. However, there is recent increase in number of crashes occurring on roads with speed limits of 65 mph and over (Figure 26).



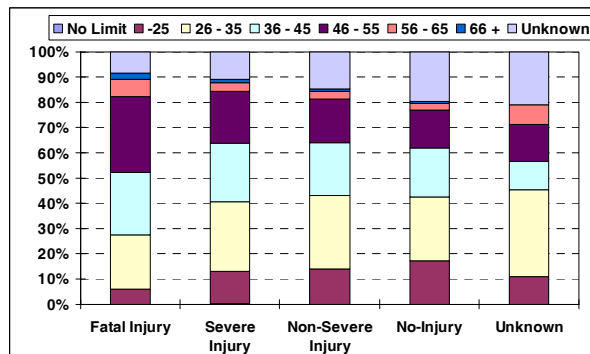
**Figure 26. Motorcycle Crashes by Posted Speed Limit in Miles per Hour (mph) (GES)**

As expected, there is an increase in crash severity levels on roads with higher speed limits as shown in Table 11. Fatality rates increased from 1.2% on roads with a speed limit less than 25 mph speed limit to 8.1% for roads with a limit over 65 mph.

**Table 11. Crashes per Posted Road Speed Limit (mph)**

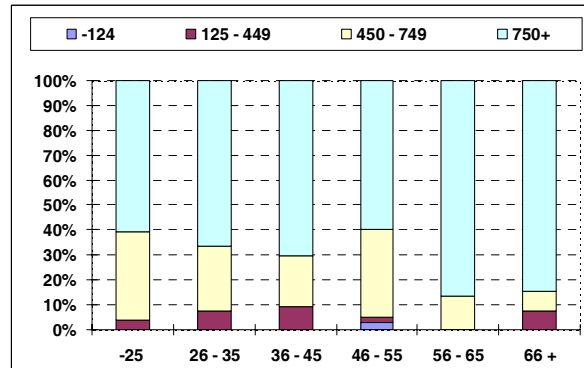
	- 25	26-35	36-45	46-55	56-65	65 +
% crashes	14%	28%	21%	18%	3%	1%
% fatalities	7%	24%	27%	33%	8%	3%
Fatality Rate	1	2	3	5	6	8
Severe Injury Rate	22	23	26	27	26	33
450-749cc fatality rate	1	2	4	6	5	4
750+ cc fatality rate	2	3	5	5	8	9

Motorcycle crashes on roads with 46-55 mph speed limits were 18% of motorcycle crashes but resulted in 33% of the fatalities on roads with known speed limits. Crashes on roads with 45 mph and 35 mph resulted in 27% and 24% of riders killed, respectively (Table 11 and Figure 27).



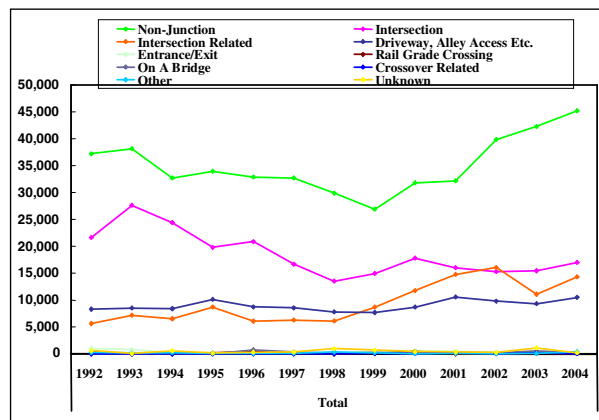
**Figure 27. Injury Severity by Speed Limit for GES Motorcycle Crashes (1992-2004)**

Motorcycles with engine displacement over 750cc are dominant at all severity levels with percentages increasing at higher speeds limits. However, the 450-749cc size is over-represented on 55 mph speed limit roads, making up 31% of the crashes and 35% of the fatalities (Figure 28).



**Figure 28. Fatal Crashes by Speed limit and Engine Displacement (GES 1999 - 2004)**

**Relation to Junction** – GES specifies the location of the first harmful event in relation to a road junction. The point of departure is indicated if the first harmful event occurs off the roadway.



**Figure 29. Motorcycle Crashes by Relation to Junction (GES)**

Overall, in 1992-2004, 48% of motorcycle crashes occurred away from a junction while 38% percent were within an intersection (Figure 29). However, a disproportionate share of fatalities – about 64% -- occurred in non-intersection crashes, while only 27% happened within an intersection (Figure 30). Crashes away from a junction had a fatality rate of 4.3 over 1992-2004, about 72% higher than crashes within an intersection, which had a 2.5 fatality rate. Crashes away from a junction have also increased steadily in recent years.

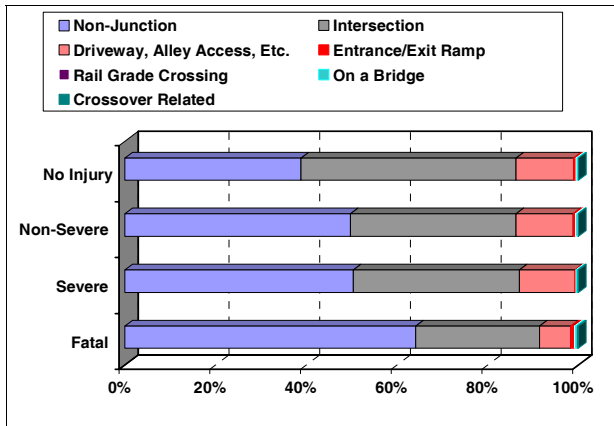


Figure 30. Injury Severity by Relationship to Junction for Motorcycle Crashes (GES 1992-2004)

**Road Surface Condition** - The great majority of motorcycle crashes in 1992-2004 happened on dry roads. As such, the increase in crashes on dry roads since 1998 simply followed the trend of all motorcycle crashes on U. S. roads (Figure 34).

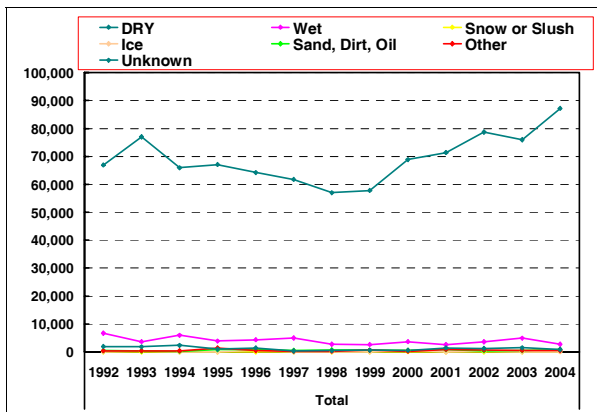


Figure 31. Road Surface Condition for Motorcycle Crashes (GES)

**Visual Obstruction** – GES identifies visual circumstances that may have contributed to the cause of the crash. In the majority of the motorcycle crashes from 1992-2004 no visual obstruction was reported. However in recent years this variable often was not reported. As such, it was impossible to determine any reliable trends relative to visual obstruction in this study.

**Light Condition** - GES also identifies the general light condition at the time of the crash, considering the presence of external roadway lighting fixtures.

The majority of motorcycle crashes, 69%, occurred in the daylight in 1992-2004 (Figure 32). The number of

motorcycle crashes occurring in the daylight increased in recent years, following the general trend.

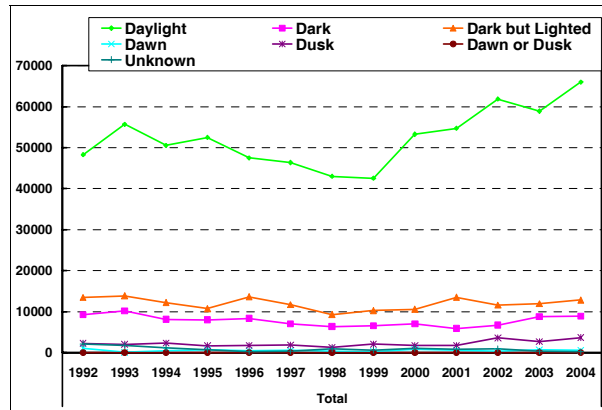


Figure 32. Light Condition for GES Motorcycle Crashes

Although 26% of the crashes occurred during hours of darkness (dark and dark but lighted), those crashes resulted in over 43% of the fatalities (Figure 33). Crashes in unlighted darkness were more likely to result in death than those occurring on lighted roadways at night (5.2 vs. 3.8 per hundred crashes). Also, crashes on unlighted roadways had a lower “no injury” rate than in the dark but lighted condition (9 vs. 15).

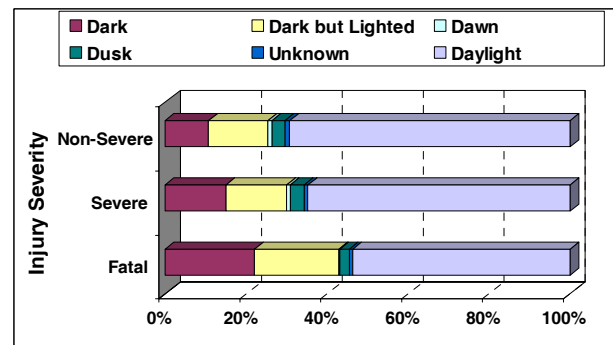


Figure 33. Injury Severity by Light Condition for GES Motorcycle Crashes (1992-2004)

Riders age 40 and older were over-represented in fatal motorcycle crashes that occurred on unlighted dark roads. They were 33% of all crash involved riders but 45% of riders killed on dark unlit roads (Figure 34). In contrast they were not over-represented on lighted roads at night, where they were 29% of crashes and 26% of fatalities (Figure 35). That is, riders over 40 were 1.5 times as likely to die if they crashed on a road that was unlighted at night compared to night crashes on roads that were lighted.



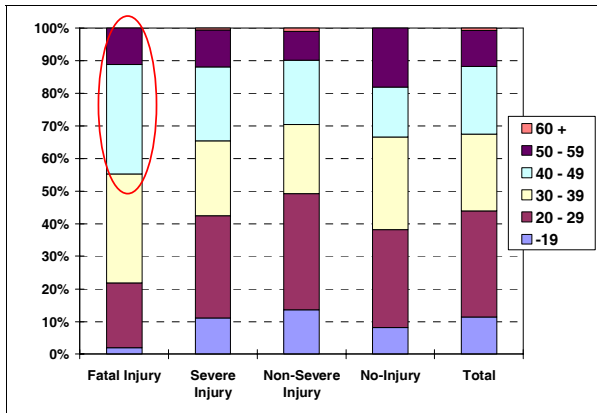


Figure 34. DARK-Unlighted by Injury Severity and Age (1999 - 2004)

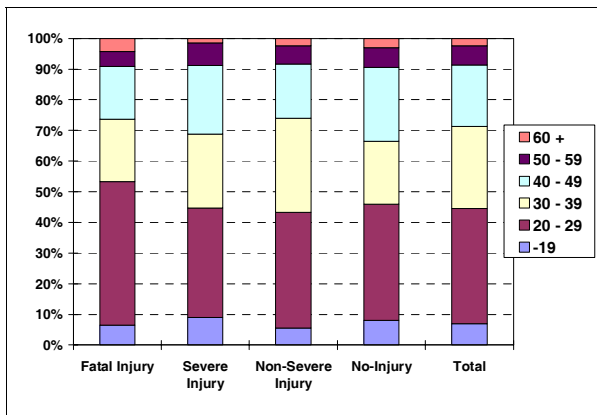


Figure 35. DARK but LIGHTED by Injury Severity and Age (1999 - 2004)

## SUMMARY AND CONCLUSIONS

Results from this nationally representative descriptive overview of motorcycle crashes in the U. S. roads are summarized below. Key observations derived in this study are compared with findings from a recent statistical study of motorcycle crashes in the state of Indiana from January 2003 to October 2005 [8] and the landmark study by Hurt et al of on-scene, in-depth investigation of motorcycle crashes in Los Angeles during 1976 and 1977 [2]. The Indiana study, by Savolainen and Mannering, used nested logit and standard multinomial logit probabilistic models to show which variables play significant roles in motorcycle crash injury outcomes in Indiana.

Motorcycle crashes have been on the rise in the U. S. due to increased exposure driven by the rapid increase in sales since the late 1990s. However, motorcycle crashes, when they occur, are becoming more deadly. Relative to 1992 levels, the risks for being in a crash or in a non-severe crash per registered motorcycle decreased by 13% and

19% respectively in 2004 while the risk of being in fatal motorcycle crash increased by 18%. This indicates that, although that there seems to be fewer crashes per registered motorcycle, the crashes tend to be more deadly in recent years. Motorcycle riders also represent a very vulnerable segment of road users in the U.S. Inherently, a motorcycle offers little protection to the rider in a crash. Riders were over five times as likely to be killed in a traffic crash in 2005 as occupants of other motor vehicles.

**Crash Configuration:** Frontal impacts and road departures were the two most prevalent motorcycle crash configurations. They were also dominant in all injury severities. Frontal impacts were 36% of all crashes and accounted for a proportionate 39% of fatalities. However, road departure crashes were far more lethal, accounting for 19% of all crashes but 38% of all fatalities. These two configurations alone accounted for 75% of motorcycle death in 1992-2004. In the Indiana study, road departure crashes and collisions with roadside objects were found to be much more likely to produce severe injuries, and collisions with trees and poles were the most likely to produce a fatality.

Both frontal and road departure crashes have become more severe in recent years. When comparing injury rates before and after 1998, the fatality rate for road departure increased from 4.3 to 6.5 per hundred crashes while the fatality rate for frontal crashes increased from 2.5 to 4.3 per hundred.

“Head On” motorcycle crashes have an exceptionally high fatality rate of 19.2 of riders killed per hundred head-on crashes – over 5 times the rate of frontal crashes generally. “Head On” frontal crashes accounted for 8% of all riders killed, but only 1.1% of all the motorcycle crashes in this study. Similarly, in the Indiana study, head on crashes greatly increased the probability of fatalities, resulting in a 566% higher likelihood of being killed.

Crashes where another vehicle turned into or across the path of a motorcycle moving straight ahead were the most common frontal crash configuration at 17% of all motorcycle crashes and accounted for 18% of all riders killed. Motorcycles running into rear of other vehicles were 8% of all crashes and 6.7% of rider fatalities.

The most common crash configurations reported by Hurt et al in the Los Angeles study involved another vehicle turning left across the path of a motorcycle coming from the opposite direction (22% of all crashes) and road departure (16%).

**Rider Age:** The motorcycling population is getting older. The proportion of crash-involved riders age 40 and older has increased considerably in recent years, from 24%

before 1998 to 38% after. The percentage of riders over 40 who were killed in motorcycle crashes nearly doubled after 1998 to 40% of all riders killed. In contrast, Hurt et al reported a median age of 26 for riders killed in their 1976-77 crash population, with riders 17-26 years old accounting for 50% of the fatalities.

The recent increase in age for the crash involved rider follows the trend in motorcycle owner age in the U. S. According to the Motorcycle Industry Council Surveys of Motorcycle Ownership and Usage, the median age of motorcycle owners was 41 years old in 2003 as compared to 27 years in 1985 (a 14 year increase in median age over an 18 year period) [4]. Motorcycle owners over 40 years old were 53% in 2003, steadily increasing from 21% in 1985, 26% in 1990, and 44% in 1998.

Similar to the trend in all motorcycle crashes, riders 40-59 years old have increased in both frontal impacts and road departures in recent years. However, while the numbers of riders 20-29 in motorcycle crashes have decreased in recent years, they were a bigger proportion of the fatalities. Considering the ratio of fatalities to crash involvement, riders under 30 were 1.9 times more likely to be killed in a frontal crash and twice as likely to die in a road departure after 1998 as compared to 1992-1997. The over-50 rider was 1.7 times more likely to be killed in recent frontal crashes and 1.5 times more likely to be killed in recent road departures. In the Indiana study, the results showed that older riders were more likely to be involved in both single- and two-vehicle severe crashes, even when controlling for all other factors.

**Rider Pre-Crash Evasive Action:** For most crashes at all severity levels, police reported that the motorcycle rider was not able to or did not attempt any avoidance maneuvers. The absence of evasive action was reported in 71% of fatal crashes, and for 77% of all riders aged 50-59. Given the challenges to establish avoidance maneuvers from police reports, these estimates are suspected to be high. Hurt et al reported nearly the opposite: Riders took evasive action nearly 70% of the time, but often made poor choices and executed their chosen action poorly. Part of the problem, according to Hurt, is that riders had little time to react before the crash (a median of 1.9 seconds, and less than 3 seconds to react in over 90% of crashes). Overall, both the GES and Hurt data indicate that motorcyclists and car drivers exhibit a lack of awareness or no expectation of impending danger in motorcycle involved crashes.

One of the principle findings from the Hurt study was that lack of “motorcycle conspicuity” and lack of caution and awareness of both rider and driver were main causes of two-vehicle motorcycle crashes. The driver of the other vehicle who violated the motorcycle right-of-way in 64% of the crashes explained that he/she never saw the

motorcycle before the crash. Lack of motorcycle conspicuity is highlighted as a factor contributing to increased motorcycle crash severity by several researchers [9, 10].

**Alcohol Involvement:** Comparing the years before and after 1998, the percent of riders who died in a motorcycle crash after drinking increased from 18% to 22%. This is a conservative estimate due to large proportion of unknown alcohol involvement in GES fatal crashes. Hurt reported alcohol use in 12% of all crashes and 43% of fatalities. NHTSA reported alcohol use in 34% 2005 fatal motorcycle crashes and a blood alcohol level (BAC) 0.08 g/dl or higher in 27% of motorcycle fatalities [11]. In this study, the GES data showed a marked increase in alcohol use among the 30-49 age groups at all severity levels relative to other riders. According to NHTSA, in 2005 the age group that had the highest percentage of riders with BAC of .08% or higher were those aged 35-50.

Relative to other parts of the world, the ratio of alcohol involvement in 2004 U. S. motorcycle crashes was 6.2 times higher than Japan and 1.8 times that of the European Union (EU). This is based on comparison of data from U. S. GES, EU MAIDS [12], and Japan ITARDA [13].

Studies have shown that alcohol has a pervasive and detrimental effect on motorcycle crash characteristics, including a big increase in road departure crashes (Hurt Study [14], Thailand study [15]) and decreased helmet use [14]. Alcohol crashes also mostly occur at night in non-junction areas (Thailand study [15], Hawaii study [16]).

**Helmet Use:** Forty-three percent of the 1999-2004 motorcycle crash population in the U. S. did not wear a helmet. Comparing the years before and after 1998, helmet use by riders killed in motorcycle crashes declined from 61% to 45% among riders aged 40-49 and from 54% to 42% among those younger than 20.

In the Indiana study, results showed 50% increase in no injury for helmeted riders in single vehicle crashes. Savolainen and Mannering also report that helmet use significantly increased the probability of “non-incapacitating” injuries in crashes with sport utilities vehicles and pickup trucks in Indiana.

NHTSA reported that use of a qualified helmet was 37% effective in preventing fatalities in motorcycle crashes in 2005 [11]. Similarly, Ouellet & Kasantikul [17] reported that about half of all fatally injured motorcyclists died of non-head injuries, usually to the chest and abdomen. Of those who died primarily from head injuries, helmet use would have prevented nearly 80% of those deaths.

Unfortunately, NHTSA reported that helmet use declined from 71% in 2000 to 48% in 2005 based on their National Occupant Protection Use Survey (NOPUS). States in the U. S. have been repealing laws that require helmet use for all riders. The number of States with mandatory helmet laws has declined from 27 in 1996 to 22 in 2005 [18]. Many studies comparing the effect of mandatory helmet has shown that mandating helmet use for all riders increases use to over 90% and reduces fatalities [19, 20, 21, and 22].

One caveat is necessary in discussing helmet use. Since the early 1990s, the use of “beanie” or “novelty” headgear with no energy-absorbing liner that are incapable of providing crash protection has grown in the U. S. [23] Roadside observational surveys in Florida by Turner at al show that use of “beanie” headgear increased from 15% in 1992 to 40% in 1999 [7]. It is unclear how often the distinction between qualified protective helmets and beanie headgear is made in the police reports that make up the GES data.

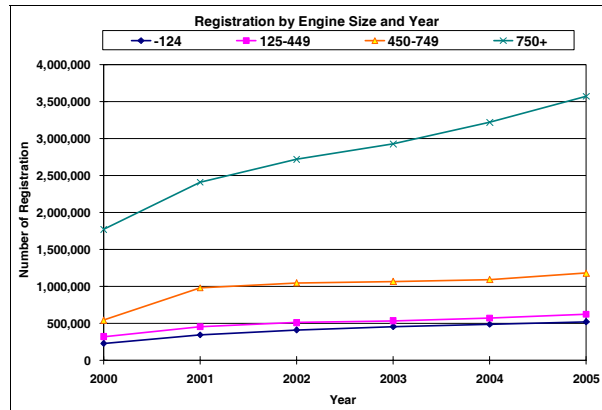
It is also worth noting that riding without a helmet is far more common in the U.S. than in Japan or the European Union. The percentage of American riders who crashed without a helmet was 36 times greater than Japan and five times greater than the EU [12, 13].

**Motorcycle Factor Related:** The motorcycle itself did not have any failures and was not a contributing factor in almost all the GES crashes. Motorcycles with engine displacement over 750cc dominated both frontal impacts and road departures at all severity levels in recent motorcycle crashes. They were involved in 77% of frontal crashes and 68% of road departures in 1998-2004.

Large-displacement motorcycles have been increasing in the U.S. The Motorcycle Industry Council estimates that motorcycles over 749cc increased from 66% of the total motorcycle population in 1998 to 76% in 2003 [4]. In the same years, the 450-749cc motorcycles decreased from 21% to 16.5%. Polk’s National Vehicle Population Profile (NVPP) data shows a continued increase in overall motorcycle registration in the U. S., particularly for over-750cc motorcycles (Figure 36) [24].

The over 750cc motorcycles have a higher fatality rate per crash involvement than the 450-749cc in frontal crashes (5.2 vs. 3.5%). Riders on 750+ cc motorcycles were 1.5 times more likely to be killed in frontal crashes than those on 450-749cc motorcycles. However, both motorcycle sizes had a similar but high fatality rate in road departures (6.4% for 450-749cc riders and 6.8% for riders of over 750cc riders). Hurt et al reported the over 750cc motorcycles were under-represented in the crash population compared to their exposure on the street while

their involvement in fatal crashes more closely reflected their exposure in street traffic.



**Figure 36. Polk NVPP Motorcycle Registration Data by Engine Displacement**

**Posted Speed Limit:** Motorcycle crashes occur on roads with all speed limits. As expected, there is an increase in crash severity levels on roads with higher speed limits. Thirty percent of the fatal crashes occurred on roads with 46-55 mph speed limits. The Indiana study reported a 32% higher likelihood of a fatality on roads with speed limits over 50 mph. However, 52% of the GES fatal crashes occurred on roads with speed limits less than 45 mph.

Motorcycles with engine displacement over 750cc dominated all severity levels with percentages increasing at higher speeds limits. However, the 450-749cc size was prominent on roads with 45-55 speed limits and was involved in 35% of the fatal crashes.

**Relation to Junction:** In 1992-2004, 38% of crashes occurred within an intersection and 48% away from a junction. However, crashes away from a junction were 1.7 times more likely to be fatal than crashes within an intersection. Non-junction crashes accounted for 64% of riders killed. In the Hurt study, intersection crashes were also less likely to be fatal than non-intersection: 65% of all crashes but only 33% of fatalities occurred in intersection crashes. Hurt et al reported that fatal crashes were more likely to involve the rider losing control by running off the road, typically on a curve. In the Indiana study, intersection crashes were found to be more likely to result in no injury for single vehicle crashes. The higher fatality rate for non-junction crashes may be related to alcohol use, since road departure crashes are far more common among drinking riders and are much more likely to be fatal.

**Road Surface and Light Conditions:** Motorcycle crashes in 1992-2004 occurred primarily on a dry road surface, with almost 70% occurring during daylight. Hurt

et al. reported that motorcycles virtually disappear from the roads when they are wet, an indication of low exposure for motorcycles in inclement weather conditions. Kasantikul [25] reported the same thing in Thailand, where rain is far more common than in Los Angeles and motorcycles tend to be the riders only mode of transportation.

While crashes at night were 30% of all crashes, they accounted for over 43% of the fatalities. Fatality rate per 100 crash involved riders is higher in crashes occurring on dark unlighted roads compared to those on dark but lighted roads (5.2 vs. 3.8). Riders over 40 years old were over-represented in fatal motorcycle crashes on dark, unlighted roads, making up 45% of those killed. In contrast, they were only 26% of riders killed on dark but lighted roads. Riders over 40 involved in a crash at night were 1.5 times more likely to die if they crashed on an unlighted road than on a lighted roadway.

In the Indiana study, crashes occurring in darkness were 95% more likely to result in a fatality in single-vehicle crashes and a twice as likely in multi-vehicle motorcycle crashes. The association of darkness and fatalities may be related to alcohol and crash type. Most alcohol-involved crashes occur at night [15, 16] and alcohol use greatly increases the likelihood of road departure crashes [15].

## **OPPORTUNITIES FOR SAFETY IMPROVEMENTS**

Key findings of this 1992-2004 NASS/GES motorcycle crash study are that the doubling of motorcycle fatalities is largely due to increasing numbers of motorcycles in use and that motorcycle crashes are becoming more deadly in recent years. Road departure crashes are disproportionately fatal and they have been increasing, possibly because of increasing alcohol use.

Examination of motorcycle crash data trends before and since 1998 show that increased severity and higher fatality rates in recent years can be mainly attributed to:

- Increase in road departures, vehicles turning into the path of the motorcycle, and head-on crashes
- Decrease in helmet use, particularly for riders under 19 and 40-49 years old
- Increase in alcohol use for riders aged 30-49
- Vulnerability of over 750cc engine size motorcycles in frontal crashes
- Riding on roads with higher speed limits
- Crashes away from a junction (possibly related to alcohol use and road departure crashes)
- Riders over 40 in dark road conditions (also possibly related to alcohol use at night and road departure).

Findings support opportunities in safety strategies such as rider education, focused by age groups, relative to speeding, helmet use, and alcohol consumption. Speed risk awareness campaigns can be focused to younger drivers. Alcohol involvement risk awareness education can be focused to rider ages 30-50. Any action that will work to increase the use of qualified helmets will reduce fatalities. As compared to other part of the world, there are considerable opportunities for improvements to lessen alcohol use and increase helmet use for the U. S. motorcycle rider.

Countermeasures to improve visibility would reduce fatalities, in particular for the rapidly growing population of riders over 40 years of age. This includes enhanced lighting, whether for the motorcycle and/or the roadway. Although motorcycles of all engine sizes are vulnerable in road departure crashes, the over 750cc riders were 1.5 times more likely to be killed in frontal crashes than riders of 450-749cc motorcycles. It is not clear what factor or factors might explain the increasing fatality rate on large displacement motorcycles. Crash speed, helmet use or even changes in rider crash motions are possibilities, but on-scene, in-depth crash investigations may be required to resolve this issue.

Findings also support the need to study the vulnerability of riders over 50 in motorcycle crashes, in particular, relative to pre-crash behavior and susceptibility to injury. Finally, findings highlight a critical need for an in-depth study of the growing road departure motorcycle crash problem.

## **FURTHER STUDIES**

Some limitations of this study are as follows. Overall, GES provides a historical perspective of a large number of useful crash, rider, motorcycle, and environment attributes. However, fatal and high severity crashes are believed to be under-represented. Also, GES does not provide sufficient detail to obtain a good understanding of crash causation, injury mechanisms, and crash dynamics.

An examination of injury severities in crashes where the rider attempted braking or steering corrective actions would be useful. A study of injury severity and other attributes in crashes where the rider was negotiating a curve is needed. Also, some rider attributes and crash characteristics are interrelated and their linkage requires further examination; e.g., alcohol involvement, inattention, road departure and pre-crash evasive actions. While this crash study focused on the motorcycle and rider, a study of the attributes of the other vehicle and driver would provide more insights into motorcycle crash involvement and severity in two-vehicle crashes. In particular, investigating the role of visual obstruction, pre-crash actions, vehicle

maneuvers, alcohol involvement, speed relation, and vehicle class would be useful.

Focused studies based on the more comprehensive U. S. state crash data files, such as the Indiana study, can provide better insights to crash attributes such as the influence of roadway features, environmental factors, rider pre-crash actions, and other vehicle characteristics. In-depth studies, such as special crash investigations and crash reconstructions would be very valuable to understand injury mechanisms and crash dynamics. Such studies would also better support the development of engineering countermeasures to the rapidly growing motorcycle crash problem.

#### ACKNOWLEDGEMENTS

This study was performed at the National Crash Analysis Center (NCAC) of George Washington University. The authors would like to acknowledge the contributions of Dr. Gerry Stewart of Stewart Statistical Services for his expert data analysis, and Dr. Kenneth S. Opiela of FHWA and Umesh Shankar of NHTSA and for their valuable insights and discussions on the subject.

#### REFERENCES

- [1] NHTSA. 2006. "Traffic Safety Facts 2005". DOT HS 810 631.
- [2] Hurt, H. H., Jr., Ouellet, J. V., Thom D. R. 1981. "Motorcycle Accident Cause Factors and Identification of Countermeasures". Final Report. DOT-HS-F-01160.
- [3] NHTSA. 2005. "National Automotive Sampling System (NASS) General Estimates System (GES): Analytical User's Manual 1988-2004".
- [4] Motorcycle Industry Council (MIC). 2005. "Statistical Annual 2005".
- [5] FHWA. 1980-2005. Highway Statistics Publications.
- [6] NTSB. 2006. "Public Forum on Motorcycle Safety". National Transportation Safety Board. [http://www.nts.gov/Events/symp\\_motorcycle\\_safety/symp\\_motorcycle\\_safety.htm](http://www.nts.gov/Events/symp_motorcycle_safety/symp_motorcycle_safety.htm)
- [7] Turner, P. A., Haegelin, C. 2005. "Motorcycle Helmet Use and Trends before and after Florida's 2000 Helmet Law Change". Transportation Research Board; Transportation Research Record Paper 05-1432
- [8] Savolainen, P., Mannering, F. 2007. "Probabilistic Models of Motorcyclists' Injury Severities in Single- and Multi- Vehicle Crashes". Accident Analysis and Prevention.
- [9] Wulf, G., Hancock, P., Rahimi, M., 1989. "Motorcycle conspicuity and evaluation and synthesis of influential factors". Journal of Safety Research.
- [10] Susan Wells, Bernadette Mullin, Robyn Norton, John Langley, Jennie Connor, Roy Lay-Yee, Rod Jackson. 2004. "Motorcycle rider conspicuity and crash related injury: case-control study". BMJ, doi:10.1136/bmj.37984.574757.EE.
- [11] NHTSA. 2006. "Traffic Safety Facts: Motorcycles". DOT HS 810 620.
- [12] ACEM (Association des Constructeurs Europeens de Motorcycles). 2004. "Motorcycle Accidents In-Depth Study (MAIDS)".
- [13] ITARDA (Institute of Traffic Research and Data Analysis). 2005. "Japan Traffic Accident Statistics Annual Report."
- [14] Ouellet, J. V., Hurt, H. H., Jr., Thom, D. R. 1987. "Alcohol Involvement in Motorcycle Accidents". SAE No. 870602.
- [15] Kasantikul, V., Ouellet, J.V., Smith T.A., Sirathranont J., Panichabhongse, V. 2005. "The Role of Alcohol in Thailand Motorcycle Crashes". Accident Analysis & Prevention; 7, (2): 357-366.
- [16] Kim, K., Kim, S., Yamashita E. 2000. "An Analysis of Alcohol Impaired Motorcycle Crashes in Hawaii, 1986-1995". Transportation Research Board, Transportation Research Record No. 1734, 77-85.
- [17] Ouellet, J.V., Kasantikul, V. "Motorcycle Helmet Effect on a Per-Crash Basis in Thailand and the United States". 2006. Traffic Injury Prevention.
- [18] NHTSA. 2006. "Traffic fatalities by State and Percent Change from 2004". DOT HS 810628.
- [19] Kraus, J.F., Peek, C., McArthur, D. L., Williams, A. 1994. "The effect of the 1992 California Motorcycle Helmet Use Law on Motorcycle Crash Fatalities and Injuries". JAMA; 272 (19) 1506-1511.
- [20] Peek-Asa C., Kraus, J. F. 1997. "Estimates of Injury Impairment after Acute Traumatic Injury in Motorcycle Crashes before and after Passage of a Mandatory Helmet Use Law". Annals of Emergency Medicine; 29(5): 630-636.
- [21] Preusser, D. F., Hedlund, J. A., Ulmer, R.G. 2000. "Evaluation of Helmet Law Repeal in Arkansas & Texas". NHTSA. DOT HS 809 131.
- [22] Auman, K.M., Kufera J. A., Ballesteros, M.F., Smialek, J. E., Dischinger, P. C. 2002. "Autopsy Study of Motorcyclist Fatalities: The Effect of the 1992 Maryland Motorcycle Helmet Use Law". American Journal of Public Health, 2002; 92(8) 1352-1355.
- [23] Peek-Asa, C., McArthur, D.L., Kraus, J.F. 1999. "The prevalence of non-standard helmet use and head injuries among motorcycle riders". Accident Analysis Prevention. 31: 229-233.
- [24] Polk. 2006. Automotive National Motorcycle Vehicle Population Data: 2000-2005.
- [25] Kasantikul, V. 2002. "Motorcycle Accident Cause Factors and Identification of Counter-measures in Thailand": Volume I: Bangkok, KP Printing, Bangkok (Available from the authors as a PDF file.)